

Chimney Fires: Causes, Effects & Evaluation

Prepared by

Chimney Safety Institute of America

Chimney Fire Education and Research Task Force

Jerry E. Isenhour, Sr., Chairman

James P. Brewer

Ashley Eldridge

P.C. Luter III

and

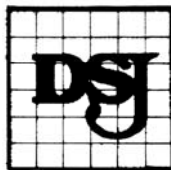

Technical Services

David S Johnston

Chimney Safety Institute of America

2155 Commercial Drive

Plainfield, Indiana 46168

(317) 837-5362

Fax: (317) 837-5365

www.csia.org

Chimney Fires: Causes, Effects & Evaluation

©Copyright 2007 by Chimney Safety Institute of America

First Printing - 1992

Second Printing (with corrections) - 1992

Third Printing – 2003

Fourth Printing (with corrections) – 2007

All rights reserved. No part of this book may be reproduced without permission in writing from the publisher, except by a reviewer who may quote brief passages or reproduce illustrations in a review with appropriate credit; nor may any part of this book be reproduced, stored in a retrieval system, or transmitted in any form or by any means-electronic, photocopying, recording, or other-without permission in writing from the publisher.

Printed in the United States of America

This publication is designed to provide accurate and authoritative information in regard to the subject matter covered. It is sold with the understanding that the publisher is not engaged in rendering legal or other professional services. If legal advice or other expert assistance is required, the services of a competent professional should be sought.

ABSTRACT-- CHIMNEY FIRES: CAUSES, EFFECTS & EVALUATION

CHAPTER 1 Identifies and defines relevant terminology – heating system, venting system, flue gases, chimney, vent. Types of chimneys – metal, factory-built, and masonry – are identified and their construction discussed. Chimney performance requirements are listed. The purpose and function of flue lining are detailed. Flue lining systems are described, and alternatives are identified.

CHAPTER 2 Chimney Fire is defined and sources and causes are identified. Fuels and other combustibles – creosote, wood, soot – are identified and discussed. Thermal characteristics of chimney fires and the evidence that a chimney fire has occurred are presented. The potential damage to the chimney, to other objects, and to the house are detailed.

CHAPTER 3 Thermal damage to clay flue lining is described. Thermal stress theory and concepts are identified, including stress resistance, steady state conditions, transient conditions, and thermal shock. Also included are discussions of how the shape of the flue influences damage caused by chimney fires.

CHAPTER 4 A guide to the evaluation of chimney fire damage, emphasizing the importance of searching for and verifying evidence of causes and effects of chimney fires. Also, evaluation of other possible causes of chimney damage —lightning, thermal expansion, material fatigue, moisture, weathering, freeze/thaw damage, flue gases, condensation, rotational and differential settlement.

CHAPTER 5 Application of insurance to chimney fire damage. Identification of available homeowners' policies and their provisions and coverage. Coverage for damage under the fire peril is detailed. Procedures and criteria for recognition and evaluation of a valid chimney fire claim are discussed, as are arguments not relevant to proper consideration of insurance coverage.

TABLE OF CONTENTS

Introduction	i
Acknowledgments	ii
Chapter 1: Masonry Chimneys and Chimney Lining	1-1
1.0 Introduction.....	1-1
1.1 Chimney Concepts.....	1-1
1.2 Masonry Chimneys.....	1-2
1.2.1 Chimney Performance Considerations	1-3
Venting Performance of Chimneys.....	1-3
Thermal Performance of Chimneys	1-4
1.2.2 General Chimney Construction and Components.....	1-6
Components	1-7
Foundation/Footing; Chimney Wall; Flue Lining; Chimney Crown; Cleanout; Thimble; Firestopping	
Construction Consideration.....	1-8
Termination Height; Multiple Flues; Chimney Offsets and Corbelling; Interface with Fireplace	
1.3 Flue Lining.....	1-10
1.3.1 Purpose and Function of Flue Lining.....	1-10
1.3.2 Flue Lining Systems	1-13
Clay Flue Lining	1-13
Shapes, Sizes and Joints; Manufacturing; Performance Characteristics; Installation of Clay Flue Lining	
Alternative Lining Systems.....	1-20
Stainless Steel Lining Systems; Cast-In-Place Liners; Modular Masonry Systems	
Chapter 2: Behavior and Effects of Chimney Fires	2-1
2.0 Introduction	2-1
2.1 Definition of “Chimney Fire”	2-1
2.2 Creosote	2-2
2.2.1 Origins of Creosote: Wood Combustion.....	2-3
2.2.2 Methods of Creosote Accumulation	2-4
2.2.3 Creosote Transformation.....	2-5
2.3 Chimney Fires: General Description	2-7
2.3.1 Ignition of Creosote	2-7
Fuel	2-8
Temperature	2-9
Availability of Oxygen.....	2-10
2.3.2 “Free-Burning” Chimney Fires	2-11

External signs.....	2-11
Progression.....	2-12
2.3.3 “Slow” Chimney Fire.....	2-15
2.3.4 Duration and Extinguishment	2-17
2.4 Thermal Characteristics of Chimney Fires	2-18
2.4.1 Normal Operation	2-18
2.4.2 Overfire Operation	2-20
2.4.3 Chimney Fire Conditions.....	2-21
2.5 Signs and Effects of Chimney Fire Occurrence	2-25
2.5.1 Creosote Condition	2-25
2.5.2 Effects on Chimney and Other Objects.....	2-29
Damage of Flue Lining	2-29
Damage to Chimney Wall.....	2-31
Damage to Other Objects.....	2-32
Damage to House.....	2-32
Chapter 3: Mechanisms of Thermal Damage to Clay Flue Lining	3-2
3.0 Introduction	3-2
3.1 Thermal Stress Concepts.....	3-2
3.1.1 Thermal Stress Resistance	3-3
3.1.2 Steady State Conditions	3-4
3.1.3 Transient Conditions	3-5
3.1.4 Thermal Shock Conditions.....	3-6
3.2 Shape Effects: Hollow Cylinders.....	3-7
3.2.1 Temperature Gradient Through Cylinder Wall.....	3-7
3.2.2 Directions of Thermal Expansion	3-7
3.2.3 Direction of Cracks	3-8
3.2.4 Opening and Closing of Cracks	3-9
3.2.5 Secondary Cracks.....	3-9
3.3 Discussion of Application to Flue Liners	3-10
3.3.1 Severity of Conditions Necessary for Damage	3-10
3.3.2 Characteristics of Thermal Shock Damage.....	3-13
Chapter 4: Field Evaluation of Chimney Fire Damage.....	4-1
4.0 Introduction.....	4-1
4.1 General Principles of Evaluation & Decision Making	4-1
4.2 Developing Evidence of Chimney Fire Damage.....	4-3
4.2.1 Occurrence of Fire	4-4
Direct Evidence.....	4-4
Physical Evidence	4-4
4.2.2 Characteristic Damage from Chimney Fires	4-7
Damage to the Flue Liner.....	4-7
Other Damage to Chimney	4-9

	Damage to the Building	4-9
4.3	Evaluation of Other Possible Causes of Chimney Damage	4-10
	4.3.1 Damage From Thermal Causes	4-11
	Non-Creosote Fire Thermal Shock	4-11
	Lightning	4-11
	Differential Thermal Expansion	4-11
	Thermal Fatigue Cracking	4-13
	4.3.2 Moisture-Related Damage; Weathering; Freeze/Thaw Damage	4-14
	Condensation of Flue Gases	4-15
	Differential Moisture Expansion of Shrinkage	4-15
	4.3.3 Settlement	4-16
	Rotational Settlement	4-16
	Differential Settlement	1-17
	4.3.4 Miscellaneous Movements of Chimney	4-18
	Chapter 5: Application of Insurance to Chimney Fire Damage	5-2
5.0	Introduction	5-2
5.1	Homeowners Policies	5-2
	5.1.1 Homeowners Forms	5-4
	5.1.2 Policy Provisions	5-5
	5.1.3 Perils Insured Against	5-5
	5.1.4 Exclusions	5-6
	5.1.5 Conditions	5-7
5.2	Coverage Under Fire Peril	5-8
5.3	Application of Fire Peril to Chimney Fire Damage	5-10
	5.3.1 Qualification of Claim	5-11
	Evidence of Chimney Fire Occurrence	5-12
	Identification of Damage	5-12
	Verifying Cause of Damage	5-12
	Rules for Evaluation of Chimney Fire Claims	5-13
	5.3.2 Irrelevant Considerations	5-14
	Safety: Prior or Consequent to a Fire	5-14
	Degree of Damage as Determinant	5-15
	Prior Damage	5-16
	Severity of Fire as Measure of Peril	5-16
	Latent Defect; Faulty Installation	5-17
	Lack of Maintenance by the Insured	5-17

INTRODUCTION

As the author of this publication observes in the introduction to Chapter 1, “Chimneys are far from the passive black holes most people assume them to be. They perform several vital functions, and their simple appearance belies a complex of interrelated construction and performance requirements.” If the layperson is reminded of “Mary Poppins” each time he or she sees smoke rising from a chimney, the tradesman who builds or repairs or sweeps a chimney thinks immediately of what is going on in that chimney. Is it operating safely and efficiently? How long has it been since it was inspected and swept? Do the operators of the heating system of which it is a part know how to use it and treat it? Is the structure, which the chimney serves, properly insured against a damaging malfunction?

There is nothing much more frightening than a chimney fire. Chimney fires have occurred as long as there have been chimneys, and a substantial amount of folklore and hearsay wisdom has grown up around them. Edinburgh, Scotland, has long been known by its residents and Scots in general as “Auld Reekie.” The name refers to the smoke with which the city used to reek when the basic fuel in Scotland was peat, or wood, or coal. Edinburghians still sing the song, “Tam Bain’s Lum” on occasion. A “lum” in Lowland Scottish is a “chimney.” Tam Bain’s “Lum”, according to the song, had a life of its own and played many a trick on its owner. The modern chimney, when disregarded and poorly maintained, also presents the potential for playing tricks on its owner . . . dangerous, damaging and sometimes life-threatening tricks.

This publication has been written and published to provide professional tradesmen, fire and public officials and insurance industry representatives with a general but comprehensive reference on the origin, behavior, and effects of chimney fires. With the renewed use of alternative heating fuels such as wood and coal in the last decades, the incidence of chimney-related fires has also risen. The body of knowledge which exists on the subject has also increased dramatically because of the increased observation of individuals involved with the design, construction, maintenance, evaluation, and repair of chimneys and venting systems. Safety authorities have also turned their attention to this subject, and this attention has

stimulated research into the causes and effects of chimney fires.

A substantial body of knowledge has existed for some time, but it has never been assembled, reviewed, and analyzed. There has been no common basis for understanding chimney fires, and some disagreement has arisen in the field about the causes, characteristics, and mechanisms of damage of these fires. It is the hope of the Chimney Safety Institute of America (CSIA) that this report, which draws from historical references, anecdotal accounts, laboratory studies, and published literature, will help clarify many of the issues surrounding chimney fires and supply a common ground for practical evaluation and decision-making. It is also hoped that this report will stimulate discussion and continuing laboratory research into this complex subject. It is the long-range goal of the CSIA that benefits will accrue in the form of better products for chimney and venting systems and an improvement in the safety of those who use or may be affected by chimneys.

It is further hoped that this paper will be used as a reference by individuals performing cause and effect evaluations of chimneys and venting systems. This report should furnish a reliable source for forming credible opinions based on documented research rather than on conjecture.

The Chimney Safety Institute of America is a non-profit tax-exempt educational institution founded in 1983. Its primary mission is aimed at improving safety standards and the operating efficiency of chimney and venting systems through the education of individuals and organizations involved in the design, construction, evaluation, maintenance, and repair of chimney and venting systems. An element of The CSIA’s educational effort is the nationally-recognized Certified Chimney Sweep® program, a program that educates and tests chimney service company owners and employees on the codes, clearances, standards, and practices of the trade. CSIA also administers the C-DET program. In addition, CSIA provides continuing public education programs and programs designed to enhance the knowledge and understanding of individuals in government, fire service, the insurance industry, and other related groups and organizations.

ACKNOWLEDGMENTS

This report attempts to bring together a broad spectrum of chimney fire knowledge, from a wide variety of sources, into a single resource. This effort would not have been possible without the contributions of a great many individuals and organizations. It is impossible to acknowledge and thank every individual that provided information, assistance and encouragement for this report. However, the Chimney Safety Institute of America would like to acknowledge the following for giving unselfishly of their time and experience and for their significant impact on the completeness and accuracy of this report through their contributions of information, valuable suggestions and technical assistance.

Arlene Bamhart,
Librarian
Charles Morgan Technical Library
National Fire Protection Association
Quincy, Massachusetts

Floyd Herrick
Herrick-Laylor Engineering, PC
Rochester, New York

Nora H. Jason
Project Leader
Fire Research Information Service
National Institute of Standards and Technology
Gaithersburg, Maryland

Michael K. McCracken, CPCU
Assistant Editor
The Fire, Casualty & Surety Bulletins
Cincinnati, Ohio

Dr. Wayne Palmour
Professor of Materials Science & Engineering
North Carolina State University
Raleigh, North Carolina

Richard D. Peacock
Fire Hazard Analysis
Center for Fire Research
National Institute of Standards and Technology
Gaithersburg, Maryland

Robert Rucker
CMS Industries
Williamson, New York

Thomas E. Shreves
Librarian
American Ceramic Society
Columbus, Ohio

Jerry G. Stockhridge
Vice President Operations
Wiss, Janney, Elstner Associates, Inc.
Northbrook, Illinois

Richard L. Stone, Consultant
Director of Research and Engineering (ret.)
Metalbestos Systems
Bodega Bay, California

Dr. J. D. Walton
Georgia Tech University (ret.)
Atlanta, Georgia

*The individuals acknowledged here are not responsible for any errors that may be present in this document.
Conclusions drawn and actions recommended are solely those of the authors unless otherwise indicated.*

CHAPTER 1:

Masonry Chimneys and Chimney Linings

1.0 INTRODUCTION

This report is about chimney fires and the damage they cause. It discusses the structure in which such fires occur and which is most frequently damaged by them. A detailed explanation of the goals of chimney construction and the characteristics of the materials most commonly used should help the reader better appreciate the abnormality of chimney fires and the seriousness of their consequences.

Because of the wide variety of chimney designs and construction details, this chapter puts an emphasis on the purpose or function of chimneys and their various components. *This reflects the general trend, growing stronger in the last few years, to move away from rigid specifications toward greater recognition of performance as the measure of acceptable design or construction.* While certain specifications and minimum requirements can probably not be entirely eliminated, the current effort in codes and building standards is to provide flexibility in the way chimneys meet agreed-upon goals.

This is a useful principle for the understanding and evaluation of existing chimneys as well. Instead of treating a chimney as a collection of specified materials, assembled according to habit or recipe, it is more productive to understand it as a system of interrelated components, each of which plays a role in the overall success of the system. By concentrating on the purpose and characteristics of those components, it is possible to better appraise *the ability of a chimney to perform its intended functions.* It should also help underscore the importance of proper performance-oriented construction and the effect of abuse or failure of some components on the integrity of the heating and venting system as a whole.

1.1 CHIMNEY CONCEPTS

The chimney is one of the most taken-for-granted parts of a building, yet is one of the more essential. Chimneys tend to receive neither the attention nor the concern usually accorded other household service systems, such as the electrical, plumbing, and vented heating appliances. The fact

that chimneys tend to do their job reasonably well, even when abused or neglected, contributes to this atmosphere of indifference. Chimneys are far from the passive black holes most people assume them to be. They perform several vital functions, and their simple appearance belies a complex of interrelated construction and performance requirements.

Before a discussion of chimneys is undertaken, a general discussion of some of the concepts that will be used through this report is in order. *A heating system is the entire system of interrelated components which contribute to the production and delivery of heat to the building.* A fuel burning heating system will, in general, consist of an appliance, a distribution system, and a venting system. A venting system is a series of open conduits extending from the appliance flue outlet to the outside atmosphere for the purpose of removing flue gases. Flue gases contain the products of combustion from a fuel burning appliance plus any excess air which bypasses the combustion process. The products of combustion, and thus the flue gases, can include actual gases, condensable liquids, and tiny liquid droplets or solid particles borne by the general flue gas flow.

Venting systems generally consist of a chimney or vent, plus a chimney or vent connector. The purpose of the connector is to convey the products of combustion from the appliance to the vent or chimney. A chimney is a structure designed and manufactured or constructed to form and enclose one or more vertical (or nearly so) passageways through which products of combustion pass to the outside atmosphere. Such passageways are known as flues. A chimney is designed to properly vent any appliance within a particular class or range of service, while a vent is a manufactured product intended only to serve a specific type of appliance under narrowly defined conditions. Chimneys can be characterized as a "general purpose" venting systems while vents have a limited or dedicated purpose.

Chimneys can be of three types: metal, factory-built, and masonry. Metal and factory built chimneys are not similar types. They are distinct entities. A metal chimney is a generic single-wall

smokestack made of relatively thick metal. Although metal chimneys may be used in some commercial and industrial occupancies, they cannot be used for venting appliances in one- and two-family dwellings. Factory-built chimneys are often made of metal, but they are constructed of multiple walls, and they are designed for general residential use. Factory-built chimneys are listed systems. They have been evaluated by a recognized agency and found suitable for their application, and they must be assembled according to specific instructions. Masonry chimneys, on the other hand, are field-constructed assemblies of generic masonry materials such as brick, concrete, or stone.

There are some modular factory-built masonry units available today. The fireplace and chimney are listed as a system to UL 127. The modular masonry chimney may be used independently and would be listed to UL 103. The chimney may be installed with zero clearance to combustibles, something conventional site-built masonry cannot offer.

Chimneys are classified by most codes and standards into several categories based on the intended severity of service. Residential type chimneys are those intended for continuous exposure to flue gases not in excess of 1000°F measured at the appliance flue gas outlet, under normal operating conditions. Residential type appliances, in turn, are those which have been tested and shown to not produce continuous outlet temperatures greater than 1000°F. In other words, all residential type chimneys are eligible to serve any residential type appliance with only a few exceptions.¹

Building codes and other standards draw a firm distinction between a chimney and the appliance(s) connected to it. Where appliances are designed to contain and support the combustion process and to utilize the heat released, the venting system is designed only for the removal of the flue gases which inevitably result from combustion. Even masonry fireplaces in which the "appliance" is incorporated into the overall masonry structure are clearly divided into distinct "combustion chamber" and "chimney" assemblies. *It is a major-assumption in chimney design that the venting system will host only the (non-burning) products of combustion during normal operation, and that combustion itself will be limited to the appliance.*

It is recognized that incidents of abnormal operation will inevitably occur. Chimney design must allow for a certain level of abuse, and this allowance is reflected in codes and standards criteria for chimney construction. Chimneys must be, in effect, "overbuilt" for the conditions likely during normal operation in order to withstand a certain degree of improper operation. However, *fixing the degree or severity of abuse to be allowed for is difficult, if not impossible. No "maximum" level of abuse can be anticipated — only degrees of risk associated with different potential occurrences.* Chimney design is based on judgments about the likelihood and consequences of various abnormal events. Inevitably, there will be cases that exceed those expectations.

In designing for abnormal circumstances, the focus shifts increasingly from protection of the chimney itself to protection of the building and its occupants. *The emphasis is on limiting the consequences of a damaging or tragic event.* If abusive conditions are unavoidable, the potential for damage or deterioration of the chimney is increased, but under the same conditions the chimney should still prevent or minimize further property damage or danger to people. Obviously, there are limits even to this philosophy. There are circumstances that exceed even the chimney's ability to provide protection, but the concept of multiple layers of containment is evident in many of the design and construction principles discussed below.

1.2 MASONRY CHIMNEYS

This report is concerned primarily with the behavior and effects of chimney fires in masonry chimneys. The rest of this chapter, and for the most part the rest of this report, will therefore be limited to a discussion of masonry chimneys. Many of the concepts and phenomena discussed do have a similar application in other types of venting systems, particularly factory-built chimneys. While a discussion of the broad range of venting systems would be interesting, such is beyond the scope of this report.

This section introduces the fundamental principles of performance and safety under which all chimneys operate and the way these principles influence the design considerations for masonry chimneys. The specific components and assemblies commonly incorporated into masonry chimneys are then outlined, with emphasis on the

function they perform in contributing to a successful chimney structure.

1.2.1 CHIMNEY PERFORMANCE CONSIDERATIONS

Chimneys have several purposes: 1) to fully exhaust the combustion products generated by a connected fuel-burning appliance to the outside atmosphere; 2) to draw primary and excess combustion air into the appliance²; and 3) to protect the building and its occupants from the adverse effects of the combustion products, including heat, gases, and moisture. For most appliances, these functions are firmly interlocked. If one fails or is inadequate, the others will suffer or eventually fail as well. In effect, the chimney is the active part of a fuel-burning system. *The appliance supplies or holds the fuel, but without an active and properly functioning chimney the appliance will be unable to operate properly.*

Venting Performance Of Chimneys

Chimneys do not gain the ability to contain and conduct the products of combustion and ensure a supply of combustion air to the appliance by accident. *Chimneys operate according to an interrelated set of fundamental principles which determine the success —or failure — of any particular design.* One could call them the laws of physics.

The force which drives the venting functions of a chimney is draft — the pressure difference between ambient air and the warmer less dense flue gases within the chimney. The lighter flue gases are buoyant. They tend to rise and be displaced by the heavier ambient air. *The movement of gases which results is the flue gas flow: the volume or weight of gases which pass through a venting system in a given period of time. Air is pulled into the appliance in exact proportion to the amount of flue gases which are exhausted.* In other words, draft is the force which causes flow; the outward flow of waste gases necessitates their replacement by the fresh air required to support continued combustion.

In short, chimney design involves considerations of both draft and flow capacity that have an interrelated and dynamic relationship. There is no single “correct” chimney design. *Some applications demand more emphasis on draft while others sacrifice maximum draft in favor of more optimum flow capacity.* Although most

chimneys are specified empirically according to some fairly solid generalizations, there is a growing realization that chimneys need to be designed for the needs and characteristics of the appliances to be connected. *As modern appliances become more sophisticated, the venting conditions necessary for proper operation become more exacting.*

The results of inattention to fundamental design and construction requirements are consequently becoming more apparent. They include, in their most benign form, unsatisfactory appliance operation such as poor efficiency, sluggish or inconsistent startup, and more frequent need for service. More serious, from a safety standpoint, is the increased risk of flow reversal or spillage of combustion products. Both poor design and construction also influence the rapidity of deterioration of the chimney itself which, in turn, can adversely affect both appliance performance and safety.

In order to fully perform its function of containing the products of combustion, a chimney must not only successfully remove these products from the appliance and exhaust them from the top but also prevent their leakage as they pass through the system. *In other words, a chimney must be effectively moisture and gas-tight. The first "line of defense" in ensuring containment of gases is the fact that chimneys operate under negative pressure; that is, the pressure of gases inside the chimney is less than the surrounding air.* Given the opportunity, air will flow into the chimney, and flue gases will not flow out. Thus, during normal operation, even a chimney with a hole in it would not leak gases if there are no outside influences that would compete with these pressure differences.

Abnormal operating conditions must be anticipated, including the possibility of episodes of positive pressure within the chimney. Furthermore, any moisture resulting from entry of rainwater or condensation of flue gases must not be allowed to leak. The masonry materials most commonly used to form chimney walls, brick, concrete block, and stone, together with the mortar used to join them, are relatively porous and cannot be expected to fully contain the combustion products by themselves. In addition, *they are not immune to the corrosive and erosive effects of continual exposure to these elements and will deteriorate relatively rapidly under*

typical conditions. Therefore, modern chimney design requires a *flue lining, the primary purpose of which is to contain the combustion products and prevent their contact with the chimney wall.* The design, construction, and performance requirements for flue linings in order to achieve this goal will be discussed in a later section.

Thermal Performance Of Chimneys

In order to produce draft, a chimney must contain hot flue gases. Both to maintain the temperature of those gases and to prevent excessive heat from reaching the outside of the chimney and its surroundings, a chimney must be designed and constructed to minimize heat loss. Even a single wall metal pipe can contain a column of warm gases and thus develop at least some draft and flue gas flow, but such a venting system would serve as an unsatisfactory chimney. The draft and flow developed would be unreliable and sluggish, and its ability to protect the structure and occupants from heat and spilled flue gases would be suspect.

Residential masonry chimneys are defined by their ability to operate satisfactorily and protect the building while under exposure to continuous flue gas temperatures up to 1000°F. In practice, the typical operating temperatures of residential appliances are considerably less than this maximum. *Listed residential gas appliances must not exceed 480°F and generally operate in the 300 degree range. Oil burning appliances typically operate a bit hotter but still below 500°F.* Even residential wood and coal burners which are subject to operator variables do not usually approach the 1000°F limit and very rarely do so, on a continuous basis.

Chimney design, however, must anticipate both appliance malfunction and operator error. The performance requirements for chimneys and design specifications found in codes reflect the need to provide protection against hotter-than-normal continuous operation and relatively brief episodes of even higher temperatures. As anticipated temperatures get higher, the emphasis shifts from protection of the chimney to protection of its surroundings.

The protection of adjacent combustible material must allow for the fact that wood and other combustible materials suffer from decreased resistance to ignition after exposure to continual heating at even moderate temperatures. Wood itself has a relatively high ignition temperature —

ranging from 400 to 480°F for most species. When exposed to sudden heating, fresh wood must be raised at least to this temperature before a self-sustaining combustion reaction will begin to take place.

When wood is exposed to heat over a period of time, however, it undergoes a gradual change in its molecular structure through a process called pyrolysis. The complex organic molecules of which wood is composed are slowly broken apart, and much of the original weight and structural integrity of the wood is lost. As this process continues, the material left behind is charcoal, which is also known by the more ominous sounding and technically correct term pyrophoric carbon. Pyrophoric carbon is different from wood and has different properties. First, it has a significantly lower ignition temperature than that of the original wood. *Various studies have fixed this temperature at 200 to 250°F, and there are suggestions that the figure could be even lower.* Secondly, pyrophoric carbon is known to adsorb oxygen from the air into its porous structure. The adsorbed oxygen can combine with the carbon with sufficient rapidity to generate considerable heat. In other words, not only will *pyrophoric carbon ignite at a lower temperature, but when exposed to air it can generate some of the heat of ignition itself.*³

There are numerous documented cases of ignition of wood near low-pressure steam pipes which cannot get hotter than about 250°F. Typically, these occur in a hidden area where air cannot circulate freely to dissipate heat. Invariably, the fire starts after months or even years of exposure, and there is evidence that the intermittent nature of the heating pattern contributes to the likelihood of ignition. Fires related to the long-term pyrolysis of wood usually begin with slight glowing of the exposed charcoal. This incipient combustion releases heat which accelerates the ignition of adjacent material. Finally, when sufficient heat has built up or when a fresh supply of air becomes available, flaming begins and the fire spreads rapidly.

Ignition of wood surrounding chimneys is also well documented. While some of these fires may be due to a sudden rise in temperature into the range of the ignition temperature of fresh wood, the majority are caused by the same scenario recognized for steam pipes: long term intermittent exposure to moderate heating. Concealed areas

such as floor/ceiling assemblies and wall penetrations are particularly vulnerable, and the on-off pattern of heating from chimneys probably contributes to the problem. Wood exposed under these circumstances is converted to pyrophoric carbon and is "primed and ready" to burn. Often an unusual incident such as accidental overfiring or, as we shall see, a chimney fire provides the occasion for ignition. *The temperature produced by the chimney need not become extremely high. A rise into the 200°F range, together with the self-heating properties of the carbon, may be sufficient to initiate the combustion process.*

It is generally agreed that exposure to temperatures ranging from 200 to 250°F on a long term or intermittent basis can result in the ignition of wood. Therefore, the engineering and test criteria for *chimney design require that wood exposed to heating from a chimney not rise in temperature more than 90°F over ambient temperature, i.e., about 170°F.* Some test standards allow brief periods of higher temperature rise during short-term abnormal operation tests, but the conservative approach to temperature limitation is paramount.

The ability of a chimney to protect the building and occupants from the heat of flue gases overlaps with its ability to contain the other products of combustion, i.e., gases and moisture. Many of the design and construction considerations for proper venting are also critical for thermal performance. A chimney must be designed and constructed to be both gas and moisture-tight, but no chimney can be literally "heat-tight" in the sense that no loss of heat is allowed. Chimney features which prevent leakage of gases and moisture also contribute to the retention of heat and minimize temperature rise on the chimney exterior.

The most important design and construction features for limiting excessive temperature rise on adjacent combustibles are:

- Presence of proper flue lining between the hot gases and chimney wall;
- Materials and thickness of the chimney wall; and
- Clearance of combustible material from the chimney exterior.

In addition to its function of containing the gaseous and liquid products of combustion, the flue liner is a key element in reducing the transfer of heat from inside the chimney structure. Both

laboratory studies and field experience have shown that the presence of an intact liner dramatically reduces temperatures on the chimney exterior and thus the risk of fire during both normal and abnormal operation. These studies together with the design and construction details of linings will be discussed more fully in a later section.

The chimney wall serves both as the primary structural element of a chimney and as a thermal buffer. The better the insulating value of the wall, the lower the temperature on the exterior surface of the chimney. However, masonry chimney walls are not remarkably good insulators. *A single wythe brick wall, by itself, has an R-value of only about .75 hft²°F/BTU — equivalent to about one-fourth inch of fiberglass insulation.* Masonry materials do have a characteristic that partially offsets their poor insulating ability: a *high thermal inertia.* Masonry materials can absorb a large amount of heat while showing a relatively small temperature rise. Combined with their large mass, this means that *masonry chimneys can tolerate transient rises in flue gas temperatures without a resulting dramatic increase in exterior temperature.*

Thermal inertia is most effective at delaying the transfer of heat, not preventing it altogether. Given an exposure to high temperatures of sufficient duration, the masonry will eventually heat up considerably. Therefore, the insulating value given by the presence of the liner as well as the overall thickness of the wall is still of considerable importance in reducing exterior temperatures. *Thermal inertia by itself cannot prevent the development of unsafe temperatures.*

Despite the insulating value and thermal inertia provided by masonry construction, all chimneys require a certain air space clearance from combustible material. Chimneys with any part of the chimney wall within the building must have a two-inch clearance. Those located entirely outside the building require a one-inch clearance. The existence of an air space is vital. *The effectiveness of clearance depends on the ability of air to both insulate the space and move heat away to another area through convection.* Filling of the space, even with insulating materials, may actually increase the temperature to which combustibles are exposed.

In order for a chimney to perform its essential functions of removing flue gases, providing

combustion air, and protecting its surroundings, a number of design factors must be included and balanced. No single characteristic makes a chimney "work." A number of different and interrelated considerations work together to produce a successful chimney. These considerations include issues of sizing and other dimensions, of choice of materials and components, and of construction technique. With this background in the performance requirements for masonry chimneys, a discussion of the materials, components, and construction usually used to achieve these goals can follow.

1.2.2 GENERAL CHIMNEY CONSTRUCTION AND COMPONENTS

Chimneys can be and in some cases must be designed from scratch. With the increasingly precise demands that modern appliances place on chimney performance, the need for carefully matching venting system characteristics to the

needs of the appliance is paramount. *It is becoming more common to find that "customized" venting systems are required or that existing chimneys must be modified in some way to accommodate a new appliance.*

Historically, the performance principles of chimney design have been expressed in a fairly limited set of standard components and construction techniques. Because older appliances were more forgiving of less than ideal venting conditions, a relatively small number of general designs have been able to serve the majority of appliances. The general rules for chimney construction could be set forth in codes and guidebooks and generic materials used in predictable ways. Although this situation is changing, it is a gradual process, and most chimneys still share common components and characteristics which are summarized below, and illustrated in Figure 1-1.

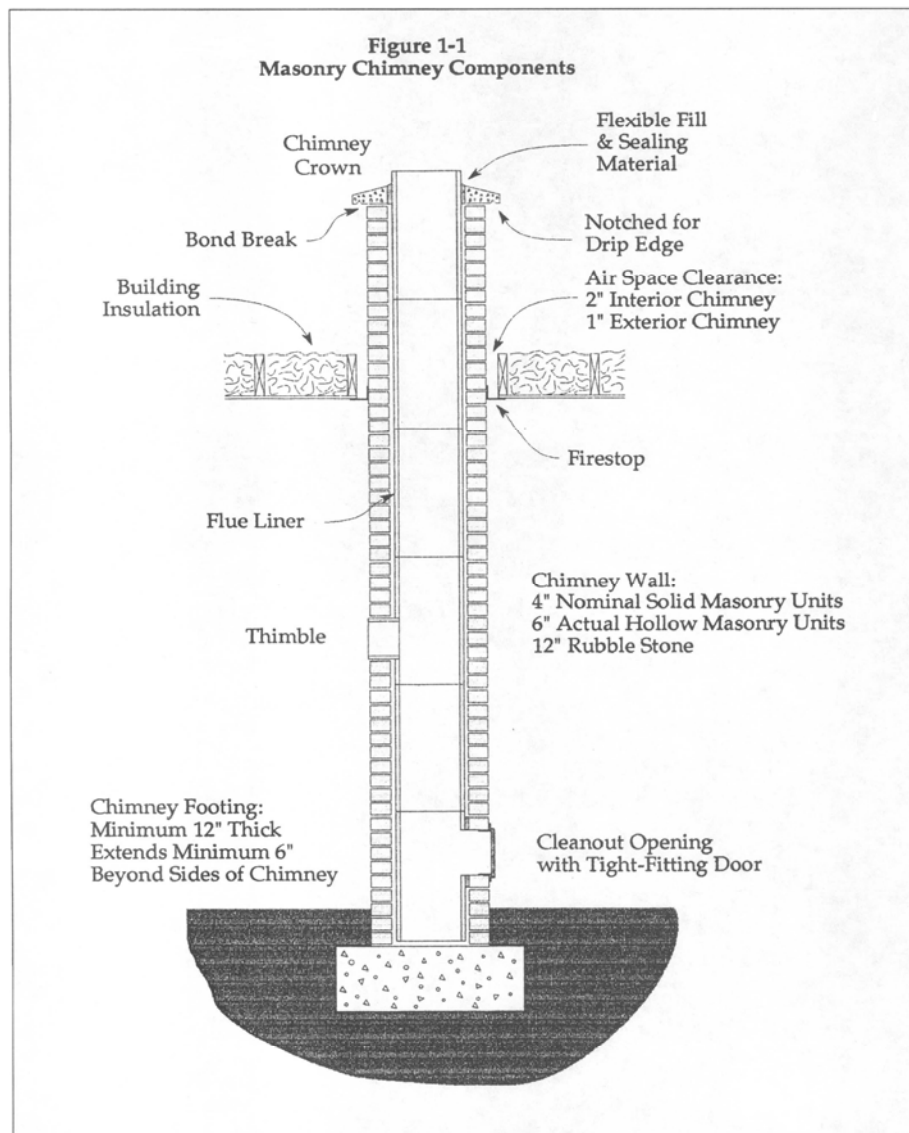

The following components are either found in all chimneys or are common options. Chimneys which are incorporated into the overall structure of a masonry fireplace have essentially the same characteristics, and any pertinent differences are noted. The requirements or specifications noted are, for the most part, common to most building codes and nationally recognized construction standards; however, certain features are either not addressed in all codes or are treated differently. In such cases, the references will generally be to the requirements of NFPA 211⁴ or the recommendations of the Brick Industry Association⁵ which together tend to represent the state-of-the-art standards for masonry chimneys. Even the International Code Council⁶ follows most of the same construction requirements. While this discussion is far short of a complete review of chimney construction, it should provide a general familiarity with the accepted principles of chimney construction.

Foundation/Footing

Because masonry chimneys represent a significant concentrated load, proper support is critical. Ideally, the chimney will be carried on the same foundation as the building structure to provide assured support and to minimize differential movement between the two. *In practice however, most chimneys are placed on a separate footing.*

In general, codes require chimney footings to be a minimum of 12 inches thick and to extend a minimum of six inches beyond all faces of the chimney. The footing must be placed on undisturbed earth below the local frost line. *Most modern codes do not allow a chimney to carry superimposed loads from the building structure, so these rules are adequate for most chimney loads. Where additional loads are involved, the chimney foundation must be designed according to code requirements for structural foundations.*

Chimney Wall

Although the role of the chimney wall in the thermal performance of chimneys was noted above, its primary and more obvious function is to provide the structural shell of the chimney. Masonry chimney walls are generally constructed of brick, concrete block, or stone. Solid masonry units such as bricks must be four inches (nominal) thick. Hollow units such as most forms of concrete blocks may be used, but the wall must be of reinforced construction a

minimum of six inches (nominal) thick and have the cells fully filled with mortar. Concrete "chimney blocks" which form a complete ring around an interior flue space are popular, but they must adhere to the same thickness requirements. *All concrete products must be waterproofed, and all masonry units must be laid with full-depth push-filled head and bed mortar joints.*

Chimneys of cut stone are generally treated as equivalent to those of brick, and the same thickness requirements are applied. Chimney walls of rubble or field stone, however, must have an actual thickness of at least 12 inches to compensate for the inevitable uneven depth of random stone construction.

Flue Lining

Flue lining plays a critical role in containing the products of combustion and minimizing heat transfer to the chimney wall. There are a number of different materials and forms used for this purpose, but by far the most common is vitreous clay flue lining. Clay lining is usually provided in round, oval, square, or rectangular sections two feet long. Sections should be stacked one section ahead of the construction of the chimney wall and joined with special refractory cement to form a continuous smooth-walled conduit from below the appliance inlet to the chimney termination.

Because of the importance of lining and the number of construction details, flue lining in general and clay lining in particular will be addressed in a separate section.

Chimney Crown (Cap, Splay or Wash)

The purpose of the chimney crown is to close off the space between the flue liner and chimney wall, to shed rainwater clear of the chimney, and generally to prevent the entry of moisture. *Despite its importance to the integrity of the chimney, this is one feature that is neither well-addressed in codes nor well-executed in the field.* Failed or inadequate chimney crowns are among the more common causes of chimney deterioration.

Typically, the crown is formed by simply spreading a thin layer of the same mortar used between bricks across the top of the chimney and against the projecting flue liner. Since mortar does not weather well when used as an exposed wash, such crowns deteriorate rapidly, developing

cracks that allow moisture to enter the chimney. They also direct water to the edge of the chimney where it runs directly down the wall and hastens erosion of brick and mortar.

The recommendations of the Brick Industry of America call for crowns to be either of pre-cast or cast-in-place concrete several inches in thickness. The top surface should have a definite slope away from the flue liner, and the edge of the crown should extend at least two and a half inches beyond the face of the chimney to shed water away from the wall. In addition, the crown should not be bonded directly to the flue liner or to the top of the chimney in order to allow for thermal expansion of the liner. Instead, the small space between the crown and lining should be closed with a flexible sealant. The general performance goals of these recommendations have been incorporated into the NFPA 211. Widespread utilization of these techniques would eliminate one of the more common reasons for chimney repairs.

Cleanout

All chimneys need provisions for cleaning regardless of the fuel utilized. Most codes specifically require a cleanout opening to be provided for each flue at least 12 inches below the lowest appliance inlet opening. For fireplaces, the fireplace opening itself is considered to be the access for sweeping. However, the passage-ways through and above the fireplace throat must be specifically designed for accessibility, or else a separate opening to the chimney must be provided. Other than fireplaces, all cleanouts must be equipped with a ferrous metal, stainless steel, pre-cast concrete, or other approved non-combustible doors and frames that can be secured tightly in place.

Thimble

A thimble is the tubular sleeve embedded in the chimney wall designed to receive the end of the chimney connector. Thimbles are not strictly required, but they are the preferred and most common way to provide for attachment of the connector. Thimbles are generally made of the same vitreous clay as flue linings but may also be of metal. In order to be proper and effective, thimbles must extend from the outside of the chimney to the inside face of the flue lining and be cemented in place with the same cement used for liner joints.

Firestopping

Although not part of the chimney per se, firestops are an essential element of chimney construction. Chimneys which pass through any part of the building structure will result in an opening through one or more floor/ceiling assemblies. Because of the requirement for airspace clearance around the chimney, this opening would be a natural conduit for the spread of smoke or fire through the building. *This opening must be closed off to ensure even basic fire protection to the dwelling.*

Firestopping must fully bridge the gap between the chimney and its surroundings but must not fill the space. The material used should be sheet metal not less than 26 gauge, or other noncombustible sheet material not greater than one-half inch thick. Insulation or other bulk material should never be stuffed into the clearance space to provide a firestop. *Gaps should not exceed 1/16th of an inch.*

Construction Considerations

All masonry chimneys are assembled on site using the generic materials discussed above. They are thus adaptable to a wide variety of situations and can be built in any number of configurations to suit the circumstances. Masonry chimneys typically do not come with "installation instructions." They should be built by skilled trades' people following recognized standards of workmanship, many of which are expressed in masonry industry publications. Codes and standards do provide a number of construction parameters which all chimneys are required to meet. Some of the major considerations are summarized below.

Termination Height

All masonry chimneys, regardless of the appliance type or fuel being utilized, must extend at least three feet above the highest point where they penetrate or pass by the building roof. In addition, they must extend at least two feet higher than any part of the structure or adjacent structures within ten feet horizontally. These rules are intended to provide for both fire safety and venting performance. By ensuring that the top of the chimney is reasonably clear of nearby combustibles, the risk of ignition from hot smoke, flames during a chimney fire, or expelled embers is reduced but not eliminated. The termination height also increases the likelihood that the top of

the flue will be clear of turbulence created by wind and pressure zones caused by adjacent structures. *The aerodynamic effects can vary with different structures and localities, so some chimneys need to be even taller to ensure proper performance.*

Multiple Flues

The overall chimney structure can contain more than one flue to serve different appliances. However, the chimney must be designed and constructed so that 1) each flue is isolated from all the others, 2) products of combustion cannot transfer between flues, and 3) the draft pressure in one flue does not affect the others. NFPA 211 and the Brick Industry of America recommendations require that all flues be separated from each other by a full masonry partition a minimum of four inches (nominal) in thickness. If two flues are used to vent a single appliance, such as a fireplace, the separation is not required. Older codes allowed a maximum of two flues to be grouped together without separation so long as the joints between sections of each flue liner are vertically staggered by at least seven inches. Any additional flues must be separated by a masonry wall.

Individual flues may change direction within a chimney. Any such offsets, however, have a negative effect on the flow capacity of the flue and should be used sparingly. The maximum offset from the vertical is 30 degrees, and the offset portion must be supported such that it won't collapse under its own weight. *Joints between offset sections of flue lining must be mitered so that they form a continuous lined passageway and do not reduce the cross-sectional area of the flue.*

Chimney Offsets and Corbelling

With very definite limitations, the entire chimney structure can be offset. This is accomplished by *corbelling*, or progressively offsetting individual courses of masonry units. Each offset layer cannot project more than one-half the individual unit height nor more than one-third the unit thickness, however. *For bricks of typical dimensions this means that the maximum projection for each course is slightly more than one inch.*

The *total* offset resulting from corbelling a chimney is also limited. The centerline of the flue inside the chimney must not fall beyond the centerline of the masonry wall which encloses it.

The maximum offset is half the width of the flue, plus half the width of the chimney wall. This will ensure that the weight of the upper portion is still fully borne by the lower portion. Masonry chimneys may not be re-supported on structural elements of the building. They must be fully self-supporting.

Interface with Fireplace

Although masonry fireplaces are often incorporated into the overall chimney structure, it is most useful and accurate to think of them as an appliance separate from the chimney rather than as a wide spot in the chimney where the fire goes. A fireplace, as a distinct entity, consists of a base assembly which includes the foundation, hearth, and hearth extension and may also include an ash pit; a fire chamber assembly which is designed and equipped to contain fire; and a smoke chamber assembly which forms the transition between the fire chamber and the venting system. *The chimney begins at the top of the smoke chamber and extends from the bottom of the flue to its termination.*

Fireplaces have the same foundation requirements as do chimneys, and their walls must be constructed to transfer the weight of the chimney directly to the foundation. This is particularly critical in the construction of the smoke chamber which is often composed of walls which slope inward from the fireplace to the narrower chimney. Unlike corbelling of chimneys, codes do not directly limit the amount of "racking" of individual units that is allowed to form this slope. A slope beyond 45 degrees from the vertical is likely to be an unstable support for the chimney and is prohibited for the inside surface of the smoke chamber. Unless they are lined with two inches of firebrick, or equivalent, smoke chambers must have walls at least eight inches thick.

The transition from the smoke chamber to the flue must be smooth and tight. Flue liners must be supported around their entire perimeter by the topmost masonry of the smoke chamber. There should be no gaps around the bottom of the liner which could allow smoke to enter the annular space between the liner and chimney wall. By the same token, *masonry must not project into the smoke path at the bottom of the flue by restricting the opening at the bottom.*

1.3 FLUE LINING

The concept of flue lining and its importance to the proper performance of the chimney has already been introduced. The purpose of this section is to more completely explore the role of lining and how materials, construction techniques, and maintenance considerations affect the success of the lining system.

1.3.1 PURPOSE AND FUNCTION OF FLUE LINING

The requirements of various codes and standards regarding flue lining are strikingly similar primarily because they reflect a shared understanding of the function of lining. This purpose is expressed most succinctly in the definition offered by the training manual for the Canadian wood energy technician certification program:

Flue liner means a clay, ceramic, or metal conduit in a chimney intended to contain the combustion products and to protect the chimney shell from heat and corrosion.⁷

The entire chimney system must be designed to both prevent leakage of moisture and gases and to minimize the loss of heat from the flue with a consequent rise in chimney exterior temperature. Flue lining has become accepted as the primary layer of protection for accomplishing these goals. The performance requirements and specifications of nearly all codes and standards reflect the need to provide a continuous gas and moisture-tight insulating lining between the flue gases and the chimney structure.

The concept and recognition of the importance of flue lining is not new. As early as 1909 the Crosby-Fiske *Handbook of Fire Protection* (predecessor of the current NFPA *Fire Protection Handbook*) required "All chimneys to be of brick with joints struck smooth on inside and provided with hard burned flue lining." In 1916, the *Insurance Engineers' Handbook*,⁷ referencing the Building Code of the National Board of Fire Underwriters, set forth several construction requirements for flue lining, including the sealing of joints and full-length extension still found in modern codes. By 1919 the *Handbook of Fire Protection* noted that defective flues constitute one of the most common causes of fire" and that "in important buildings [sic] the practice of building a flue of brick with

merely [four-inch] walls and without flue lining is little less than criminal."¹⁰

In 1920, the first "Standard Ordinance" for the construction of masonry chimneys was published by the National Board of Fire Underwriters. The Standard Ordinance, which was the antecedent of the current NFPA 211, stated: "All chimneys, irrespective of which material the walls are built, shall be lined with fire clay flue lining or with fire brick. The lining shall be made for the purpose and adapted to withstand high temperatures and the resultant gases from burning fuel." "In the 1921 revision, this absolute requirement was modified to allow residential chimneys at least eight inches in thickness to use one wall of refractory clay brick with a specified severe-service mortar in lieu of tile lining. In an Appendix, this edition pointed out that "all unlined chimneys, irrespective of fuel used, are very liable to become defective through disintegration of the mortar joints.""

In the 1927 edition of the Standard Ordinance, it becomes evident that a great deal of investigation of flue lining material and construction technique had been done in the preceding several years. Detailed requirements for the specification and installation of clay flue linings are described, including the admonition that "no cracked, broken, or otherwise defective linings shall be used." Apparently, concern had been expressed that cracked or broken flue linings were being found in the field, rendering them unsuitable for their intended protective purpose. A new Appendix describes an extensive investigation into the problem which concluded that poor workmanship or methods of installation rather than inadequacy of the flue lining itself were the primary cause. The National Board of Fire Underwriters reaffirmed its strong advocacy of flue lining as "a reliable material and a necessary part of thin-walled [one brick thick] chimneys."

Other sections of the Appendix of this edition took pains to address other practices and concerns which were apparently turned up during the investigation. Among these is the following:

"It has been common practice in constructing unlined brick chimneys to plaster parging mortar upon the inner walls of the flue as the masonry progresses. The fallacy of such substitution for flue lining is evident by examining old flues so constructed. The combined effect of wind,

expansion and contraction due to temperature changes, and flue gases, causes disintegration of such lining. Safe and sound construction prohibits the continuance of this custom."

In a major section on chimney cleaning (sweeping) the Appendix further expressed concern over effects of chimney fires: *"the burning out of a flue is liable to crack the lining or damage the chimney."*

Since the early part of this century, therefore, when the development of standardized building codes and safety standards was in its infancy, the importance of flue lining to the safety and integrity of chimneys has been well-recognized. Flue lining was specified both as an element of the overall fire safety of the chimney and for its ability to protect the chimney wall from premature deterioration. The suggestion that the standard material was becoming cracked and unserviceable in use prompted a major investigation. *The investigation vindicated the material, but a renewed emphasis was placed on construction and maintenance techniques that would ensure that lining remained intact and able to perform its intended function.*

These early requirements were apparently based on fire investigations and field experience. Laboratory investigations into chimney performance during the 1940's further clarified the role of flue lining. Fire incidence statistics for the period show that the abysmal record of fires related to "defective chimneys" had continued unabated since the introduction of the Standard Ordinance, *probably as much due to lack of enforcement as to any inadequacy of the standard itself.* This prompted renewed investigation into the performance of chimneys, this time under the sponsorship of the Housing and Home Finance Agency of the federal government. Much of the research was carried out by the National Bureau of Standards, and the results are summarized in two major reports by Robert K. Thulman and Nolan D. Mitchell.

In his review of the conditions which led to the research, Thulman observed that "the corrosive effect of the acidic content of flue gases...on chimney construction is properly regarded as a hazard," and that "the combustion products of all fuels can produce acid constituents which are equally deleterious to chimney

construction." In recognizing that all significant codes required flue lining, he pointed out that if the flue lining leaks "the condensation will...attack the mortar of the brick work surrounding the flue lining." Therefore, he concluded, either appliances must be operated in such a way that moisture is never present or chimney construction must provide "an impervious lining with any joints made up either with impervious joint material or in such a manner that joint material, if any, is not exposed to liquid products of flue gases." *Ultimately, he suggested that both goals were necessary — design of chimneys to minimize condensation and provision of liners that could fully contain the products of combustion, without leakage.*

The research program also involved investigation of the fire hazards of masonry chimneys. An extensive series of tests in a wide variety of chimneys was conducted with various combinations of exposure to high temperature flue gases. The results were summarized by Thulman, and in more detail by Mitchell.¹³ Among the variables examined was the importance of the presence or absence of flue lining on temperatures developed on the outside of a chimney and on adjacent woodwork. Lined and unlined chimneys were exposed to a variety of flue gas temperatures from 600 to 1300°F. The comparative results are shown in Figure 1-2 which reproduces figures 26 to 30 from Thulman's report.

The presence of lining has a dramatic effect on the exterior temperature of masonry chimneys. Even at a flue gas temperature of 600°F, wood in contact with the exterior surface of the unlined chimney reached a temperature nearly 100 degrees hotter than the lined chimney. Under exposure to 1000°F flue gases (which, it will be remembered, is the current standard for continuous operation with residential chimneys), wood in contact with the unlined chimney actually ignited after only three and one-half hours. Thulman reports that "in view of its obvious inability to provide adequate protection at 600°F, further tests on the unlined chimney were abandoned."

Mitchell's tests also included a series of "heat shock" tests to the lined chimneys involving a rapid rise in flue gas temperature from ambient into the range of 1400 to 1800°F. *The results showed that all of the liners became cracked, and some methods of construction resulted in*

coincident cracking of the chimney wall. Although all of the liners remained in place, some of them were badly broken, introducing the possibility that pieces might fall out during subsequent operation. In view of the concern expressed most clearly by Thulman that linings be capable of containing the products of combustion, *these results showed that incidents of extreme thermal shock could result in a lining no longer able to fully perform its proper function.*

This, of course, did not lead the researchers to condemn flue lining. To the contrary, the conclusions of both reports recommended strongly that current requirements for continuous lining of flues be continued in force. The value of flue lining for reducing fire hazard and protecting the chimney structure, when properly installed and subjected to normal or moderately severe operating conditions, far outweighed the possibility that it might be damaged by abusive conditions. *Furthermore, the ability of the lining to protect the structure even during abusive conditions, even if it sacrificed itself in the process, was recognized.* It was expected then, as it is today, that any damage resulting from untoward circumstances would be repaired to restore the chimney to proper operating condition.

In order to be effective, flue lining must be originally installed in sound intact condition. The writers of the Standard Ordinance were moved to say this explicitly in their 1927 revision, and similar admonitions are occasionally found even in modern handbooks for the masonry trade. Once a lining is put into service, however, it is at the mercy of the operation and maintenance conditions to which it is subjected. Even "normal" conditions within a masonry chimney are not benign. The flue will be exposed to varying temperatures and the corrosive and erosive effects of flue gases and moisture. Despite this unfavorable environment, it is clear expectation of chimney design, as well as codes and standards, that the lining will remain intact.

There are, however, conditions under which flue lining of any type can become damaged. Incidents of thermal shock, such as those created in Mitchell's test and in real-world chimney fires, create stresses on the lining far in excess of those encountered during normal operation, and various modes of failure are a common result. Other hazards, such as the pressure of frozen water admitted by a poor chimney crown, settlement of

the chimney, and lightning are also potential sources of damage to the liner. Just as with any other part of a building, it is expected that chimneys and their linings will be constructed properly and with the ability to perform their function under reasonably foreseeable conditions. It is further recognized that damage and deterioration can occur, so the need for maintenance and repair exists.

Most codes do not directly address the maintenance and repair of chimneys for the very simple reason that they are concerned with the proper initial construction of structures.¹⁴ It is the purpose of codes to establish the minimum requirements for new construction. This does not imply, however, that standards of safety expressed in the code are somehow voided the moment the building inspector leaves the site. If a particular construction feature is important enough to be required for a new structure, it is obviously important to the continued safety of the structure even after it is no longer new. The building inspector may not have the legal authority to force continued compliance with the code after the building is complete, but the authority of the code as a standard for acceptable building performance is in no way decreased.

When codes and standards call for a continuous intact flue lining to contain the products of combustion, as they have for over 70 years, it is their intent that flue lining retain its essential functional characteristics. If it loses the ability to perform its intended function through damage or deterioration, the need for repair is obvious. The fact that most construction codes do not describe specific conditions under which chimneys need to be repaired cannot be construed as "permission" to allow damage to go un-repaired.

In recognition that confusion sometimes exists over the continued importance of its provisions, NFPA 211 has included a chapter on Inspection and Maintenance of existing venting systems." Among the provisions of this chapter is specific guidance on the evaluation of existing flue linings:

"13.9 Damaged or Deteriorated Liners.

If the flue liner in a masonry chimney has softened, cracked, or otherwise deteriorated so that it no longer has the continued ability to contain the products of combustion, (ie. heat, moisture,

creosote, and flue gases), it shall be either removed and replaced, repaired, or relined with a listed liner system or other approved material that will resist corrosion, softening, or cracking from flue gases at temperatures appropriate to the class of chimney service (*See Table 5.2.2.1 in the NFPA 211.*)

In addition, a reference is made to the following notes to be included in Annex A:

"**A.13.9** Deterioration of the interior surface of a liner which results in softening or corrosion of liner materials (eg., powdering or crumbling of liner materials or attack on metal surfaces resulting in perforation) is indicative of the inability of the liner to continue to perform its intended function.

Damage to liners from either structural or thermal causes and results in cracks that would allow moisture to penetrate the liner or would preclude the liner from containing flames or the products of combustion, or both, indicates an inability of the liner to continue to perform its intended function."

NFPA 211, at least, has now made it explicit that the flue lining called for in provisions dealing with new construction is intended to be kept suitable for the performance of its original purpose. If the lining is found to be in a condition which would allow the escape of the products of combustion, repair or replacement is warranted and now explicitly required.

1.3.2 FLUE LINING SYSTEMS

The government-sponsored research projects of the 1940's resulted in a number of recommendations for improvement over the requirements of the "Standard Ordinance" chimney, many of which found their way into the codes and are still in effect today. Among these are the requirements for an absolute airspace clearance between chimneys and any adjacent combustibles and improved rules for installing flue lining. As recommended, most codes have retained an unequivocal requirement for flue lining to be present, but a few codes still anachronistically allow eight-inch thick chimney walls as a substitute.

Nearly all major codes specify flue lining, using language similar to that found in NFPA 211:

7.2.2.1 Masonry chimneys shall be lined.

7.2.3 Low-, Medium and High-Heat Appliances.

(1) Clay flue lining complying with the requirements of ASTM C 315, *Standard Specification for Clay Flue Linings*, or the equivalent, as specified in Table 7.2, Columns III and IV

(2) Fireclay brick complying with the requirements of ASTM C 27, *Standard Classification of Fireclay and High Alumina Refractory Brick*, or the equivalent, as specified in Table 7.2, Columns III and IV

7.2.4 Residential-Type and Building Heating Appliances. The following materials shall be permitted for residential-type and building heating appliances (table 5.2.2.1, Columns I and II):

(1) Clay flue lining of fireclay brick complying with 7.2.3, as specified in Table 7.2, Columns III and IV

(2) Listed chimney lining systems

(3) Factory-built chimneys or chimney units listed for installation within masonry chimneys

(4) Other approved materials that resist corrosion, erosion, softening or cracking from flue gases and condensate at temperatures up to 1800°F (982°C)

The "default" flue lining system is (as it has been since the early part of the century) vitreous clay flue lining. Other lining systems are permitted if they can be shown, either through testing and listing or by other evidence acceptable to the authority having jurisdiction, to perform equivalent to clay lining. A number of different types of alternative linings are in use, and these will be examined separately. However, clay flue lining is by far the most common type of lining found in masonry chimneys and therefore is the type most commonly exposed to chimney fires which are, after all, the subject of this report. In addition, most of the construction and installation requirements of codes relate most directly to clay lining, so it will be examined in the most detail.

Clay Flue Lining

The safety authorities of the early part of the century who pioneered the use of clay flue lining would perhaps be gratified to know that it has become endemic to masonry chimney construction. Particularly since the Second World War, most masonry chimneys have been constructed with clay flue lining. Although even

today some chimneys are built unlined (or with one section stuck on the top, to fool the building inspector), the use of clay lining has become standard.

Clay flue lining is formed from fire clay, surface clay, shale, or combinations of these formed into a tubular shape and fired at a temperature sufficient to partially melt the silica components and form a vitreous (glasslike) consistency. It is very similar in both materials and methods of production to clay drain and sewer tile, and most manufacturers produce both products. Despite the ubiquity of clay flue lining, there are fewer than 20 major manufacturers around the country. These tend to be concentrated in areas with substantial deposits of

the desirable raw materials.

It is used in the code references, but the term "fire clay" flue lining is incorrect and was perhaps at some point in the past a misprint of "fired clay." At any rate, *vitreous clay flue lining need not contain any actual fire clay although some formulations do include a certain amount.* The exact composition of the general class of products is not uniform and depends both on the character of the clays at the location of manufacture and on the particular mixture chosen by the manufacturer. The general manufacturing procedure is standard, but there may be differences in details among the different sources which introduce further variation in the final products. It is therefore difficult to generalize about the specific characteristics and performance of clay flue lining.

Figure 1-2

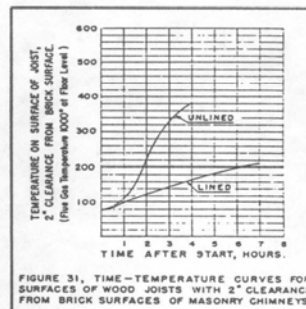
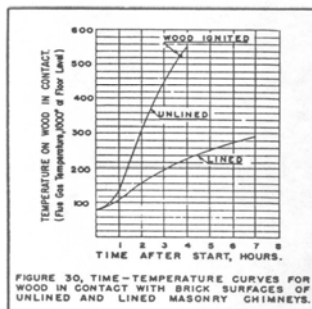
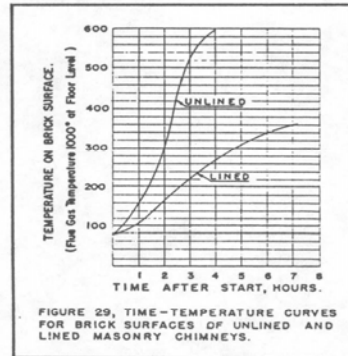
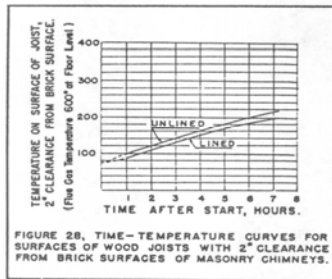
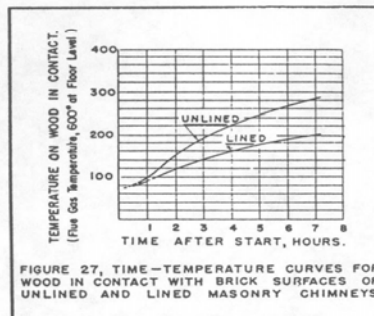
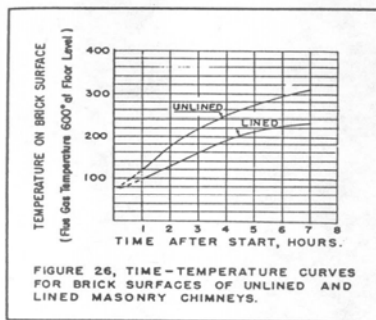

The accepted industry standard for clay flue lining referenced in the codes, ASTM C 315, does provide a basic level of uniformity. (Not all flue linings are manufactured according to this specification, but to be acceptable to the authority having jurisdiction they should be). This standard specification provides minimum requirements for physical and chemical requirements, sizes, dimensions and tolerances, workmanship, and identification.

Shapes, Sizes, and Joints

Flue lining is available in rectangular, round, and oval shapes in a wide variety of sizes and lengths up to two feet square or three feet in diameter by four feet long. For residential applications, only a few of the smaller sizes are generally used, and a two-foot length is nearly universal. Despite their distinct advantages for smooth flue gas flow, round linings are far outnumbered by square and rectangular shapes in the field. Round flue linings are designated by their inside diameter, whereas square and rectangular linings are usually referred to with a rough reference to their outside dimensions.

In addition, these square and rectangular linings can be found in either modular or non-modular dimensions. Within any given size range, the modular sizes tend to be smaller and are intended to be used within the ring formed by arranging modular bricks (with dimensions of seven and one-half by three and one-half inches) to form the chimney wall. The non-modular tiles are intended for use with non-modular bricks (generally eight by three and three-fourths inches) or other non-modular masonry units. Figure 1-3 compares the chimney cross-sections created by modular and non-modular masonry units. When properly matched, these combinations will leave the annular air space between liner and brick called for by the codes (see below). Unfortunately, mismatched systems, particularly non-modular tiles inside modular bricks, are not uncommon.

Although the codes specify a minimum wall thickness of five-eighths inch, all sizes above eight by eight nominal must, per ASTM C 315, be at least three-fourths inch thick. The ASTM specification also sets the standard dimensions and permissible variations for the various nominal liner sizes. The requirements for the most common residential sizes are summarized in Table 1-1.

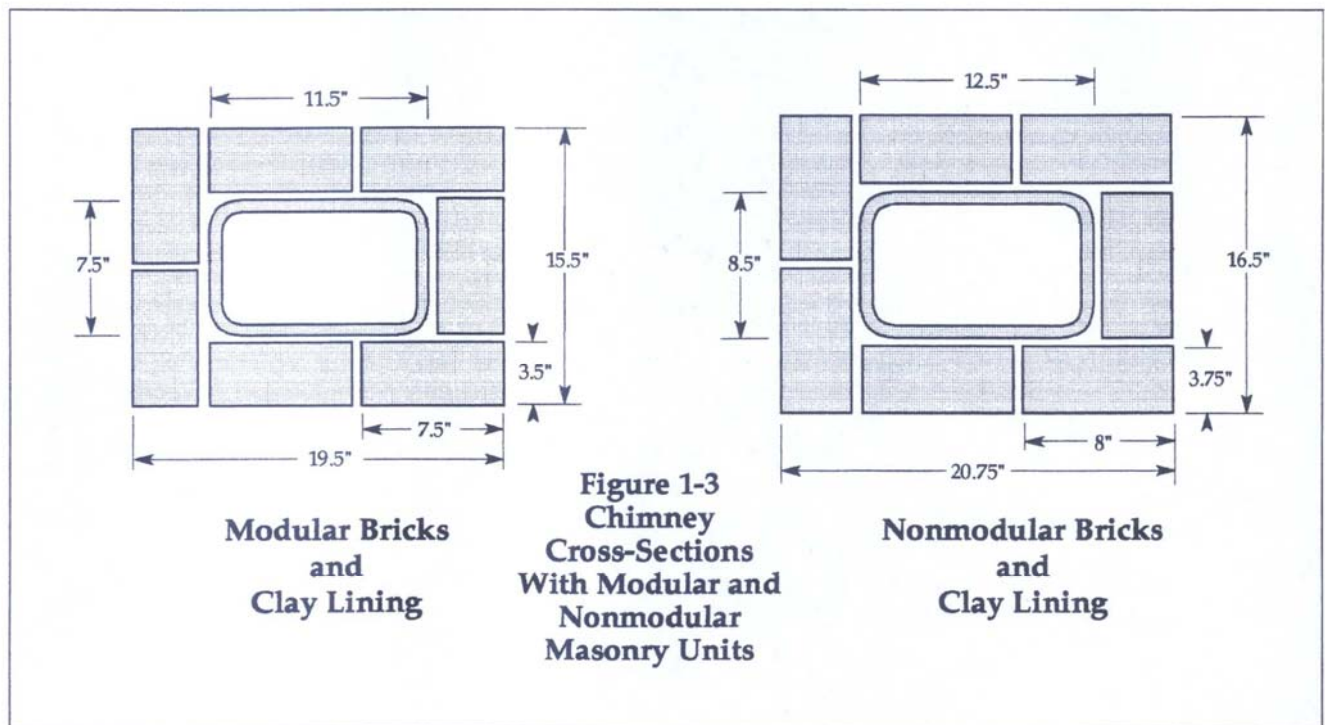

Because clay flue lining is assembled in sections, there will be a joint every two feet. To do their job of containing the products of combustion, the lining joints must be as tight and secure as the rest of the system. Clay lining is available with several joint configurations which offer varying degrees of security.

The most popular joint style, a simple butt joint, is also the least secure and the most subject to errors in construction. Since the ends of the tile do not typically include any inherent means of sealing the joint, they are entirely dependent upon the placement and quality of the cement which fills the gap. The butt joint also does not require that ends be fitted together, so *misaligned tiles, with essentially no ability to contain the products of combustion, are commonly left by careless workers.*

The clay flue lining industry has long offered at least two alternative joint styles which significantly improve the fit and sealing of the lining. With a shiplapped joint, each tile has a male and a female end formed by a ridge near the inner or outer circumference. When sections are properly stacked with the male ends down, the ridges interlock to align the tiles and form a drip-proof joint. Cement must still be included in the joint to fill any uneven surfaces and create a gas-tight seal. One of the advantages of the shiplapped joints is that the outer diameter of the liner is continuous, and it can fit into the same flue space as a conventional liner. However, if slight manufacturing imperfections exist, such as differences in dimension between liners or variations in symmetry, it can cause the ends to not fit together perfectly.

Unquestionably, the most secure joint is the "bell and spigot" type, the same as used for clay drain tile. The flared "bell" end receives the "spigot" end positively, and there is a deep overlap between the two. Joint cement is still used to accomplish a seal, but the joint is much less dependent on precise workmanship than the other two. The disadvantage of the bell and spigot liners, aside from their higher cost, is that the larger diameter of the bell necessitates a larger space for any given flue size. Despite the distinct advantages of both shiplapped and bell and spigot joints, these styles are seldom found in the field.

Manufacturing

The raw materials of clay lining, primarily surface clays and shale, in most cases are mixed together dry, crushed in a mill, and screened to produce a low variation in grain size. Most manufacturers add a small amount of "grog", crushed previously-burned tile material, to the mix. Grog helps prevent shrinkage during the drying process and serves no purpose in the final product since it is re-melted during firing and homogenized with the other clays.

The mixed dry material is delivered by conveyor to the extruder where a measured amount of water is added. The plastic mix is fed by auger to a vacuum chamber, which removes air, and is extruded through a die under high pressure as a continuous tube. For the more common butt-jointed style, sections are cut off to length by a wire. Shiplapped and bell and spigot styles are usually extruded individually by a piston type extruder and then go through an extra step to form the joint. *Liners manufactured to the ASTM C 315 specification are required to be identified by manufacturer or brand name which is embossed into the clay as it leaves the extruder.*

The green tiles are palletized and delivered to the dryer where flowing air of carefully controlled temperature and humidity reduces their moisture content from about 10 to 15 percent to about one percent over approximately a 12 hour period.

Firing of clay flue lining is a precise and crucial process. Its purpose is to heat the raw materials just to their melting temperature so that the particles fuse together; creating a uniform glass-like matrix that is essentially impervious to moisture and gas penetration.

This vitrification process is what defines clay lining as a ceramic material. Different raw materials fuse at different temperatures, and it is necessary to control the time and temperature of firing so that the materials vitrify without cracking, sagging or distortion of the product.

Clay flue lining is fired in either the traditional large dome-shaped kilns made of brick or in modern highly-insulated metal chambers. In both cases, the unfired tile is stacked tightly away from

the sides where the burners (usually gas) are located. Hot gases from the burners rise up the sides and then are drawn down *through* the tiles into a flue system in the floor. This downdraft system ensures more uniform heating of the product throughout the kiln.

The actual firing process follows a long and precise time/temperature curve with several stages. Initially, the kiln temperature is brought slowly up into the range of 600°F during which the remaining water is driven from the clay shapes. A second plateau at around 1400°F is held for several hours in order to burn off any organic material contained in the clay matrix. Finally, the kiln temperature is very slowly raised into the 1900°F range where the actual fusion of the clay bodies takes place. Typical surface clays fuse at around 1950°F. Shales fuse at somewhat less, around 1900°F. The peak firing temperature which is determined by the composition and characteristics of the particular raw materials is held for four to five hours. The temperature of the kiln is then slowly and uniformly reduced to allow the softened material to solidify without developing or retaining residual stresses that would affect the product's performance. The entire firing process lasts about 45 to 55 hours, after which the kiln must be allowed to cool for several days before the finished product can be removed.

Fired clay flue lining ranges in color from a buff to a deep orange. The orange color results from the transformation of iron in the raw material to iron oxide during firing. Most clays, especially the purer fire clays, contain relatively little iron, so they tend to fire to a more buff color while shales tend to add more orange. The presence of iron does not affect the performance of the finished product although it may be indicative of raw materials which have different characteristics.

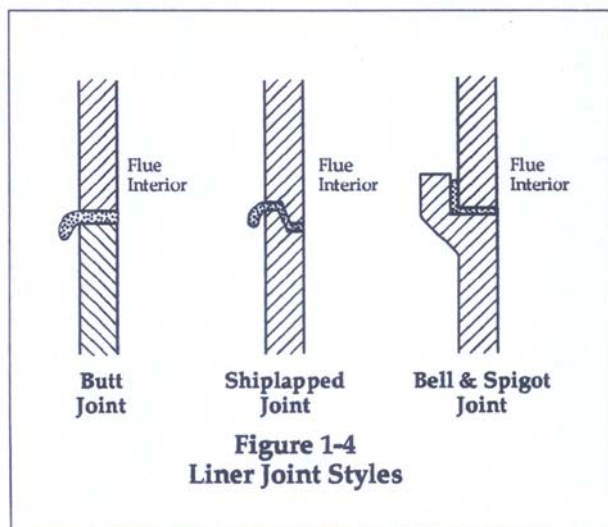

The precision and uniformity of the firing process does affect the acceptability and performance of the product. Under-fired liners may be porous and soft and may retain laminations created by extrusion. If installed in a chimney, particularly near the top, these liners will weather poorly and may be particularly susceptible to spalling from moisture absorption and the action of freezing and thawing. Over-fired liners may be misshapen and excessively glass-like which makes them mechanically more brittle and possibly more susceptible to thermal shock in use.

Finished properly-fired clay lining will be uniformly hard and nonporous through the wall cross-section. Some manufacturers may optionally apply a glaze to the inner wall, but this is not necessary to assure the tightness of the flue. While it is obviously not desirable, material may be abraded or chipped away during use without affecting the ability of the remaining material to contain the products of combustion. However, loss of wall thickness may decrease the strength of the liner, and an exposed rough surface may provide a seat for further deterioration. ASTM C 315 does provide limitations on the amount of blistering or chipping allowed in an acceptable delivered product, and it is clear that flue liners are expected to be installed without cracks or significant imperfections.

Performance Characteristics

Given its essential function of containing the products of combustion, the most important performance factors for clay flue lining have to do with its ability to resist moisture and gas penetration, and corrosion and erosion from those products, and to withstand the heat to which it will be subjected in service. Although it is not strictly a performance standard, ASTM C 315 does set certain standards for *Absorption; Acid Resistance; and Freeze-Thaw Cycles*.

Absorption of water is limited to a maximum of eight percent by weight when tested by the procedure described in another ASTM standard, C 301, *Methods of Testing Vitrified Clay Pipe*. In practice, most properly made clay flue linings exhibit absorption rates as low as three percent. *Some more porous liners which do not meet the standard are manufactured for the market in the southern part of the country where concern over freezing is less.* In general, however, flue lining is essentially impervious to moisture penetration

both by design and specification.

Not all specimens of flue lining are tested for acid resistance since the test is optional. Those that are, however, must not have more than .25 percent acid-soluble matter when tested according to ASTM C 301. Concern over the effect of flue-gas borne acidic condensate from modern, high efficiency gas appliances prompted a very severe test program at the Battelle Laboratories in Columbus, Ohio. A sampling of commercially available linings were subjected to acidic spray chamber testing that involved repeated wetting and drying with concentrated synthetic condensate. It was determined that the essential characteristics of clay lining are not significantly affected by acid exposure.

ASTM C 315 also includes a test for resistance to freeze-thaw cycles. The material must not break nor lose more than .5 percent of its weight when subjected to the prescribed test. More porous tiles may also be subject to erosion from exposure to weather cycles. Hard completely-fired flue lining should not deteriorate even under the

most severe exposure at the top of a chimney.

Like all hard ceramic materials, clay flue lining is mechanically brittle. It is a stiff material that will not deform significantly under load or other stress. It therefore can be damaged by impact or other mechanical forces. When properly used, it should not need to carry much load. It has a relatively high compressive strength ranging from 8,000 to 10,000 psi. Normal use within a chimney should not result in mechanical stress sufficient to cause failure. However, movements of the chimney, such as from settling, particularly if certain construction details are ignored, can lead to damage. The mechanisms of such damage will be discussed in Chapter 4.

The thermal performance of clay flue lining is both one of its greatest strengths and its greatest weakness. For all temperatures likely to occur in a residential venting system, clay lining will remain stable and secure unless it is subjected to a rapid temperature *change*. The absolute temperature to which it is exposed is of no particular consequence. Clay lining retains its essential

Geometry and Tolerances of Typical Residential Flue Liners Based on the ASTM C 315-02

TABLE 1 Rectangular Nonmodular Clay Flue Liners—Standard Dimensions

Outside Dimensions, in. (mm)	Nominal Wall Thickness, in. (mm)	Outside Corner Radius Max., in. (mm)
4½ by 8½ (115 by 215)	⅝ (16)	1 (25)
4½ by 13 (115 by 330)	¾ (19)	1 (25)
8½ by 8½ (215 by 215)	¾ (19)	2 (50)
8½ by 13 (215 by 330)	⅞ (23)	2 (50)
8½ by 17¾ (215 by 450)	1 (25)	2 (50)
13 by 13 (330 by 330)	⅞ (23)	3 (75)
13 by 17¾ (330 by 450)	1 (25)	4 (100)
17¾ by 17¾ (450 by 450)	1¼ (32)	4 (100)
20 by 20 (510 by 510)	1⅜ (35)	5 (130)
20 by 24 (510 by 610)	1½ (38)	5 (130)
24 by 24 (610 by 610)	1⅝ (41)	6 (150)

TABLE 3 Round Clay Flue Liners—Standard Dimensions

Nominal Inside Diameter, in. (mm)	Permissible Variation in Inside Diameter, ± in. ± (mm)	Nominal Wall Thickness, in. (mm)
6 (150)	¼ (6)	⅝ (16)
7 (180)	¼ (6)	¾ (19)
8 (205)	¼ (6)	¾ (19)
10 (255)	⅜ (8)	⅞ (23)
10¾ (275)	¾ (10)	1 (25)
12 (305)	¾ (10)	1 (25)
15 (380)	¾ (10)	1¼ (29)
18 (455)	⅞ (11)	1¼ (32)
21 (535)	⅞ (11)	1⅝ (41)
24 (610)	⅞ (11)	1⅝ (41)
27 (685)	1 (25)	2 (50)
30 (760)	1 (25)	2⅜ (54)
33 (840)	1¼ (32)	2½ (57)
36 (915)	1¼ (32)	2½ (57)

TABLE 2 Rectangular Modular Clay Flue Liners—Standard Dimensions

Outside Dimensions, in. (mm)	Nominal Wall Thickness, in. (mm)	Outside Corner Radius, max., in. (mm)
3½ by 7½ (90 by 190)	⅝ (16)	1 (25)
3½ by 11½ (90 by 290)	⅝ (16)	1 (25)
7½ by 7½ (190 by 190)	⅝ (16)	2 (50)
7½ by 11½ (190 by 290)	¾ (19)	2 (50)
11½ by 11½ (290 by 290)	⅞ (23)	3 (75)
11½ by 15½ (290 by 395)	1 (25)	3 (75)
15½ by 15½ (395 by 395)	1¼ (29)	4 (100)
15½ by 19½ (395 by 495)	1¼ (32)	4 (100)
19½ by 19½ (495 by 495)	1⅜ (35)	5 (130)
19½ by 23½ (495 by 595)	1½ (38)	5 (130)
23½ by 23½ (595 by 595)	1⅝ (41)	6 (150)

TABLE 4 Oval Clay Flue Liners—Standard Dimensions

Outside Dimensions, in. (mm)	Nominal Wall Thickness, in. (mm)	Nominal Outside Corner Radius, in. (mm)
8½ by 12¾ (215 by 325)	¾ (19)	4¼ (110)
8½ by 16¾ (215 by 425)	1 (25)	4¼ (110)
10 by 17¾ (255 by 450)	1 (25)	5 (130)
12¾ by 16¾ (325 by 425)	1 (25)	6⅜ (160)
12¾ by 21 (325 by 535)	1⅝ (29)	6⅜ (160)
16¾ by 16¾ (425 by 425)	1 (25)	6⅜ (160)
16¾ by 21 (425 by 535)	1⅞ (30)	6⅜ (160)
21 by 21 (535 by 535)	1¼ (32)	6⅜ (160)

attributes up to its fusion temperature in the 1900°F range, and even then it is unlikely to do more than soften and sag a bit. However, sudden changes in temperature from the inside of the flue, such as what occurs during a chimney fire, create a temperature gradient through the liner wall. It is the *difference* in temperature, not the particular temperature of either side, which can result in stress sufficient to cause fracture of the material.

Susceptibility to damage by thermal shock is a characteristic shared to one degree or another by all ceramic materials. This tendency has been recognized throughout the history of clay flue lining. It has always been essential that flue lining remain intact during exposure to the normal rising and falling of flue gas temperatures during appliance operation, and history suggests that this has not been a problem. On the other hand, chimney fires and other abusive incidents represent dramatic departures from normal operation and carry the potential for severe liner damage. Thermal shock will be examined separately in Chapter 4 because of its importance in understanding the consequences of chimney fires.

Installation of Clay Flue Lining

Clay flue lining is well-suited for conveying the products of combustion safely to the atmosphere, but it does need to be properly installed in order to perform effectively. Because many installation factors can affect the safety and integrity of the entire venting system, codes have imposed fairly specific requirements which are summarized below.

As a chimney is being built, it has always been tempting for the mason to lay a number of courses of masonry units and then drop a section of flue lining down into the resulting shaft. The problems resulting from this technique were one of the first to be recognized and addressed by codes. The Appendix to the 1927 Standard Ordinance noted that this "has proven to be a very bad practice" and "a cause of leaky and hazardous flues having unsatisfactory draft. "*The primary defect observed today is poorly seated liners not well-aligned with the section below.* If the joint is located two feet below the level of the brick wall, access for adjustment and proper centering is limited. Although setting the liner *first* can also present difficulties, most *codes still require lining to be "installed ahead of the construction of the*

chimney." The chimney wall should then be carefully constructed around the liner.

The codes have long recognized that the material used to seal the joint between liner sections needs to have special characteristics. No matter how impervious the liner material itself, the joint will always be the weakest link in the system unless the joint sealant can withstand the rigors of flue gas venting equally well. *It has, unfortunately, been common construction practice to not use any special material at liner joints; rather, most masons simply set the tile with the same mortar used between bricks. As a result, eroded leaking joints are virtually endemic to residential chimneys.*

The early chimney construction codes, such as the Standard Ordinance, required mortar used between flue liners to be rich in Portland cement. More recently, this was changed to "refractory" mortar (which presumably included fire clay) with an unspecified binder. Although not all codes have so far followed suit, NFPA 211 now requires a "non-water-soluble...refractory cement mixture" using calcium aluminate as a binder, or equivalent. Portland cement bonded mixtures are specifically excluded. Many of the older refractory mixes used sodium silicate (water glass) as a binder. Although easy to work with, this material requires the application of heat for proper curing. Unless the chimney is raised to the proper temperature, the sodium silicate may remain soluble. In view of the importance of resistance to erosion and attack by acids, insoluble binders are now specified.

Modern standards also call for "close fitting joints left smooth on the inside." Whatever the material used, the joint will be both stronger and more able to resist attack if a minimal amount of cement is exposed. Only enough cement should be used to seal any unevenness between the ends of the liner and provide a bond. Projecting "fins" of joint material will also interfere with flue gas flow, trap moisture, and provide a natural location for attack by the acids. Any cement squeezed out on the inside of the flue should be struck off and wiped smoothly over adjoining surfaces. *Because it requires reaching down inside the flue, this step is frequently omitted, with negative results on chimney performance.*

One of the more significant installation factors is the requirement found in most (but not all) codes, here quoted from NFPA 211, that flue lining be

"separated from the chimney wall by a minimum of 1/2 inch and a maximum of four inches of air space. The air space shall not be filled and only enough mortar [sic] shall be used to make a good joint and hold the liners in position." For a number of reasons, it is necessary that the chimney wall and flue liner be independent of each other. During operation, the warm liner will expand very slightly in a radial direction (outward) and to a greater degree axially (lengthwise). In order to accommodate this movement, the liner must not be anchored tightly to the chimney wall. Furthermore, the chimney wall, as a structural element resting on the ground, may settle or be subject to other movements during its life. It is essential that any strains which result not be transferred directly to the brittle liner which may crack. *Failure to separate the liner and chimney wall is a major factor in many causes of chimney damage.*

In addition, it is the air space between the liner and chimney wall which makes the presence of flue lining effective at reducing temperatures on the exterior of the chimney. Although it cannot be said that a space filled with mortar completely negates the beneficial effect of the liner, there is no question that under steady heating the exterior temperature will be higher than if the air space were present.

Alternative Lining Systems

Clay flue lining is the established "default" lining recognized by the codes, but all codes provide for the use of "equivalent" systems or materials. Until relatively recently, there were very few alternative materials in use. The last decades, however, have seen the development of a wide variety of systems intended to perform the same function as the traditional clay lining. Both clay linings and the alternative systems have characteristics which lend themselves to different installation circumstances.

Clay lining is still, by far, the most common material used in new construction. Most of the alternative systems were developed in response to the need for retrofitting a liner to previously unlined chimneys or to replace damaged existing liners. Clay liners can, of course, be inserted into existing chimneys, just as alternative systems could be used as original equipment for a new chimney, but the difficulty of properly lowering, aligning, and sealing clay liners by "remote control" makes

them less suited to this application. Special devices are available for holding and aligning tiles as they are lowered down the chimney, but even with this equipment many chimneys simply cannot be relined with clay lining.

Offsets within the chimney would be impossible to accommodate without breaking open the shell or chase.

By the same token, both the economics and the installation characteristics of alternative systems make them less attractive for new construction. Because they are generally adaptable to retrofit situations, alternative systems are often known, incorrectly, as "relining" systems.

NFPA 211 addresses relining in much the same way it addresses original lining:

7.1.10.1 Where masonry chimneys are relined, the liner shall be listed or of approved material that will resist corrosion, softening, or cracking from flue gases at temperatures appropriate for the class of chimney service.

7.1.10.2 Listed liner systems shall be installed in accordance with the listing.

7.1.10.3 Approved materials shall be installed in accordance with Section 7.2.

7.10.4 The relined chimney shall meet the requirements for the class of chimney service.

Note that the language used to describe relining systems is identical with that used to provide for alternative original-equipment flue liners. Furthermore, the second paragraph makes it clear that the end result of relining should be the creation or restoration of a chimney that meets all of the performance criteria for that type of chimney. Thus the distinction between lining and relining systems is, at most, blurred. Both are intended to have the same performance characteristics and perform the same function in a working chimney system.

Alternative systems must be shown to be "equivalent" to the accepted benchmark of clay flue lining. For residential type chimneys, "approved" systems are those composed of generic materials accompanied by sufficient evidence to convince the authority having jurisdiction that they will "resist corrosion, softening, or cracking" under the 1000°F continuous flue gas temperature standard and up to 1800°F. A more certain and increasingly popular way for alternative linings to demonstrate equivalence is

to become "listed" by a nationally recognized agency.

The most widely recognized standard for testing and listing flue liners is UL 1777, *Chimney Liners*. This standard, which was first published by Underwriters Laboratories in 1988, examines a number of thermal and mechanical properties of the lining system related to its ability to contain the products of combustion and minimize chimney temperatures. The core of the test program involves installation of the liner in a standardized masonry chimney surrounded by combustible material. Flue gases at 1000°F are introduced into the liner and held for up to eight hours while temperatures on the enclosure are monitored. Additional tests are run with 1400°F flue gases for one hour and for three 10-minute exposures at 2100°F.

During all tests, the liner must survive intact and prevent temperature rises on the enclosure above certain conservative limits. The enclosure may be placed at either the one-inch minimum clearance allowed by codes, or, at the manufacturer's option, in contact with the chimney exterior. *The latter "zero clearance" option was developed in recognition that many existing chimneys have been incorrectly constructed without proper clearance, but that a sufficiently insulated lining system may be able to compensate for the error and develop a level of safety equivalent to a conventional chimney with proper clearance.*

Listed lining systems are also subjected to a series of tests which demonstrate the strength and durability needed to contain the products of combustion under the anticipated conditions of service. Successfully tested products are eligible to bear the label of the testing agency which provides a means for recognizing a listed product in the field. Listed lining systems must be provided with instructions or a contractor's manual which describes the components and techniques necessary for proper installation, together with specified limitations and safety information. While codes spell out the installation criteria for clay flue lining, listed lining systems are to be installed in accordance with the manufacturer's instructions.

Anytime a lining system is to be retrofitted into an existing chimney, full inspection and preparation of the chimney is crucial. The chimney must conform to the requirements of recognized standards such as NFPA 211 in all respects except for its

current lining. It must be free of significant defects and deterioration such as missing bricks or mortar joints and must be repaired as necessary before relining. The chimney must also be thoroughly swept prior to installation of the liner to prevent smoldering or ignition of any residual deposits. The NFPA level II inspection is indicated.

It is not always required that alternative lining systems be listed, but most currently are. Some local codes do not allow the use of unlisted chimney linings other than the historically-proven clay lining. Given the important role which lining plays in the performance of a chimney, listed linings, which come with explicit installation instructions and which have proven themselves through rigorous testing, have a distinct advantage over unlisted substitutes. Following is a brief review of the characteristics of the different types of lining currently available.

Stainless Steel Lining Systems

Stainless steel has long been used as a lining for factory-built chimneys and is readily adapted for use in masonry. It is relatively easy to work with and does not require highly specialized equipment. It provides a nonporous surface and is resistant to high temperatures and corrosion from normal flue gases.

Originally, type 430 stainless was used for both factory-built and masonry linings. Now most linings are made of one of the 300-series alloys containing higher percentages of both chromium and nickel for increased corrosion resistance. Type 304 is a readily available general purpose stainless used most commonly. Some liners are made from type 316 or the stabilized 321 alloys, or the specialty steel AL-29-4C, for better resistance to some acids and to heat sensitization and inter-granular corrosion. All of the types should be expected to provide a reasonable service life under normal maintenance.

Stainless liners are found in round, oval, and rectangular shapes. The round shape allows the least resistance to flue gas flow but will not fit within many existing rectangular chimneys. For this reason, ovalized liner is sometimes used. More recently, rectangular liners have become available that closely match the interior dimensions of rectangular fire clay flue liners.

Just as with clay flue lining, stainless steel liners require space between the liner and the

surrounding masonry wall to limit temperatures on the chimney exterior. However, in order to pass the stringent limitations of UL 1777, most stainless systems must use some form of solid high-temperature insulating material rather than an air space. When they were first introduced, many stainless liners were insulated with a loose fill of vermiculite or similar material. This is no longer allowed because of concern for settling and sifting of the material into the flue. There are two major types of insulation now in use: 1) a wrap of foil-faced ceramic fiber blanket and 2) a poured-in-place masonry fill. The blanket is wrapped around the liner before insertion, covered with an abrasion-resistant wrap, and lowered into the chimney as a unit. The masonry fill is a damp mixture of Portland cement and expanded mineral such as vermiculite. It is poured into the chimney around the liner and allowed to cure. Listed stainless liners must provide a specified amount of space around the liner to allow the proper thickness of insulation.

Stainless liners are found in two major forms: rigid and flexible.

Rigid Stainless: Rigid stainless lining is formed similar to standard stovepipe, with either a welded or hammer-locked longitudinal seam. It comes in lengths of up to four feet and is usually found in 22- or 24-gauge thickness. Sections may be pre-assembled in multiple lengths before being taken to the roof or added one on top of the other as the liner is lowered down the chimney. The joint between sections must be fluid-tight and held together with stainless steel rivets (screws are no longer allowed). Rigid systems are supported by the bottom of the chimney or a flat plate installed in either the top of the chimney, or in the case of a fireplace, the bottom of the flue liner. Because rigid stainless will expand significantly when heated, the top of the chimney must be capped in such a way as to allow the liner to expand freely though the top while still preventing the penetration of water around the outside. This is accomplished with the use of a "top plate". A support bracket can be attached to the liner that will both support the weight and allow for any expansion.

Flexible Stainless: Flexible stainless liners can be inserted in chimneys with offsets and are useful for connecting stoves and inserts through fireplaces. There are two ways of making a flexible liner. One type uses a stainless steel strip

to form a corrugated liner. The other uses an interlocked spiral of stainless bands to form a flexible tube. Both types usually come in a continuous pipe, often 25 feet long. Lengths may be joined together and other adapters are used to form tees and other components. The liner is usually lowered as a unit from the top of the chimney or pulled up from the bottom. Most flexible liners are supported from the top, but some specify both top and bottom support systems. They can expand on heating, but usually the flexible design absorbs the expansion throughout the length of the liner.

Cast-In-Place Liners

Cast-in-place liners use a cementitious mixture containing insulating mineral pellets such as perlite. They are formed within the chimney such that they adhere to the chimney walls, leaving a smooth continuous flue in the middle. They are chemically inert to most common corrosives and perform well at high temperatures. Their lightweight concrete consistency provides enough give to allow for thermal expansion without an air space and to absorb the effects of thermal shock. The insulating mineral in the mix provides enough resistance to the flow of heat to allow the material to be poured against the chimney walls without an additional insulating air space. The flue can be formed in either round or oval shapes and in sizes large enough to serve commercial and industrial chimneys.

The slightly porous surface of cast-in-place systems can absorb some moisture, but they must pass a rigid absorption and freeze/thaw test in order to be listed. The surface is softer than normal concrete and can be scraped by repeated chimney brushing, a characteristic which is also limited in the listing tests. Some systems provide a glazed final coating to the flue to minimize these problems.

There are two major types of cast-in-place systems known more for convenience than accuracy as the English and German methods. Both methods add significant strength to the chimney when dry and fill in gaps and irregularities in the chimney wall, resulting in a seamless continuous flue. Both add significant weight and thermal mass to the chimney. The English method, because of its wetter mix, can subject the bottom of the chimney to considerable hydrostatic pressure before drying. Although preparations can often be made to prevent it,

blowouts of weak areas of the chimney have occurred. The German system, which uses a mix with a much drier consistency, must be carefully blended with the correct amount of water and has the potential for difficulties with the mix not adhering to chimney walls and falling out before drying. In both cases, the chimney must be thoroughly inspected and cleaned before a cast-in-place system is attempted.

English Method: In this system a long firehose-like bladder is lowered into the chimney and held away from the walls by spacers. The tube is inflated with air under pressure, and the lining mix is pumped from the ground into the surrounding space. The mix is fluid enough to flow into holes and mortar joints in the masonry walls, which may help to strengthen the chimney structure. After the concrete has hardened, the bladder is deflated and removed, leaving the formed flue. The minimum thickness for such linings depends on the manufacturer's specifications. *Typically, a thickness of three-fourths to one inch is necessary for chimneys with at least one inch of clearance to combustibles; for chimneys with less clearance, a wall thickness of one and a half inch is more common.*

German Method: This method employs a bell-shaped metal slip-form with a vibrating motor inside. The bell is suspended from a cable and is drawn up from the bottom of the chimney. The liner mix, wetted to a damp, zero-slump consistency, is poured around it. The vibrator forces the mix into the walls of the chimney, leaving the formed flue behind. This installation method requires that the lining be thicker than for English systems, usually a minimum of one and a half inches, which covers chimneys both with and without the one-inch clearance to combustibles.

Modular Masonry Systems

Modular masonry flue lining systems are in some respects similar to vitreous clay lining systems in that they consist of tubular sections of ceramic or masonry material that are progressively joined and stacked within the chimney. They differ from clay lining in that they are supplied as complete systems with a number of components rather than as generic materials. Most are listed and are assembled according to specific instructions. Most of the systems are imported or adapted versions of systems that have been used in

Europe for some time. Some are formed from volcanic materials bound together by a cementitious mixture while others are an actual fired ceramic tile. Most appear to be porous but must pass water absorption and freeze/thaw testing in order to become listed. The porous nature also appears to increase their inherent insulating ability. Some relatively thick-walled versions can be installed with only an air space between the liner and chimney wall while others use a backfill of additional insulating material

NOTES

1. Some residential appliances are designed or listed only for use with a specified vent or a particular brand of factory-built chimney. These exceptions do not invalidate the general rule that appliances and chimneys are intended to be matched by their general service category.
2. Except for decoupled appliances such as most gas burning equipment, conventional gas appliances typically include a draft hood which provides an atmospheric break between the vent and appliance. However, the draft hood allows the entry of dilution air, which is an important element in the safe venting of gas appliances. Combustion air for conventional gas appliances is supplied by the venturi-type burner and the small amount of draft caused by rising gases within the appliance.
3. Although the literature on the low-temperature ignition of wood is extensive, the most comprehensive resource is Part II of *Performance of Type B Gas Vents for Gas Fired Appliances*, Underwriters Laboratories, Bulletin of Research No. 51, May 1959.
4. NFPA 211, *Chimneys, Fireplaces, Vents, and Solid Fuel Burning Appliances*, (2006 Edition), National Fire Protection Association, Quincy, MA, (Unless otherwise noted, all references to NFPA 211 are to the 2006 edition.)
5. *Technical Notes on Brick Construction*, No. 19B, "Residential Chimneys: Design and Construction," Brick Industry of America, Reston, VA, 1980.
6. International Code Council. The International Code Council (ICC) was established in 1994 as a nonprofit organization dedicated to developing a single set of comprehensive and coordinated national model construction codes. The founders of the ICC are Building Officials and Code Administrators International, Inc. (BOCA), International Conference of Building Officials (ICBO), and Southern Building Code Congress International, Inc. (SBCCI). Since the early part of the last century, these nonprofit organizations developed the three separate sets of model codes used throughout the United States. Although regional code development has been effective and responsive to our country's needs, the time came for a single set of codes. The nation's three model code groups responded by creating the International Code Council and by developing codes without regional limitations the International Codes.

7. *Wood Energy Technical Training Manual*, Canadian Wood Energy Institute, Minister of Supply and Services, Canada, 1987.
8. Everett U. Crosby and Henry A. Fiske, *Handbook of Fire Protection*, Fourth Edition, The Insurance Field Company, Louisville, KY, 1909.
9. William D. Matthews, E. E., *The Insurance Engineers' Handbook*, The Insurance Field Company, Louisville, KY, 1916.
10. Crosby, Fiske, H. Walter Forster, *Handbook of Fire Protection*, Sixth Edition, D. Van Nostrand Company, New York, 1919.
11. *An Ordinance for Construction of Chimneys*, National Board of Fire Underwriters, New York, 1920.
12. Robert K. Thulman, *Performance of Masonry Chimneys for Houses*, Technical Paper No. 13, Housing and Home Finance Agency, 1949.
13. Nolan D. Mitchell, National Bureau of Standards, "Fire Hazard Tests With Masonry Chimneys," *NFPA Quarterly*, National Fire Protection Assn., October 1949.
14. Most of the regional model building code organizations publish codes regulating the condition of existing properties, such as the *National Property*

Maintenance Code, and individual states may have adopted their own versions. Such codes address structures built prior to the current Building or Mechanical Code, and provide requirements necessary to maintain a basic level of safety in buildings that may not meet current construction requirements. They are not intended to supplant the requirements of current codes, nor to permit the deterioration of features that were required when the structure was built. With respect to chimneys, most such codes simply require that they be kept in "good repair," or "reasonably safe," without specifying particular characteristics. Unless specific allowances are made, it is the intent of such codes that the chimney be maintained in its original operating condition.

15. This and other revisions to NFPA 211 are still subject to Committee letter ballot, approval by the membership in attendance at the Annual Meeting, and final issuance by the NFPA Standards Council. Proposed revisions may be found in the Annual Meeting *Technical Committee Reports and Technical Committee Documentation* available at no charge from the National Fire Protection Association, 1 Batterymarch Park, Quincy, MA 02269.

16. See note 11. Curiously, the Standard Ordinance required that the liner be set first and brick built around it so that the annular space could be completely slushed with mortar, which is the opposite of most current code requirements.

Chapter 2:

Behavior and Effects of Chimney Fires

2.0 INTRODUCTION

Chimney fires are among the more common types of fire incidents reported in the United States, so it follows that they have been experienced by a large number of people. This body of experience has been sufficient to build a thorough qualitative understanding of the nature, extent, and phenomena associated with chimney fires. More recently, concern over the safety ramifications of chimney fires has prompted significant laboratory research into their characteristics and effects. Such sophisticated research has, for the most part, confirmed observations from the field and has generated considerable data on the thermal performance of chimney fires.

This chapter reflects both the qualitative and quantitative aspects of the knowledge about chimney fires. Section 1.2 produces a working definition of the concept of “chimney fire.” Section 2.2 summarizes the general characteristics of creosote, the primary fuel for chimney fires. Section 2.3 provides a general description of chimney fires based on the collective experience of fire fighters, homeowners, and chimney service personnel and supplemented by the observations of laboratory researchers. Section 2.4 focuses on the thermal performance of chimney fires – both of the fire itself and its dynamic effects on the chimney structure. Finally, the post-incident signs of chimney fire occurrence and damage patterns produced are explored in section 2.5.

The Chimney Safety Institute of America is indebted to Richard Peacock of the National Institute for Science and Technology, Center for Fire Research, and Richard L. Stone, former Director of Research and Engineering, Metalbestos Systems, for their help with this chapter. The published research of both gentlemen has contributed greatly to the understanding of chimney fires and both offered suggestions and insights from their testing experience. Mr. Peacock also provided details of the published data and charts which have helped in the characterization of the thermal performance of masonry chimneys under both normal and abnormal conditions.

2.1 DEFINITION OF “CHIMNEY FIRE”

Although the concept of “chimney fire” may be understood almost intuitively by most people, it would be well to define its parameters as used in this report.

Used most broadly, the term “chimney fire” can encompass any fire incident which is related by cause or proximity to a chimney. It has been used this way in several surveys of fire incidents related to wood heating, most notably those by the Consumer Product Safety Commission¹ and by TriData Corporation for the Wood Heating Alliance.² Unfortunately, this definition includes incidents related only nominally to the chimney and when the chimney itself may not have been subject to abnormal operating conditions. When referenced in this report, therefore, the term “chimney-related fires” will be used for this broad application, and “chimney fire” will be reserved for more precise usage.

“Fire” is usually defined in terms of “combustion”: the rapid oxidation of a material accompanied by the production of heat and light. *This definition excludes many chemical reactions which, while they may involve oxidation and even produce heat, do not simultaneously produce light.* On the other hand, the definition does not set a lower limit on the *amount* of heat nor specify a particular type of light. Therefore, “fire” includes both flaming and blowing combustion which is, to some degree, exothermic.

In the context of this paper, “chimney fire” refers to the presence of actual combustion within some part of a venting system. Although usually applied mainly to the chimney flue, this usage also includes combustion in chimney connectors and thimbles and the smoke chambers of fireplaces. Since venting systems by definition are not intended to host actual combustion, a chimney fire always represents an abnormal operating condition.

Two conditions need to be addressed which, while included in the definition, are not primary subjects of this report. It has been occasionally observed in the field and in the laboratory by Shelton³ that

gases given off by combustion in an appliance can ignite and burn separately in the venting system. Although this phenomenon will be discussed briefly, the primary focus is on fires where the fuel is present in the venting system.

Chimney fires can also involve burning of combustible materials – such as leaves or bird’s nests – which originate outside the heating and venting system. Again, these fall within the scope of chimney fires but not of this report.

As used in this report, “chimney fire” refers primarily to the burning of organic material present within a venting system, the origin of which is incomplete combustion of a fuel in an appliance. The burning material can be lumped under the general term “creosote” which includes a variety of compounds and forms from dry carbon soot to viscous semi-liquid tars. For clarity, the phrase “creosote chimney fire” will sometimes be used.

It should be noted that for legal or insurance purposes the definition of fire and its implications for chimneys may be similar but not identical to that above. For instance, fire can include the effects of fire remote from actual combustion (smoke and heat, for instance) and the results of extinguishment efforts. The application of the fire peril in insurance policies will be discussed more completely in Chapter 5.

2.2 CREOSOTE

The origin, accumulation, and chemistry of the complex materials known as creosote could probably fill a separate chapter if not an entire book. Such a detailed discussion is beyond the scope of this report. However, a general discussion of the varieties, forms and behavior of creosote is necessary for an understanding of the dynamics of chimney fires.

The creosote found in chimneys should first be distinguished from the “creosote” found in railroad ties and wharf pilings. The latter term refers to a derivative of coal tar used as a preservative. A specific chemical that goes by the name of “creosote” is one of the ingredients of both coal tar and chimney creosote. Coal tar creosote may not be chemically dissimilar to some types of chimney creosote, but the literature on such preservatives does not necessarily apply to deposits in chimneys.

The term “creosote” can be used either broadly or specifically, depending on the context of the discussion. Since in this report “chimney fire” means the burning of organic deposits in the venting system, “creosote” will refer to any such combustible deposits which originate from incomplete fuel combustion in a connected appliance. Thus creosote does not include collection of fly ash or water, both of which may be present along with creosote.

Sometimes a distinction is drawn between creosote and soot. This can be a useful distinction since soot looks, feels, and acts differently from other chimney deposits. We will, occasionally, separately discuss deposits in which soot predominates. However, both soot and other forms of creosote are organic, combustible, and the result of incomplete combustion, and both can fuel chimney fires. Therefore, the general discussion of creosote includes soot.

Although usually associated with wood burning, creosote is not limited to chimneys which serve wood-burning or even solid fuel appliances. The combustion of coal, oil, and natural and LP gases can be incomplete in the appliance, and it can result in venting system deposits. Chimney fires have occurred in the venting systems of liquid and gas fueled appliances, but they are uncommon.

Creosote, as deposited on chimney walls, is a collection of substances which range from the simple elemental molecules to complex, polycyclic, aromatic hydrocarbons. The composition of this mixture is not uniform or predictable. Attempts have been made to describe the major components of creosote through analysis of the products of wood distillation,⁴ and it is likely that the deposits in chimneys reflect such patterns in a general way. However, the deposit in any given chimney is unique and depends on many factors including but not limited to: the type of fuel burned; its species and moisture content; type of appliance and modes of operation; details of the size, shape, length and heat transfer characteristics of the venting system; and environmental conditions. It is likely that the nature of the deposit changes from day to day and fire to fire and even with the different phases of the fuel cycle.

Perhaps the most useful discussion on the nature of creosote is about the forms it takes in chimneys and the transformations it undergoes. Since all

forms of creosote originate from incomplete combustion in an appliance, this becomes the place to begin tracing the “life cycle” of creosote. This discussion will concentrate on creosote from wood fuel but is also relevant to coal and, with respect to soot formation, to oil and gas.

2.2.1 ORIGINS OF CREOSOTE: WOOD COMBUSTION

Wood (and some types of coal) is chemically and structurally the most complex fuel in use today.⁵ Unprocessed fuel wood is primarily composed of the carbohydrates cellulose and lignin which are built from various combinations of carbon, hydrogen, and oxygen. This wood also includes moisture, pitch and resins of various chemistry, and minerals which form the basis of noncombustible ash. These materials are not necessarily uniformly distributed through the fuel. One form of cellulose has the chemical formula $C_6H_{10}O_5$.⁶ For comparison, methane, the primary component of natural gas, has the relatively simple formula CH_4 . The process of wood combustion is necessarily complex and is rarely complete.

Wood itself does not burn. The molecules which make up wood are stable under normal conditions – they have no tendency to recombine with other materials, including oxygen. *In order to initiate combustion, wood molecules must be destabilized.* The usual method of destabilization is the application of energy in the form of heat. *Wood must be ignited.*

The application of heat to wood begins a process called pyrolysis, which is the breakdown of stable molecules into simpler and often less stable compounds. Pyrolysis has been discussed in Chapter 2, in the context of long term heating of combustible building components. Essentially the same process occurs when wood is heated quickly although the details of the chemical reactions may be somewhat different. From a practical standpoint, the major difference between fast and slow pyrolysis is what happens to the decomposition products. In slow pyrolysis, the main product of interest is the solid charcoal left behind. In a wood fire, charcoal is also left behind, but the process happens quickly enough that gaseous and liquid compounds are also produced in large amounts and are extremely important to the combustion process.

In an actual wood fire, this is an ongoing process.

Different parts of the fuel are undergoing pyrolysis and are in different stages of the process at different times. The products of pyrolysis are made up of the same basic materials – carbon, hydrogen, and oxygen – as was the original fuel but in different combinations. Some of these are in the form of gases (including methane as well as more complex hydrocarbons), some solid particles (mostly carbon), and some liquid droplets (a collection of less-volatile hydrocarbons referred to as tar fog).^{6, 7} Together, the products given off by the pyrolysis of wood are known more commonly as smoke. The completion of pyrolysis leaves behind charcoal which is composed primarily of carbon.

The burning of wood is more accurately the burning of smoke. If the products of pyrolysis enter a region of high temperature (usually adjacent to the surface of the wood, in an area of ongoing combustion), they will be further broken down into unstable molecules. If sufficient air is available, they will recombine with oxygen (“oxidize”), and, in the process, release substantial heat. This heat is then available to continue the process of breaking down the components of smoke as it enters the combustion zone. The burning of smoke takes place in and is responsible for the flames that are a familiar part of burning wood. The solid charcoal left behind burns only with a glow and no flames, but it contributes heat to the flaming combustion process.

If the oxidation process is carried to completion, the carbon, hydrogen, and oxygen of the fuel will be completely transformed into just carbon dioxide (CO_2) and water (H_2O). In practice, wood combustion is rarely complete. *In order for combustion to occur, an oxygen molecule must collide with a fuel molecule with enough force to weaken the bonds that hold each together and to allow the formation of a new combination.* The oxygen must be present at the exact time and place where enough heat is available to cause the reaction. Since the oxygen must diffuse into the flame from the surrounding air, there is no guarantee that such a favorable coincidence will occur.

The completeness of wood combustion is in direct proportion to the availability of air and its successful diffusion into the high temperature combustion zone at the same time that pyrolyzed fuel is available for combustion. In the unsophisticated environment of a conventional

wood stove or fireplace, some of the products of pyrolysis will inevitably escape and be carried into the venting system *Smoke is simply pyrolyzed wood fuel that did not burn in the appliance, and creosote is simply smoke that didn't make it out the top of the chimney.*⁵

2.2.2 METHODS OF CREOSOTE ACCUMULATION

There are several mechanisms by which smoke is deposited as creosote within the venting system. In any given chimney, the predominant mechanism and the nature of the initial deposit depend on the composition and density of the smoke and on the geometry and heat transfer characteristics of the venting system. The primary mechanisms are condensation of gases, contact adhesion of liquids and tars, and trapping or settling of solid particles.

The relative proportions and composition of the gases, liquid tars, and solid carbon particles in smoke depend on the speed at which pyrolysis takes place and the intensity of combustion in the appliance.⁷ Under slow pyrolysis, a greater percentage of the wood will turn into charcoal and a lesser percentage into tar and flammable gases. More rapid heating of the fuel generates relatively less charcoal and more hydrogen-rich gases and tars. On the other hand, where air is plentiful and combustion zone temperatures are high, the gases and tars are more likely to be consumed. In these cases, the smoke escaping the appliance may be composed primarily of soot which is formed by incomplete combustion of carbon particles in yellow-orange flames. When the air supply is limited or poorly-mixed or temperatures are low, tars and vapors are less likely to be consumed and will form a large proportion of the smoke entering the venting system.

Thus, two extremes of smoke composition and density can be described and related to real-world conditions. *Under conditions where heat is propagated relatively slowly through the fuel, yet air is freely available (as in fireplaces and open stoves), smoke is likely to be less dense and composed mainly of soot. In closed appliances (such as airtight wood stoves) where the fuel is heated relatively quickly but burned under air-limited low-turbulence conditions, smoke will be dense and rich in tars and volatile hydrocarbons.* The most extreme example would be when a load of wood is placed in an already-hot stove but

allowed to only smolder with no flames at all.

In cases where the smoke composition is dominated by volatile hydrocarbons, condensation from the gas phase to liquid phase on cool flue walls will be the dominant mode of creosote deposition. Where smoke is composed primarily of liquid tar droplets (which are already condensed) or solid carbon particles, simple sticking of the material on contact with the flue walls will be more important. In the first case, the temperature characteristics of the flue gases and chimney will be the critical factors in the amount of deposit. In the latter case, factors which affect the likelihood of smoke particles randomly contacting the flue walls will be more important than temperature. In practice, real smoke contains at least some materials of all three types, so both groups of deposition factors are important.

Shelton has summarized the variables which appear most important for the deposition of creosote:⁸

- Smoke density
- Temperature of the flue walls (and of the flue gases)
- Residence time of the smoke in the flue
- Turbulence of the smoke

All of these factors can affect both condensation of gases, contact adhesion of liquid droplets, and adhesion or fallout of solid particles in different ways.

The *smoke density* affects both the dew point of the gases and the concentration of liquid and solid particles. The greater the concentration of gases in the smoke mixture, the higher its "humidity". The higher the humidity, the higher the dew point (the temperature below which the gases will begin to condense and become liquid). The flue gases contain a variety of different hydrocarbon gases, each with its own concentration-dependent dew point, so there is no single critical temperature. *Greater smoke density always makes it more difficult to keep the condensables in the gas phase and get them out the top of the chimney.*

A dense concentration of liquid tar droplets or solid particles in the smoke simply increases the statistical likelihood that a certain number will come in contact with the flue surface and stick. For the liquids, the effect is almost identical to that of an aerosol spray paint. The tiny droplets simply stick where they hit. Carbon particles tend

to collect in chains or clumps which *then tend to get caught on even tiny irregularities in the flue surface.*

The *temperature of the flue walls* has more to do with the condensation of hydrocarbons into creosote than does the flue gas temperature. *Regardless of their temperature, if the flue gases pass across a surface that is below their dew point, they are likely to condense.* The gas temperature is not completely irrelevant if for no other reason than the fact that it is the hot gases that warm up the wall in the first place. The ability of the walls to retain heat and stay above the gas dew point is more critical than the actual gas temperature, however. Poorly insulated walls and chimneys exposed to cold surroundings are more likely to collect more condensable creosote.

Neither the flue gas nor flue wall temperature has a direct effect on the liquid tars or solids since they are already condensed. Low entering flue gas temperatures, however, are one indication of low-temperature smoldering combustion in the appliance. These low temperatures favor the production of a larger proportion of tars. Chimneys serving appliances which are frequently burned in an air-limited mode are more likely to collect both condensable hydrocarbons and tars.

Both the condensation and contact sticking of creosote are aggravated by a long smoke *residence time* – the actual time that the smoke takes to travel from the bottom to the top of the venting system. The amount of gases that will condense on a given surface is a function of time, as is the number of solid or liquid particles that will randomly contact flue surfaces. Flue gases will also cool as a function of time, resulting in cooler flue surfaces higher in the chimney. Slow-moving flue gases may also allow solid particles, particularly the larger carbon chains and clumps, to “fall out” of the smoke stream and settle on nearby surfaces. All things being equal, the length of time that smoke lingers in the venting system is directly related to the amount that will remain as creosote.

Residence time is a function of the cross-sectional area (actually the total volume, including the height) of the venting system and the flue gas flow rate. The flow rate in turn is influenced by the appliance operating mode. If little air is allowed *into* a stove, little smoke can flow *out of* the stove and into the venting system. By

contrast, an open fireplace handles large volumes of air and thus a large flue gas flow rate. The least favorable situation, from the standpoint of creosote buildup, is an air-limited appliance (such as a stove) connected to a large-dimensioned venting system (e.g., a fireplace chimney).⁴

Finally, *turbulence* in the venting system enhances cooling of the flue gases and of the flue walls above and brings more solid and liquid particles into contact with internal surfaces. Elbows in chimney connectors and offsets and changes in size and shape of the chimney passageways are common sources of turbulence. More subtle is the effect of projections such as mortar fins into the flue as well as rough flue surfaces, including previous deposits of creosote.

As initially deposited, the form of creosote reflects the part of the smoke from which it came. Condensable hydrocarbon gases will produce an oily and sometimes runny liquid ranging from a thin brown tint to dense black. Tars will be tarry – usually dense viscous semi-solid and uniformly black. Soot will appear soft, and dusty or velvety, and is usually brown or black. Commonly, both water and fly ash are mixed with these forms and can affect their behavior. The source of water is the H₂O produced by combustion and condensed under the same conditions as the hydrocarbons as well as any that may be delivered from the fuel. The water may make the oils and tars sufficiently liquid to seep through openings in the venting system such as stovepipe joints or cracks in flue liners. *Although the water eventually evaporates and leaves the creosote behind, the temporary “mobility” it gives to the deposits can affect the safety and integrity of the venting system.*

2.2.3 CREOSOTE TRANSFORMATION

The form in which it is deposited is not necessarily the form in which creosote is found in actual chimneys. The deposits can and usually do go through a variety of transformations as a result of ongoing and subsequent use of the chimney. Figure 2-1 illustrates the steps in creosote production and transformation.

Particularly during the early stages of a new wood fire before the walls of the venting system have been warmed up, water is likely to condense along with the hydrocarbon components of creosote.

Usually later stages of a fire will send enough heat into the chimney to evaporate all or most of the

water. Even without significant heat, most water will eventually evaporate, and deposits found in chimneys usually contain relatively little actual water. The creosote left behind contains most of the originally-deposited hydrocarbon tars and oils and is most commonly referred to as *tar glaze*.

Tar glaze is a shiny, smooth-surfaced, uniformly black deposit. Although it is composed primarily of wood tars, it can still contain many of the hydrocarbon liquids deposited by condensation. It can have an oily feel and have a very pungent odor from the ongoing evaporation of the more volatile hydrocarbons. Tar glaze is normally sufficiently viscous to stay in place and not run or flow at ambient temperatures. When found in this form in a chimney, tar glaze creosote is very resistant to mechanical cleaning. It may need to be literally dissolved by strong chemicals used only by professional chimney service technicians.

If sufficient heat continues to be available in the chimney, the liquid components of tar glaze will be gradually evaporated. The degree of evaporation depends on the exposure temperature, the composition and density of the gases flowing past the creosote, and the vapor pressure of the particular compounds in the glaze. The process

may produce bubbles of evaporating gases under the flexible skin of the tar. As the evaporation process continues, the tar becomes increasingly viscous and eventually hard. The resulting form can be referred to as “slag.”

Creosote slag is composed of wood tar without its more volatile components. It may be very dense or suffused with bubbles or pores from the evaporation of gases. Its primary characteristic is its hardness and brittleness. It is usually resistant to normal brush cleaning, but, owing to its brittleness, it can often be knocked off the flue wall with the specialized impact devices or scrapers used by professionals.

If the chimney interior is exposed to higher temperatures, both tar glaze and slag will begin to pyrolyze – the same process which created the creosote from wood. In contrast to evaporation, pyrolysis is characterized by the actual breakdown of the compounds which form the creosote. Just as with wood, the products of creosote pyrolysis are gaseous and will create bubbles and pores in the deposit. As the process continues, the creosote will become progressively drier, more brittle, and less dense. *As with wood, the pyrolysis process drives off fuel. Should the resulting gases ignite,*

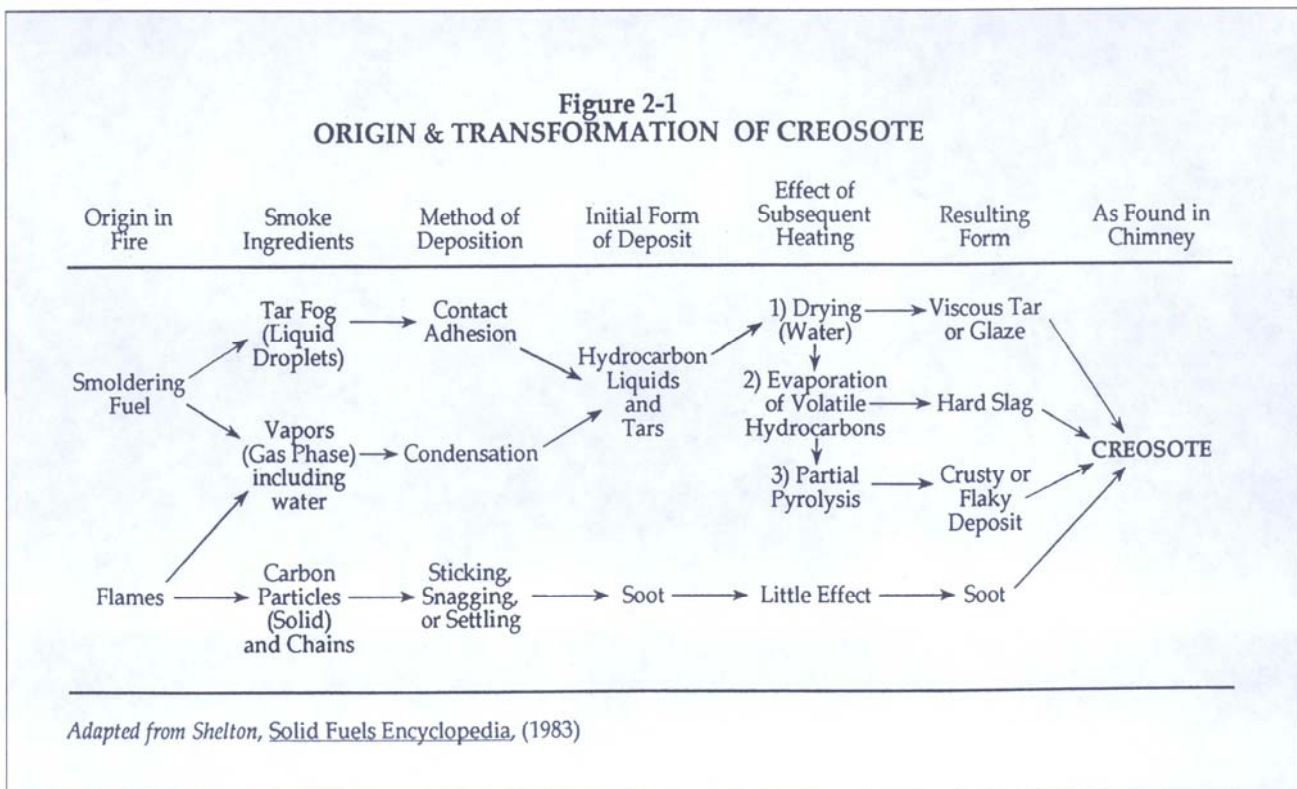

they will burn as flames and release substantial energy. Theoretically, the solid deposit left could be fully pyrolyzed to noncombustible ash. In practice, even crusty creosote deposits retain sufficient carbon and hydrocarbons to support combustion.

Well-pyrolyzed deposits are crusty or flaky and readily fall apart into granules and chunks when disturbed. Pyrolyzed creosote is readily swept by brushing, and flakes will often fall off of their own accord and drop to the bottom of the chimney. However, this crusty deposit also acts as an insulator and may prevent sufficient heat from reaching underlying deposits of tar glaze. It is not unusual for brush cleaning to reveal a resistant layer of glaze that must be dealt with separately.

Since soot is composed primarily of molecular carbon, it does not pyrolyze and is not usually affected by moderate levels of heat in the chimney.

Obviously, all of these transformations do not necessarily take place throughout any given chimney, nor do they necessarily take place as separate distinct phases. Typically, the deposits will be undergoing different degrees of each stage concurrently, and the processes will progress differently at different locations in the chimney. Often creosote is deposited and modified in a cycle that conforms to the operating cycles of the appliance. Tarry or liquid deposits may accumulate during long smoldering cycles but be dried and pyrolyzed by subsequent more active fires. While it is not uncommon to find a chimney fully coated with tar glaze or with nothing but soot or crusty deposit, the typical wood-burning stove-connected chimney contains samples of all forms.

The nature and form of the deposits present will affect the ignition and behavior of a chimney fire should one occur. This will be more fully discussed in section 2.3 below.

2.3 CHIMNEY FIRES: GENERAL DESCRIPTION

As with fires involving the structure of a building, there is no single scenario that describes the ignition, spread, and behavior of chimney fires. They can vary widely in ease and means of ignition, intensity and duration, and in after-effects. Since fires in general, and chimney fires

in particular, are an inherently disorderly phenomenon, an organized description of their behavior will always be inadequate.

Some generalizations are possible, however, based on the reports of those who have experienced them. The direct observations of homeowners, firefighters, and chimney sweeps have a kind of inherent validity that no amount of theoretical analysis can duplicate. They can be used to build a general characterization of chimney fires and, to some extent, to reach conclusions about the causes of the effects. Fortunately, laboratory researchers are also among those who have experienced chimney fires. Their observations help confirm and extend the information from the field.

The information about the behavior of chimney fires presented here is developed from fires in both factory-built and masonry chimneys. Although the different environments may produce somewhat different effects, most of what follows is probably relevant to fires in both types of equipment. When there may be significant differences for masonry chimneys, the differences are addressed separately.

2.3.1 IGNITION OF CREOSOTE

The ignition of a creosote chimney fire can be quite difficult or surprisingly easy. From the high incidence of reported fires (and higher incidence of unreported fires), it is clear that many people have either accidentally or intentionally discovered the proper technique. Given the number of wood-burning units in use, it is also equally true that many people manage to avoid a fire by luck or by design.

Most chimney fires begin as a result of a period of overfiring or at least hotter-than-normal operation of the connected appliance. Typically, the operator reports having burned a large amount of paper or kindling immediately before the fire. Undoubtedly, a large percentage of chimney fires are ignited by direct contact of flames issuing from the appliance onto deposits of creosote, but there is no particular reason that *flames* (which are simply very hot gases and particles) are necessary for ignition. It is likely that non-burning flue gases hot enough to raise the creosote to its ignition temperature can be the source of fires. It is also reported that sparks or embers carried from the appliance have settled on creosote deposits and started fires.

It is not even necessary that operation of the appliance be severely abnormal. Creosote can be deposited on surfaces of chimney connectors very close to the flue outlet of the stove, particularly during periods of smoldering operation. Normally, such deposits will be dried, baked, and pyrolyzed by subsequent operating temperatures. Under the right conditions, all the combustible fractions can be driven off, and the deposits may be reduced to noncombustible ash. During this process, however, they could be ignited by a relatively minor episode of high temperature. Under the right conditions, this incipient chimney fire can spread through the connector to the chimney and ignite more substantial deposits.

Usually the presence of a chimney fire is immediately apparent (see the phenomena discussed in section 2.3.2). Occasionally, however, a homeowner will report a delay between the period of overfiring and the onset of obvious signs of fire. It is likely that deposits are in fact, burning in the venting system but lack the sufficiently volatile fuel, oxygen supply, or combustion zone temperatures needed to support rapid burning. As will be discussed in section 2.3.3, this effect may be a factor in chimney fires which are not detected at all during their occurrence.

The conditions needed for ignition of a chimney fire are essentially the same as those necessary to start any fire – adequate fuel, heat, and oxygen. Chimney fires are ignited when these elements come together in a favorable combination. A fire is avoided when one or more is deficient. The manner in which these factors are manifested in a chimney is unique and is worth examining.

Fuel

There is no absolute minimum of creosote accumulation necessary for a chimney fire. The amount of creosote present will affect the severity and duration of a fire but not its likelihood of ignition. In this sense, the purpose of regular chimney sweeping is not to prevent the occurrence of a fire but to limit its severity and effects should one occur. Creosote buildup begins with the renewed use of the chimney after sweeping, and thus the possibility of fire almost always exists.

Significant chimney fires have been reported within a week of sweeping the flue. In one study² of chimney related fires, about 14 percent of homeowners reported that the chimney had been

swept within the previous month. A total of about 30 percent claimed sweeping within the past five months. Not all of these fires were necessarily creosote chimney fires, and, as the researchers point out, both the adequacy of the sweeping and the credibility of the homeowner's claim are open to question. *Nevertheless, it is clear that sweeping alone does not prevent chimney fires. It can usually be assumed that sufficient fuel is present to support some degree of fire.*

The *location* and *type* of creosote can influence the likelihood of ignition. Since the appliance is usually the source of heat of ignition, creosote located lower in the venting system is more likely to reach the necessary temperature. As discussed in section 2.1, the location of deposits depends on the composition of the effluent from the appliance and the details of the venting system design. In some systems, the conditions are favorable for accumulation only toward the top of the chimney. It is thus possible to have significant fuel present somewhere in the chimney but far enough from the heat source to avoid ignition.

Different types of creosote are known to ignite more readily than others. Unfortunately, there has been no published laboratory analysis of the ignition characteristics of different forms. As discussed below, no ignition temperature for creosote in general has been determined. The differences in ease of ignition probably relate to the relative volatility and density of the different deposits.

When heat is suddenly applied to the denser forms of tar glaze and slag, they begin to pyrolyze and absorb energy. If sufficient heat remains present, the gases liberated by pyrolysis may be ignited, causing a chimney fire, but brief exposure of tarry deposits to heat may not be adequate to result in ignition. Fluffy or crusty deposits, on the other hand, may reach their ignition temperature more easily during a brief exposure to heat, just as it is easier to ignite a single magazine page than a whole closed magazine. The heat released by this initial glowing combustion of solid material may be sufficient to then ignite the volatile material.

The ignition of the gases given off by creosote pyrolysis is also more dependent upon the concentration of available oxygen. Unless the oxygen/gas mixture is within the limits of flammability for the particular material, it will not ignite regardless of temperature. Solid deposits,

especially those primarily of carbon, are less dependent upon particular oxygen content and can ignite and begin releasing heat at lower concentrations.

It is also plausible (though it has not been specifically investigated) that soot has a lower ignition temperature than the more complex forms of creosote. It has been well-documented⁹ that the solid material left behind by the pyrolysis of wood has a significantly lower ignition temperature, ranging from 200 to 250°F, than the wood itself. This material is called charcoal when found in a wood fire and pyrophoric carbon when found in structural components exposed to long-term heating. It is possible that the form of carbon known as chimney soot, the origin of which is the pyrolysis of wood or wood creosote, has similar characteristics.

Temperature

Owing to the complexity and variability of chimney creosote, no particular ignition temperature has been determined, and most researchers are reluctant to speculate on even a mean value. The situation is complicated by the fact that the term ignition temperature can mean many things, depending on the conditions being described. The *ignition temperature* generally cited for solid materials is a *non-piloted* or *spontaneous* ignition temperature. This refers to the temperature to which material would need to be raised in order to begin self-sustaining combustion without being exposed to a flame. On the other hand, the ignition temperature cited for liquids often refers to the temperature at which the material will give off sufficient gases to be ignited by a pilot flame held close to the material. This “piloted ignition temperature” is more correctly known as the *flash point* (the temperature at which the gases will flash but not keep burning) and the *fire point* (the temperature at which self-sustaining combustion will occur above the liquid).

The creosote deposited in chimneys can behave like either a solid or a liquid, depending on the mix of material and the conditions of exposure. It is therefore difficult to even determine which type of ignition temperature is most appropriate for creosote. Furthermore, the conditions within a chimney at the inception of a chimney fire are so variable and disorderly that any attempt to derive a single meaningful “ignition temperature” is probably futile. With all these cautions in mind,

we can discuss the information that is available on the thermal conditions needed for creosote ignition.

The most credible estimate of creosote ignition temperature available in the scientific literature on chimney fires is by Stone¹⁰, who suggests a working figure of 1000°F, plus or minus 200 degrees. This figure would be consistent with that usually quoted for the ignition of the combustible gases in a wood fire (~1000°F) which are the source of creosote. Furthermore, it is likely that many chimney fires begin with the ignition of gases given off by the pyrolysis of creosote, so it is plausible that their ignition temperature is similar to that of the gases produced by the pyrolysis of wood. As discussed above, however, the actual temperature needed in a chimney may depend on the type of deposit and on the duration of exposure. It would not be surprising to see lower ignition temperatures documented for some forms of creosote.

As Stone points out, the ignition temperature cited is for the fuel itself, not the flue gas temperature needed to ignite it. The flue gas temperature needed to raise creosote to its ignition temperature will depend on the heat loss characteristics of the vent system environment. A well-insulated environment, such as the flue of a solid-pack type factory-built chimney, will minimize heat loss from the creosote and encourage it to reach a higher temperature more quickly. At the other extreme, a poorly insulated component, such as a single wall stovepipe, may not allow retention of sufficient heat to result in ignition. Although it is probably rare in the field, Stone reported ignition of a chimney fire in an insulated flue without ignition of deposits in the attached connector.

The thermal characteristics of masonry chimneys probably fall somewhere in between insulated factory-built chimneys and uninsulated stovepipe. Most masonry chimneys are not well-insulated, and those located on the exterior of a heated structure will present a relatively cool environment. Their high mass and thermal inertia will inhibit rapid temperature rise from a brief application of heat. On the other hand, it is not necessary that the whole chimney be heated to the creosote ignition temperature. The creosote itself, particularly less dense forms, will offer significant insulation. Therefore, the flue gas temperature needed to ignite the surface layers of creosote in a masonry chimney may not be much different than

that of a factory-built chimney.

At any rate, Stone estimates an actual gas temperature of 1200-1300°F is needed to ignite deposits in a well insulated environment. From a larger series of chimney fires in a variety of chimney types, Peacock¹¹ reports flue gas temperatures at the stove outlet of 1170-1300°F before ignition of a chimney fire was clearly evident. In both studies, however, overfiring of the appliance was continued until a chimney fire was well established. It is possible that limited areas of creosote had ignited earlier and possibly at lower temperatures, but their presence was masked by the large fire in the stove. Had the stove fires been allowed to die down before the chimney fire was obvious, it is possible that such an incipient fire could have spread and become established without the contribution of such high temperatures from the stove.

The temperature cited by Stone and others appears to refer only to ignition of creosote by hot *gases*. In effect, this is non-piloted or spontaneous ignition temperature. It does not account for the fact that creosote deposits may be bathed in *flames* and that a piloted ignition temperature may be of more importance. A material generally does not need to be heated to its spontaneous ignition temperature in order to give off gases which could be ignited by a flame.

In an experiment conducted for this report, samples of actual tar glaze creosote were removed from a chimney flue and formed into flat cakes with a thermocouple junction embedded. The specimens were then subjected to the procedure used for the flash point testing of liquids, using the Cleveland open cup apparatus.¹² Upon heating, the creosote began to melt to a viscous semi-liquid at temperatures below 200°F and began to bubble and expand between 200 and 250°F. The gases given off did not form a consistent cloud above the sample, but piloted ignition with a sustained flame occurred when the interior temperature of the creosote was as low as 305°F and as high as 375°F. These results suggest that, with some forms of creosote under some conditions, ignition can occur when the temperature of the creosote itself is substantially below 1000°F. A self-sustaining chimney fire can occur if the material is heated to this temperature and flames are present to ignite the resulting gases.

From examination of the accounts given by people

who have experienced chimney fires in the field, it seems likely that flue gas temperatures in excess of 1000°F are certainly not always necessary to begin a chimney fire. There have been enough reports of fire following periods of essentially normal operation that their significance cannot be ignored. It may be that the actual ignition temperature of creosote, or some forms of it, is substantially lower than is apparent from the limited laboratory testing above. It is also conceivable that moderately elevated temperatures for a sufficient period of *time* can lead to something akin to “spontaneous ignition” of creosote. It is also possible that in some systems creosote can suddenly flow or drop into or near the stove, and the fire can spread from there. At any rate, the reasons for such “undeserved” fires are at this point speculative and await further investigation.

Availability Of Oxygen

Even when it is brought up to the range of its ignition temperature, creosote does not always ignite. As with any fuel, sufficient oxygen must be available to stimulate ignition and support continued combustion. This fact has undoubtedly saved many homeowners from unintended chimney fires and has also frustrated researchers attempting to ignite fires for study.

Assuming that the venting system is constructed reasonably well, the major source of the oxygen present in most chimneys will be the air drawn in through the doors, air inlets, or other openings in the appliance. In order to reach the chimney, such oxygen must get past the fire without being consumed. Under the conditions in which most chimney fires start, i.e., a large fire in the appliance, much of the oxygen is in fact used up. Without a substantial source of additional air, such as a leaky cleanout door or poor stovepipe joints, creosote may simply pyrolyze without ever igniting.

In his initial study of chimney fires,³ Shelton showed the importance of this effect. While attempting to ignite chimney deposits with a large wood fire, he measured oxygen concentrations in the flue gas at the stove outlet as low as one percent – too low to support significant combustion. Much of the creosote in the chimney was pyrolyzed away, losing much of its potential energy before a noticeable flue fire occurred. Shelton found it necessary to make explicit efforts

to provide additional air in order to produce usable results from future fires.

Peacock had similar difficulty with one test chimney.¹¹ A fire was successfully ignited in the chimney connector but did not spread to the vertical flue although temperatures were high. When the cleanout was opened, it was discovered that fallen creosote had blocked the flue gas flow. The fallen creosote was preventing aspiration of the air needed to support a full-blown fire by inhibiting the flow of gases through the flue. With the blockage removed and ample air being supplied from the open cleanout, an extremely intense chimney fire ensued.

Oxygen supply is not usually so problematic, however, since many chimney fires, both in the field and the laboratory, have been successfully ignited by a high fire in the appliance. Most real-world venting systems are sufficiently leaky that a chimney fire would not be completely prevented or extinguished by eliminating the oxygen supply from the appliance. The minimum amount of oxygen needed for ignition is at least partially dependent on the type of creosote fuel. Some types may ignite and burn, though not energetically, at low oxygen concentrations. They may “hold the fire” until more oxygen becomes available, at which point the fire may flare into recognizable proportions.

In summary, the conditions needed for ignition of a creosote chimney fire are not particularly difficult to achieve. Two of the essential ingredients, adequate fuel and oxygen, are probably present during most phases of operation although oxygen may become limited during high fire operation. The biggest variable, and source of variability, is the temperature needed for ignition. It would seem that temperatures which clearly represent overfire conditions are often needed for ignition, and a period of high fire is most commonly associated with the initiation of real-world fires. However, there also appear to be conditions, perhaps related to the type of creosote present or its location, under which fires are started by less extreme operation.

Although not necessarily universally applicable, flue gas outlet temperatures above 700-800°F should be avoided to limit the possibility of ignition of creosote. Regular sweeping of the venting system will not necessarily prevent a fire but will at least limit its severity. Efforts to ensure

a reasonably air-tight venting system may occasionally prevent ignition of a fire that would have occurred otherwise and may be essential for limiting or extinguishing a fire should one ignite.

2.3.2 “FREE-BURNING” CHIMNEY FIRES

The literature on chimney fires especially that directed at consumers is full of dramatic metaphors for the sights and sounds of a chimney fire. They are compared to “a freight train running through the living room” or “a jet plane landing on the roof,” and invariably describe “flames and embers shooting from the top of the chimney like a Roman candle.” As discussed immediately below, these are useful but not always accurate descriptions of one type of chimney fire which we will refer to as “free-burning” or “classic” chimney fires. However, many chimney fires do not conform to this model. Not all fires will exhibit all of the classic phenomena, and many are so slow in developing that they do not manifest any of the usual outward signs. These less-obvious fires will be discussed separately in section 2.3.3.

External Signs

Whatever the conditions of ignition, the presence of a free-burning chimney fire is often unmistakable. Most fires, even those out in the open, produce certain recognizable phenomena. The volatile nature of creosote as a fuel and the geometry of venting systems intensify both the fire and its signs, making chimney fires distinctly unnerving events. One of the most often-studied effects that intensifies building fires is the so-called “chimney effect.” It is all the more dramatic when the structure is a chimney!

The first external signs of a chimney fire are usually aural – a noisy inrush of air resulting from the very high draft created by extremely high flue gas temperatures. Those who have experienced it compare the sound to the roar of a jet plane taking off or a train rumbling through the dwelling. At least some of this sound stems from the effects of velocity as air is pulled in through the small orifices in the appliance and venting system. The lower sounds may reflect the resonance of pressure waves caused by the ignition and extinction of flames amplified by the tubular chimney flue.

Certain sounds associated with expansion and strain release can usually be heard as well. A

ticking or tinkling sound can often be heard over the sound of quieter fires. These are due to the expansion of metal parts of stove and chimney connector and to falling flakes of creosote. Often there is a louder crackling sound similar to that heard in a wood fire. This is the result of expansion and pyrolysis of the creosote. It is not unusual to hear a loud report from the sudden failure of chimney liners, bricks or other components of the venting system. Stovepipes will often vibrate and may glow red hot opposite patches of intensely burning creosote. If the joints between stovepipe sections are not perfectly tight, flames are sometimes visible through the gap.

One of the more dramatic and potentially dangerous effects of some chimney fires is back-puffing of smoke and sometimes flames from the appliance or venting system. This effect is caused by a series of rhythmic explosions of fuel-rich creosote gases in the confined area of the flue. As the gases burn, they may consume the available oxygen faster than it is supplied. When the concentration of oxygen in the gases reaches the lower limit of flammability, the flame is extinguished, but plenty of heat remains in the flue. Air will re-enter the flue and mix with the gases which then ignite suddenly and explosively. The result is immediate high pressure in the chimney which cannot be fully relieved out the top and smoke and flames may be driven through any opening in the flue or appliance. As the oxygen is again quickly depleted and flames are extinguished, the pressure drops suddenly, drawing in more air to initiate the next explosion. This cycle may be repeated several times a second.

If the flue becomes blocked by fallen or expanded creosote during the fire, a large volume of smoke may spill back into the dwelling. Although the blockage will limit flue gas flow and reduce the air available to sustain the fire, the heat retained in the flue will continue to pyrolyze the creosote (which is the source of the smoke) for some time. Rather severe smoke damage to the building and contents has been known to result from chimney fires of this nature.

The outdoor signs of a chimney fire can be equally dramatic. Almost without fail, a large volume of dense dark or black smoke will come out the top of the chimney. Sparks or embers of glowing creosote material may be drawn up by the strong draft and expelled from the chimney top. Less

frequently, actual flame may be visible above the chimney top. The gases in the upper portions of a chimney may be oxygen-poor and below their ignition temperature. Even when exposed to air above the chimney, chimney fire smoke may not burn without a pilot source of ignition. While a torch-like flame at the top of the chimney may be one of the hallmarks of chimney fire lore, it does not follow that external flaming must accompany even a severe fire inside the chimney.

As the chimney itself is heated by the fire, steam may be seen escaping from cracks, mortar joints, or even through the chimney material. Axial thermal expansion of the chimney liner can be significant - as much as one inch for a 25 foot liner at an average 1000°F temperature rise.¹³ If the liner is not anchored to the chimney crown, the tile may protrude this additional length above the top. If the tile is anchored, as is more common, the expansion may actually lift the crown or several courses of brick above the rest of the chimney. Typically, gaps or cracks may develop at one or more horizontal bed joints between masonry units during a chimney fire of sufficient duration to heat up the chimney.

Progression

What is going on inside the chimney is at least as interesting as the external phenomena. A newly-ignited chimney fire does not engulf the entire chimney at once; in fact, it is likely that there is no point where the full length of the flue is on fire. The development and travel of chimney fires has not been fully studied, but several researchers have made observations that shed light on their behavior and aftereffects.

The nature and amount of the creosote fuel will obviously affect the nature of the fire. The amount of deposit will be the primary determinant of the duration of the fire unless it is extinguished before the fuel is exhausted. The intensity of the fire will be a function of the amount and type of creosote as well as the oxygen supply and the heat transfer characteristics of the system.

Because true soot is essentially pure carbon, it cannot burn with a flame. Instead, it will glow much like charcoal. Fires that involve nothing but soot are undoubtedly less dramatic than the classic chimney fire just described. Because they do not produce flames, they may not produce flue gas temperatures as high as does the more volatile creosote. However, burning on the surface of the

flue can be quite intense and affect the chimney structure as significantly as do flaming fires. Before the resurgence of wood burning, chimney fires earlier in this century usually involved burning coal soot, and the fire safety literature was full of cautions about potential damage to the chimney and building structure.

Most chimney fires involve creosote that began as tar glaze and has been pyrolyzed to some degree prior to the fire. Because they usually still contain significant volatile matter, they have the potential for burning with a flame. Thus the combustion of creosote in a chimney is similar to combustion of wood in an appliance and includes many of the same complexities.

When the creosote is heated in a fire, pyrolysis produces gases which, as with wood, are the source of flaming combustion. With wood, these gases find their way through the porous structure of the wood to the combustion zone. With the viscous tarry forms of creosote, however, there are no pores. The gases developed within the substance will create bubbles under the flexible surface. This process goes on even during the slow pyrolysis under moderate heating in a chimney without a fire. During a chimney fire, however, the production of gases is rapid, and the creosote will literally foam and expand greatly in volume. This effect is important for recognizing the after-effects of a chimney fire and will be explored more fully in section 2.5.

The flames generated by the pyrolysis of creosote will essentially fill the cross-section of the flue unless the fuel is virtually depleted or the flue is very large. Since the primary source of oxygen to sustain the fire is through the appliance and any leakage in the lower parts of the system, oxygen will be most available below the fire. The fire itself will consume most or all of the available oxygen. In most fires, the rate of propagation of combustible gases is probably far in excess of the oxygen available to burn them. As a result, the fire will produce a large volume of unburned smoke (as with an air-limited wood fire), and the flue gas mixture above the flame will be, at best, oxygen-poor. The heat generated by the fire and carried up the flue will aggressively volatilize and pyrolyze the deposits higher up, resulting in the production of even more smoke. Above the zone of active combustion, there may be sufficient heat to propagate the fire but insufficient oxygen.

The progress of a chimney fire can thus be characterized as a traveling flame front. Beginning at the bottom of the venting system (or wherever the point of ignition was) it will consume the volatile components of the fuel and begin the pyrolysis of the products above. As the gaseous phase of combustion is completed, the flame will move up the flue and ignite successively higher deposits until, theoretically, the fuel is exhausted at the top. The fire below the flaming zone is not necessarily out since the solid products of charred creosote can still burn, as does the charcoal left behind by a wood fire. On the other hand, the creosote in the higher reaches of the chimney, having been well-pyrolyzed by the fire below, may not burn with the same intensity once the fire reaches it.

By instrumenting a chimney with thermocouples throughout its length, Stone was able to show that existence and progress of this flame front.¹⁰ As the chimney fire was ignited, the flue gas temperature at the appliance outlet was the hottest point in the system. After a few minutes, the next thermocouple up showed a higher temperature, indicating that creosote was burning in the chimney. After a while, the temperature at this couple declined slightly, and the next highest measuring point succeeded as the hottest location. This process continued more or less distinctly until the fire died down and all temperatures began to decline.

The same effect was observed by Shelton³ in most of his fires. However, in one test there were a number of peaks and valleys at different height locations and some evidence of downward propagation. It is possible that this irregular behavior resulted from temporary partial blockage of the flue or from burning liquid creosote flowing back down to lower sections.

Figure 2-2 shows a schematic plot of the temperature curves recorded by Stone and Shelton. This representation does not show the actual time/temperature data which were nowhere near as smooth as the curves shown. Instead, it shows the general shapes and relationships among the temperature profiles for the various chimney heights. The actual temperatures observed during a variety of laboratory chimney fires will be discussed more fully in section 2.4.

Flink has put forth a different, though not necessarily inconsistent, theory of the progression

of chimney fires.¹⁴ According to his observations, thin layers of creosote appear to burn off successively. After a layer has been consumed from bottom to top, a secondary fire again starts at the bottom and burns upward, consuming another layer. Up to four secondary burns were observed in laboratory chimney fires. Details of this test structure and procedure have not been published, so it is unclear what factors might have influenced this behavior. Since the heat from a fire can penetrate deeply into creosote, it seems unlikely that pyrolysis would be limited to just the surface layers, and no reason is given for why re-ignition of the bottom awaits completion of burning at the top. Still, peaks and valleys of intensity have been recorded in other laboratory fires, so it is possible that something like this phenomenon occurs although probably not in so orderly a fashion.

Chimney fires are not organized, obedient events, so there is probably no fire that exactly follows any tidy characterization. Moderate fires have been observed to crawl up one side of the flue without burning the other sides. Leaks of air through cracks or joints between liners may allow a combustion zone above the main flame front. Chimney fires sometimes flame intermittently at the top as the air flows and fuel gas concentrations vary. There have even been fires where the evidence suggests that the fire was limited to the top. However, the theory of a traveling flame front helps explain many of the observed temperature dynamics and thermal gradients and their impact on damage to the chimney and house structure.

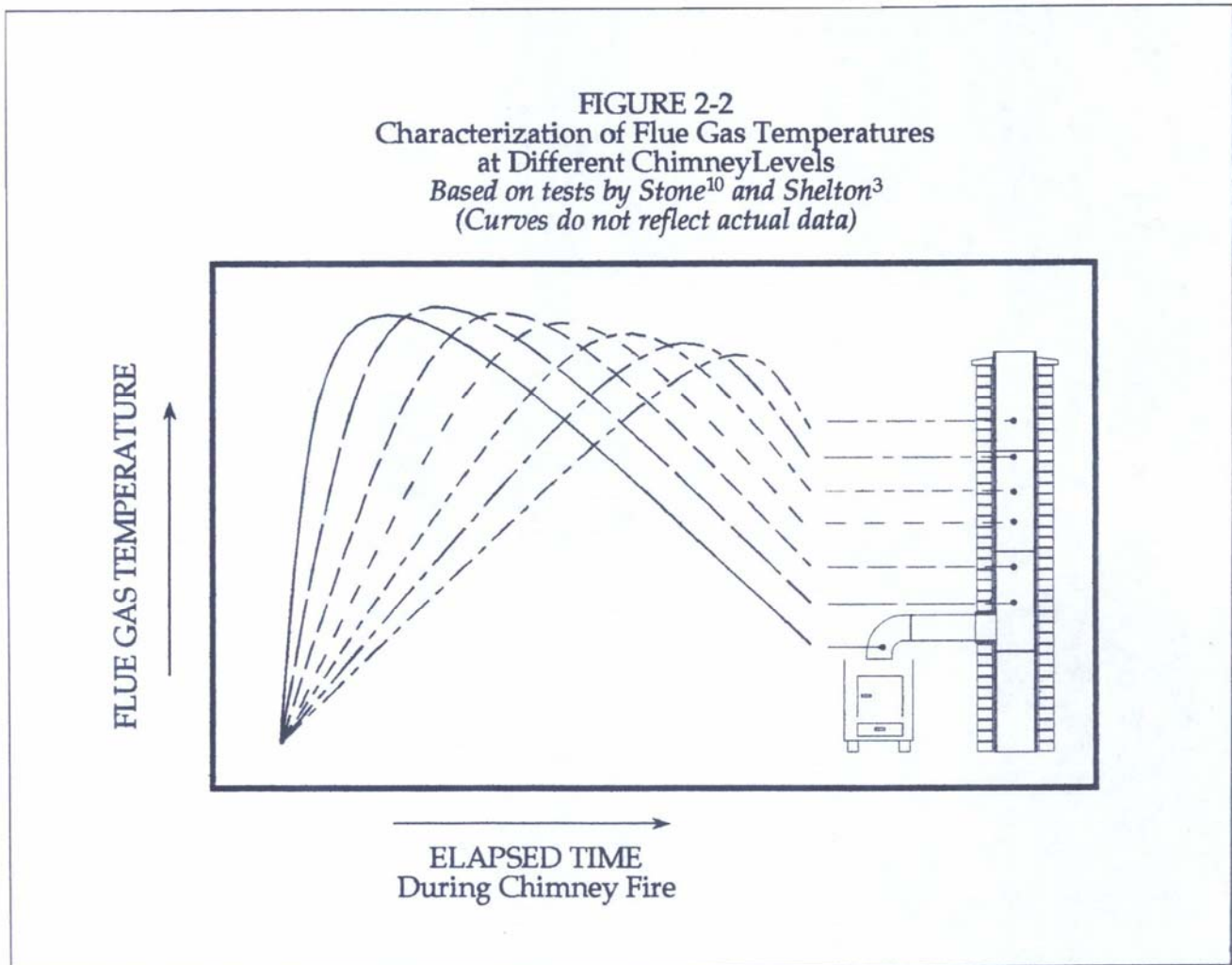

Surprisingly, there have been no published estimates of the mass burning rate or rate of heat release of creosote during chimney fires. Most researchers tracked the duration of the fire and temperature profiles, and some present estimates of the amount of creosote present before and after the fire have been made. None of the studies puts forth information that directly addresses heat evolution as a function of time or mass.

Stone¹⁰ measured the progress of the flame front (as indicated by peak temperatures) up the chimney at 26.7 inches per minute for a free-burning fire, and 13 inches per minute for a slow, air-limited fire. These represent only two fires, and measurements of the amount of creosote were not made. Shelton³ carefully measured the weight of creosote in the chimney before and after the fires, but durations of the fires were not reported. Peacock¹¹ observed the range of thickness of deposits in the test chimneys, and these seem to correlate to some extent with the intensities and durations reported. Again, weight or weight loss is not reported.

There are probably wide differences in heating value between different forms of creosote. Soot, as a form of carbon, may have a heat of combustion similar to charcoal – 13,000 to 14,000 BTU/lb. Some of the chemicals which are presumed to be part of creosote have heats of combustion as high as 18,000 BTU/lb, but these tend to be the more volatile hydrocarbons and more likely to be driven off by heating prior to a creosote fire. A *very* tentative estimate would place an average gross heat of combustion for an “average” sample of chimney creosote somewhere between 12,000 and 15,000 BTU/lb. Combustion of creosote in a chimney fire is clearly not close to complete, and a large proportion of this potential chemical energy is never released. Perhaps the most accurate generalization that can be made, until further information is produced, is that chimney fires can release an extreme and unusual amount of heat in a short period of time and can cause sudden and intense heating of the chimney structure.

2.3.3 “SLOW” CHIMNEY FIRES

The descriptions presented in the previous section are for a “classic” chimney fire – one that conforms to the abundant folklore on the subject. Such fires should more accurately be designated *free-burning* chimney fires since they burn with a

generous supply of oxygen and are limited only by the amount of air they can pull in. Such fires do happen and they give rise to the standard descriptions often used to represent all chimney fires. Just as all structure fires are not free-burning, neither are all chimney fires.

“Slow,” or “limited” chimney fires appear to fall into two categories – those that result from partially successful attempts to extinguish the fire and those that never become obvious and are not detected during their occurrence. Both deserve the status of “chimney fires” because they involve burning of combustible deposits in the venting system, and, though less exciting, both can be as damaging and dangerous as free-burning fires.

The standard advice given to homeowners, should they have a chimney fire, is to close the air controls on the appliance and any other sources of entry into the system. The idea is to deprive the fire of one of its essential elements: oxygen. Theoretically, this should result in an immediate halt to combustion. In practice, it rarely does. Even most “airtight” stoves are not fully air tight nor are joints between stovepipes, fireplace insert cover panels, or cleanout doors. The combined leakage of such small sources will usually permit sufficient air flow to support combustion at some level.

Unless the system is unusually leaky, the closing of obvious openings will stop most of the flaming combustion in the chimney. Much of the heat generated by the fire will be retained, at least temporarily, in the chimney and will carry forward the pyrolysis of the creosote. Glowing combustion of pyrolyzed creosote will continue, being supported by the limited available air flow. Depending on the amount of glowing, sufficient heat may be released to continue pyrolysis of unburned creosote although the gases may not ignite. Creosote can continue to smolder in this manner for hours and can eventually travel through the whole length of the chimney.

With the elimination of flaming combustion, most of the obvious signs of a chimney fire decrease or disappear. Because air flow into and through the system is limited, the roaring noises and expulsion of sparks or flames from the chimney top will stop. Smoke from the chimney top may decrease significantly because pyrolysis of the creosote is taking place much less rapidly. The crackling of burning creosote may still be evident, but its

significance may not be appreciated. Many homeowners (and some fire fighters) have assumed that the fire was out and have opened the stove doors or cleanout. If sufficient heat is still present in the chimney, the fire may be rejuvenated by the renewed air flow.

One should not conclude from this discussion that closing the air inlets to a chimney is not a good response to a chimney fire. As discussed in section 2.3.4, reduction of oxygen is at least part of a successful strategy for extinguishing a fire, but a chimney fire is not defined by its flaming phase. A reduced, air-limited fire is still a fire and may represent a greater danger, in some respects, than a free-burning fire.

There is substantial field evidence and some laboratory evidence that chimney fires can ignite and progress without ever developing the obvious signs associated with a free-burning fire. The reasons for and conditions necessary for such hidden fires are not well understood, partly because they may not be detected and observed while they are happening. Undoubtedly, they are related to the limiting but not total elimination of one or more of the vital elements of a fire: fuel, oxygen, or heat.

The effect of limiting oxygen has already been discussed in the context of reducing an already well-developed fire. There is no particular reason why this effect should be restricted to cases where the operator intentionally reduced the air supply to a known chimney fire. As discussed in the section on the ignition of chimney fires, deposits can ignite during periods of moderate overfiring and not develop immediately into an obvious fire. Many people start a new load of wood by "burning it hot" for a period of time and then closing the stove air controls to achieve a desired level of heat output. It is not unreasonable to expect that this procedure sometimes ignites deposits which, though air-limited, will support progressive smoldering combustion in the chimney. This would also explain the experience of homeowners who report that a chimney fire suddenly ignited after the stove doors were opened without a high fire. In fact, creosote may have been smoldering for some time, generating heat and lacking only a supply of oxygen to develop into a full-blown fire.

Even where air is available, the type or distribution of fuel may not be conducive to the

development of an obvious fire. Soot cannot burn with flames, and crustier forms of pyrolyzed tar may generate only moderate flaming even when burning at their maximum intensity. Thin or patchy deposits of creosote may burn energetically, but the fire may be so localized that it doesn't become recognizable as a chimney fire.

The heat transfer characteristics of masonry chimneys are probably a major factor in some undetected fires. In order for a fire to become intense, it must generate sufficient heat to propagate the fire, and a large proportion of the heat must be retained in the combustion zone. The low insulating ability, high thermal mass, and large flue area of many masonry chimneys create a less than ideal combustion zone. Unless the heat supplied to ignite the fire was substantial enough to start widespread energetic combustion, an incipient chimney fire may never build enough heat to become free-burning. A large percentage of the heat generated may be absorbed by surrounding masonry or carried up the flue. Large passageways such as fireplace smoke chambers and flues place the burning surfaces further from each other, so they contribute less heat to support each others' rapid combustion.

The attention of laboratory researchers has been focused primarily on large severe free-burning fires. In almost all published tests, the fire was burned with the stove door or cleanout open or adjusted to provide optimum air flow. In only one test, by Stone, the fire was allowed to burn with the stove door closed, but the thermostatically controlled air inlet was open for most of the test. This fire was also conducted in an insulated factory-built chimney, so no information was developed on the heat loss characteristics of masonry chimneys. In other words, there are unquestionably slower fires than those usually studied, but data on them is nonexistent.

However, Stone's test can serve to highlight at least one of the trends which are probably characteristic of slow chimney fires. In his test of a fast free-burning fire, Stone observed the flame front traveling at a rate of 26.7 inches per minute, taking only seven and a half minutes to traverse the 200-inch height of the chimney. In his relatively slow and more air-limited fire, the rate was only 13 inches per minute and lasted a total of 15 minutes. The maximum flue gas temperatures at each measuring point were only marginally higher in the fast test than the slow test. This

would seem to indicate that, although the fast test moved faster and pyrolyzed the creosote at a faster rate, it was not able to actually burn the evolved gases any more intensely than the slower fire. In other words, moderately slow chimney fires can produce a similar fire intensity but for a longer period of time.

Both tests involved flaming creosote, so we cannot directly conclude anything about very slow-smoldering non-flaming fires. It is undoubtedly true that non-flaming fires do not produce a flue gas temperature equivalent to that of a free-burning fire. However, the flue gas temperature is not the only factor, and to some extent it may be of only secondary importance. From the standpoint of chimney damage and the rate of heat propagation through the chimney wall, the behavior of the fire on the *surface* of the flue may be more critical. Smoldering creosote adhered to the flue wall may create surface temperatures comparable to those created by flaming combustion. Whatever the temperature, the longer duration of the presence of combustion on the flue wall will lead to more heat transfer into the chimney and more conduction of heat to the outside surface of the chimney.

Stone does not report the temperatures of the flue wall during his fires, but the relationship between the duration of the fire and heating of the chimney can be discerned in two tests conducted by Peacock for the National Bureau of Standards.^{11, 15}

One test involved an indoor masonry chimney coated with one-fourth to one-half inch of creosote. The other involved a similar chimney constructed outdoors and coated with roughly twice as much creosote. The chimney fire in the indoor chimney lasted about 30 minutes. The outdoor chimney fire lasted a little more than an hour. Both fires were free-burning, so the longer duration was primarily a function of the amount of fuel rather than any attempt to limit or slow fire progress. In the second fire, even though the maximum *flue gas* temperature recorded was less than the indoor fire, the maximum temperatures recorded for the flue liner and inside masonry surface were significantly greater.

Again, these results do not show directly the effects of slow-burning long-lasting chimney fires. They do, however, show that fires of longer duration have the capacity for greater heating of the chimney structure than fires which burn

intensely but last only a short time, and it is likely that the principle also applies to fires which only smolder on the surface for a long time. This effect is particularly important for masonry chimneys since their primary mode of protection is their mass and thermal inertia. A short intense fire will result in relatively little heat transfer through the chimney wall. A longer less intense fire will provide the time necessary to overcome thermal inertia and result in greater heating of the chimney.

The importance of slow chimney fires in the real world is demonstrated by the fact that their occurrence is often first detected during the investigation of a chimney-related structure fire. Unless the chimney has a fundamental structural problem such as a crack or other direct opening, free-burning chimney fires are usually contained to the chimney and do not cause sufficient conductive heat transfer to ignite adjacent combustibles. There is substantial anecdotal evidence that this is less true for slow chimney fires. It is not uncommon for fire investigators to find unmistakable evidence of a chimney fire even though the homeowner claims no knowledge of such an event. When pressed, the homeowner can often recall minor sounds or changes in appliance operation some time prior to detection of the structure fire. The time delay involved, plus the available physical evidence, seems to indicate that a slow undetected chimney fire was a major factor in ignition of the house fire.

2.3.4 DURATION AND EXTINGUISHMENT

Fixing the time when a chimney fire is “over” may be as difficult as knowing when it has begun. It may be best to think of the duration of chimney fires in terms of phases – a flame phase, and an after-flame or glowing phase. For free-burning fires, the flaming stage ends when the generation of gases by the burning creosote, supply of air, or retention of heat is no longer sufficient to support flaming combustion. It is likely to be followed by a period when the remaining solid residue burns with little or no flame as a glowing mass similar to wood charcoal. Slow chimney fires may never enter a flaming phase.

To the extent that the chimney fire progresses as an organized flame front, the after-flame phase will follow the flame up the chimney. When the flaming is finally exhausted at the top of the chimney, the entire flue may be covered with

patches of glowing creosote. Glowing may continue for an indeterminate length of time while the solid fuel is consumed and the chimney slowly cools.

The duration of the flaming phase is generally reported to vary from only three or four minutes to perhaps 20 to 30 minutes. However, in both the field and the laboratory, continued flaming combustion has been observed for up to an hour. The supply of fuel is a major factor in the duration of the fire, but some flaming fires may be partially self-limiting. For instance, if creosote expands and restricts or partially blocks the flue, the supply of air to the fire may be reduced such that flaming continues but fire progression is slowed. One example of this effect occurring in the laboratory was cited in section 2.3.1 in a test by Peacock.¹¹

Actions taken by the appliance operator to extinguish the fire may abort the flaming phase. As noted in section 2.3.3, the standard action to take is to close any obvious point of air entry into the system. This action is usually successful in limiting flaming but not in extinguishing the fire entirely. The fire cannot be considered to be truly “out” but could be termed a “controlled” chimney fire unless it flares to life when the stove door or cleanout is opened. If the homeowner has also called the fire department, the fire may be shortly extinguished. If the homeowner fails to call the fire department, the fire may smolder for a significant time, increasing the danger of ignition of the house structure.

Both because the duration of flaming of even an uncontrolled fire is relatively short and because homeowners often do take action to control the fire, many chimney fires are in the after-flame stage by the time the fire department arrives. The actions taken by fire departments to fully control and ultimately extinguish the fire vary significantly and are often used in combination. The most common techniques include – use of chemical extinguishing agents of various types with various methods of delivery; carefully controlled use of water; and removal or partial removal of burning residues. Further discussion of active extinguishment methods is beyond the scope of this report.

In summary, chimney fires are capable of burning for a significant period even in the flaming phase unless there is some intervention. Both slow chimney fires and the after-flame phase of free-

burning fires can last for a substantial period while still releasing significant heat. The detection and prompt extinguishment of chimney fires can have a bearing on the degree of damage and on the likelihood of extension to the house structure.

The standard advice given to homeowners to limit the entry of air is a sound first step in extinguishing a fire because this action will usually cut short the flaming phase. However, it may prolong the period of glowing fire and therefore should be followed by explicit efforts to actually extinguish the fire, preferably by the fire department. Extinguishment efforts can include the use of chemical agents or cooling water or both. Extinguishment should be followed by the monitoring of chimney and adjacent wall temperatures and by efforts to cool the chimney through its interior.

2.4 THERMAL CHARACTERISTICS OF CHIMNEY FIRES

Since chimney fires involve the rapid combustion of a fairly high-energy fuel in an enclosed area, they create “very hot” conditions inside the flue. It is often pointed out that chimney fires can result in a flue gas temperature of around 2000°F, and this is a fairly accurate and useful benchmark for remembering the power of a fire, but the thermal dynamics of chimney fires are much more complex and interesting than this single figure. Both the development of flue temperatures as a function of time and the thermal performance of the chimney structure under such exposure have as much to do with the safety consequences and potential for damage as does the absolute temperature achieved.

Most laboratory chimney fires have had as one of their primary purposes the study of the thermal effects of the fire. Research chimneys have been well instrumented with thermocouples, and voluminous data have been recorded and reported. Therefore, a good understanding of the thermal performance of chimney fires is available and is summarized in this section.

2.4.1 NORMAL OPERATION

A clearer understanding of the conditions created by chimney fires can be gained by comparing the conditions typical of normal operation. In order to set up their chimney fire burnout tests, all researchers have needed to build up creosote in their test chimneys. During these extended

periods of more or less normal operation, temperatures at various points in the chimney were recorded. This information is particularly valuable because it allows direct comparison of the performance of the same chimney during both normal and abnormal operation. Because the most complete data for both modes has been reported by Peacock,^{11, 15, 20} his results will be the primary references.

The chimneys used by Peacock were a total of 12 feet high with a nominal 12 by 12 clay flue liner. The chimney wall was a single wythe of solid brick four inches (nominal) in thickness. The flue liner was separated from the chimney wall by a one-inch clearance from the chimney wall consistent with the minimum allowed by most building codes. One of the chimneys was constructed outdoors and exposed to winter weather. Although most real-world chimneys are taller than 12 feet and many do not have the code-specified air spaces, the test chimneys were in most respects representative of properly constructed chimneys found in the field.

The chimney and surrounding enclosure were instrumented with thermocouples at a number of levels above the chimney inlet. Each level included an array of thermocouples that measured the flue gas temperature at the center of the flue, the outer surface of the clay flue lining, the inner and outer surfaces of the chimney wall, and the inner surface of the combustible enclosure. It is therefore possible to draw conclusions about the thermal conditions within the chimney and through its cross-section at various levels.

Smokey flue gases and, ultimately, creosote were supplied to the chimney by an airtight wood burning stove representative of many in use and connected to the chimney by a three-foot long single wall stovepipe. During the creosote accumulation phase, the stove was operated continuously 24 hours a day for several weeks in order to produce a significant buildup. The stove was loaded with full loads of wood and automatically controlled to maintain a steady low fire. Peacock reports that the average wood consumption rate was between two and three pounds per hour. This loading technique and consumption rate would be typical of that used by many homeowners during extended operation of the stove (for instance, overnight burns). In other words, the operating characteristics produced would be representative of the low end of the real-

world operating spectrum.

During this phase of testing, the flue gas temperature at the chimney base typically varied from 190 to 220°F. The outer surface of the clay flue liner was maintained fairly steadily at approximately 140°F while the inner surface of the chimney wall stayed near 115°F. The outer wall temperature was typically 100°F, and the plywood enclosure spaced an inch away rose to around 80°F. The temperatures of the flue gas and all surfaces at higher levels of the flue decreased steadily and tended to be closer together. Both the highest temperatures and the greatest difference in temperatures through the chimney cross-section were observed just above the stovepipe inlet.

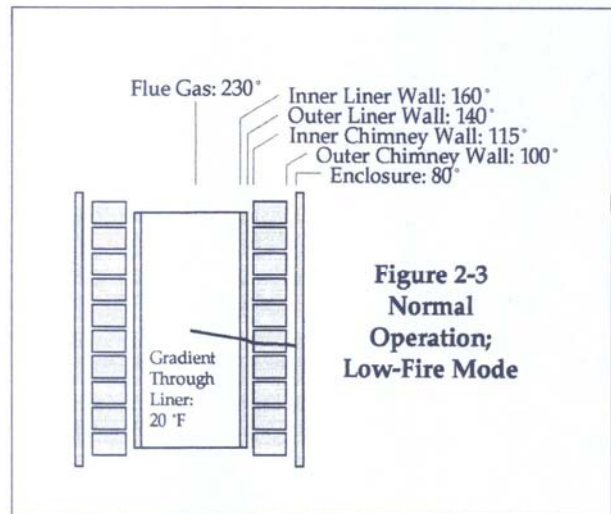

While the flue gas temperature rose and fell with changes in the fire intensity, the temperature of the liner and the rest of the chimney did not respond quickly to changes in the gas temperature. In fact, in many cases the flue gas had reached a peak and started to decline again before the liner had begun to rise in temperature. This illustrates the effect of thermal inertia – the ability of the massive chimney to absorb a large amount of heat while showing only a minor temperature rise. Because of the delay of masonry materials in responding to a change in flue gas conditions, a substantial difference in temperature can develop between the flue gas and the chimney materials. For this example of low fire operations, the variation in flue gas temperature was relatively minor, as it would be in a real chimney during normal operation. The greatest temperature differential between the flue gas and outer liner wall reported

by Peacock was only about 100°F and was even less through most of the test.

The inside of the liner, being exposed directly to the hot flue gases, responds more quickly than the exterior surface of the liner. A significant portion of the temperature drop from the flue gas to the outer liner surface will occur between the inner and outer liner surfaces. In other words, because the inner surface more closely follows the flue gas temperature, there will always be a temperature gradient through the liner wall.

Peacock did not record the temperature of the inner liner surface during these tests, but a reasonably accurate estimate can be derived by interpolating between the flue gas and outer liner temperatures. In general, the inner surface would have varied between about 150°F and 170°F during this steady low temperature operation. The temperature gradient through the liner wall was no more than 10 to 30 degrees. Figure 2-3 summarizes the typical temperature profile of the chimney during this type of normal operation.

In another series of tests²¹ with a different but similar chimney, Peacock produced fires more typical of the high end of the normal operating range. The chimney was of the same size and materials and was instrumented as described above. A wood-burning stove was also connected to the chimney. In this series, however, accumulating creosote was not the goal. Instead, the log fires were burned to approximate the high fire and overfire conditions that might occur in actual consumer use.

During the “normal” log fire test (which was actually significantly hotter than routine consumer operation), the highest temperatures were measured near the bottom of the chimney. In this case, however, the flue gases were mostly in the range of 570 to 750°F with one abrupt excursion to 966°F. During most of the test, the outer surface of the flue liner measured from 450 to 560°F – generally about 120 to 190 degrees less than the flue gas temperature. In the same period, the inner chimney wall rose from 185 to 320°F and the outer wall surface from about 110 to 230°F. This test with hotter flue gas resulted in a much wider difference among temperatures through the chimney cross-section.

The widest temperature differential occurred during a rapid rise in flue gas temperature from

about 650°F to 966°F. The temperature raised so suddenly that by the time the flue gas had peaked at 966°F the outer surface of the liner had just begun to respond and was still at about 610°F – a 356 degree differential. Again, the temperature of the inner surface of the liner was not measured but can be estimated to have been around 750 to 800°F at the time of maximum differential. The temperature gradient through the liner wall was approximately 140 to 190 degrees. Figure 2-4 shows the temperatures for all surfaces through the chimney cross-section during this peak temperature rise.

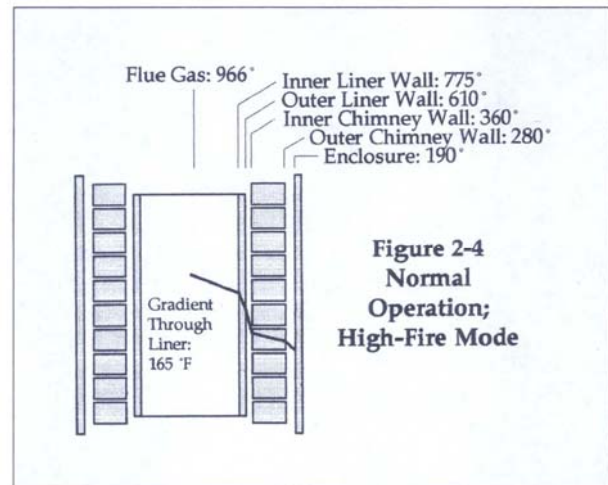

To summarize some of the effects of normal appliance operation on a masonry chimney: Flue gas temperatures will generally be in the range of 200°F to 600°F although excursions approaching 1000°F are possible. While flue gas temperatures can be expected to rise and fall periodically, they will generally do so within the range of a few hundred degrees. The masonry surfaces will not change in temperature as quickly or to such a great extent, and materials toward the outside of the chimney will respond most slowly. As a result, temperature differentials will develop between the flue gases and the masonry and through the walls of masonry materials. For most normal operating conditions, a differential between the flue gas and outer liner wall ranging from 200 to 400 degrees is possible. Between the inner and outer walls of the liner, a differential of 100 to 200 degrees is typical.

2.4.2 OVERFIRE OPERATION

In addition to the range of temperatures represented by low fire and high fire modes of normal operation, it is possible that an appliance

might be operated in a way that would expose a chimney to excessive, abnormal temperatures. These are overfire conditions where flue gas temperatures exceed 1000°F and may rise and fall with more abruptness over a wider range than is likely during typical consumer operation. Although flue gas temperatures can be quite high, overfiring is distinct from chimney fire conditions in that the flue contains hot flue gases rather than actual combustion.

Peacock has conducted two sets of overfire tests on tile that was later used for a chimney fire test¹¹ and one for comparison with the high fire normal operation tests cited above.²⁰ In both tests, similar peak flue gas temperatures were achieved, but in the pre-chimney fire test the rate of temperature rise was substantially steeper, and thus the temperature gradients developed through the chimney were more severe. The data for this test will be presented because it probably represents the most extreme overfire conditions likely to occur.

Overfire testing was conducted using a standard procedure developed by Underwriters Laboratories for testing solid fuels burning appliances. Specially constructed “brands” – oven-dry strips of Douglas fir lumber arranged in a lattice pattern – are added periodically to the stove. This creates an extremely hot fire with dramatic peaks and valleys of flue gas temperature in the chimney. A number of such flue gas excursions were created during Peacock’s test, generally involving a 600 to 700 degree rise over a period of 10 to 20 minutes.

The most dramatic such spike involved a flue gas temperature rise from about 530°F to 1421°F – an increase of 891 degrees over an approximately 30 minutes period. This spike also resulted in the greatest observed difference between the flue gas and chimney materials temperatures. At the time of the highest flue gas temperature, the outer surface of the flue liner was at about 570° - a differential of about 850 degrees. The inner surface of the chimney wall was about 200°F and the outer surface only at about 125°F.

Temperatures on the inner liner surface are not available, but careful interpolation between the flue gas and outer liner temperatures gives an estimate of between 1025 and 1175°F for the inner surface. The temperature gradient through the liner wall ranged from 500 to 600 degrees. Based

on the information from this most severe overfire test, a profile of the maximum temperature gradients likely to occur during periods of abnormal operation can be developed, as presented in Figure 2-5.

2.4.3 CHIMNEY FIRE CONDITIONS

The conditions created by a chimney fire differ both quantitatively and qualitatively from those of normal or even overfire operation. While both low- and high-fire normal operation includes variations in flue gas temperature, and overfire operation can result in more sudden and extensive temperature rise, neither compares to the rate and magnitude of temperature change during a chimney fire. Temperature gradients through the chimney structure are inevitable in any operating mode, but even the most abusive modes of stove operation are unlikely to duplicate the differentials that are typical of chimney fires.

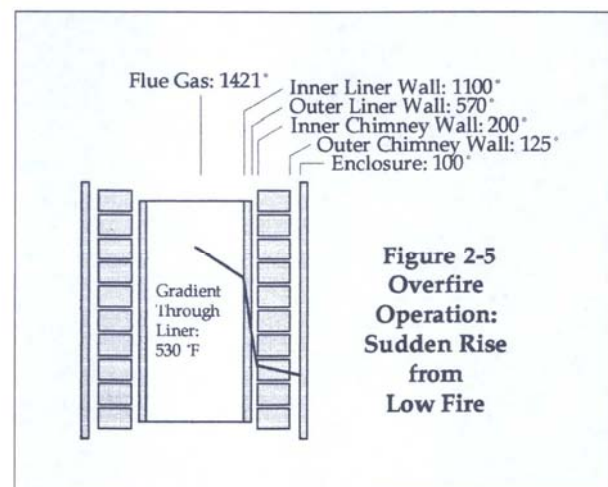

Peacock has published the results of two chimney fires conducted in masonry chimneys involving the interior and exterior chimneys described above. These results are supplemented by unpublished research by Shelton¹⁶ involving fires in five chimneys with different construction characteristics. With these resources, it is possible to draw a clear picture of the thermal performance of chimney fires and their effects on the chimney. Peacock had accumulated creosote in the chimneys naturally by burning a connected stove in a low fire mode over a period of several weeks. The amount of creosote collected during this period was significant. For the indoor chimney in which the buildup phase lasted a total of 823 hours, the thickness of the deposit was about one-fourth to one-half inch throughout the flue. For

the exterior chimney which was exposed to cooler temperatures and had an accumulation phase of 1368 hours, the deposit was from one-half to two inches thick. From Peacock's published descriptions and discussions with him, it appears that these thicknesses were composed of a combination of tar glaze creosote covered by a thicker layer of a partially expanded semi-pyrolized crusty form of creosote. Both the mixture of types and the thicknesses are representative of the deposits that are often found in consumer chimneys before a chimney fire.

Peacock ignited the chimney creosote by simply burning a very hot fire in the stove representing how most chimney fires begin. After it was clear that the creosote was ignited, the fuel was removed from the stove so that the effects of the chimney fire itself could be observed. Peacock reports that temperatures ranging from 1100 and 1300°F were obtained in the stovepipe before the fire was clearly ignited. As discussed in the section on creosote ignition, it is possible that the creosote had begun burning earlier or at lower temperatures but this was not evident because of the large fire in the stove.

At any rate, when the chimney fires got going, they were obvious. For the indoor chimney, the flue gas temperature at the base of the chimney rose from about 360°F to 2003°F, a change of about 1640 degrees in about five minutes. This peak was maintained only for a few minutes after which the flue gas temperature gradually declined to its original level over a period of 10 to 15 minutes. The flue gas temperature was over 1000°F for about eight and a half minutes. The fire in the outdoor chimney took longer to ignite. After about 30 minutes of gradually increasing gas temperatures up to about 600°F (in the chimney, not the stovepipe), the fire suddenly ignited and rose from about 640°F to a peak of 1677°F, a change of about 1037 degrees over a 15-minute period. However, this fire lasted longer than the other, probably owing to the presence of more creosote fuel. Temperatures above 1000°F lasted about 20 minutes and above 400°F for about 30 minutes.

Peak temperatures higher in the flue were less dramatic, as would be expected based on the theory of fire progression suggested by Stone.¹⁰ Since the creosote fuel toward the top was well-pyrolized by the heat from the fire below, it burned less intensely when the fire finally reached

it. For the indoor chimney, the peak flue gas temperature at the highest measuring point was about 1130 °F and for the outdoor chimney 1164°F. The record of flue gas temperatures also bears out Stone's prediction that the fire tends to travel progressively up the chimney. Data for the outdoor chimney, for which complete figures are available, indicate that each measurement level reached its peak temperature successively over a period of about eight minutes from exposure, both in maximum temperature rise and in the rate of rise, occurs toward the bottom and is progressively less further up the chimney.

Because of thermal inertia, the temperature performance of the chimney materials was similar to that discussed above for normal and overfire operation. Even while the flue gas temperature was rising sharply, the masonry materials lagged far behind. While the flue gas in the indoor chimney was peaking at 2003°F, the outer surface of the flue liner was still at about 220°F, a differential of 1780 degrees. The inner and outer surfaces of the chimney wall and of the plywood enclosure had not begun to respond noticeably to the fire at all and were still near their basal level near room temperature. The delay in temperature rise on the masonry materials was so significant that the outer liner surface did not reach its peak of 509°F until the flue gas temperature had actually declined to the same temperature, and the liner remained hotter than the flue gas for an extended period afterward.

As for the tests involving normal and overfire conditions, the temperature of the inner surface of the clay flue liner was not recorded but can be estimated by interpolation. However, because of the difference in heat transfer characteristics, the estimate cannot be made with the same assumptions. During normal and overfire operation, the flue liner is heated by hot gases flowing past its surface. The temperature of the gases is measured at the center of the flue where the gases are the hottest. The temperature of the gas stream declines further out from the center, so the actual gas temperature at the liner surface is significantly less than the temperatures cited in the reports. However, as Peacock point out, "during a creosote burnout, combustion takes place on or near the chimney walls. Thus, the measurement of the flue gas at the midpoint of the chimney may not indicate maximum temperatures in the chimney. Temperatures are likely to be considerably higher nearer the walls of the

chimney.”¹¹

Consequently, the temperature to which the liner surface is exposed will be closer to the measured flue gas temperature than it would be during overfire operation with a comparable temperature. A conservative estimate of the peak inner liner surface temperature during the indoor chimney fire test would place it somewhere between 1450 and 1750°F, and it may have been higher at specific locations where combustion near the surface was more intense. At the same time, the outer liner surface temperature is estimated to have risen only to about 450°F. Therefore, the temperature gradient through the liner wall was likely to have been between 1000 and 1300 degrees at the time of maximum differential.

The less severe and longer lasting fire in the outside masonry chimney probably resulted in a less dramatic temperature differential. At the time of maximum flue gas temperature, the outer liner surface was at approximately 400°F, a difference of about 1277 degrees. It is estimated that the inner liner surface reached a maximum temperature differential between the inner and outer liner surfaces was between 700 and 850°F. Even in the most severe overfire episode observed by Peacock, the estimated liner wall temperature differential was about 500 to 600 degrees. Even the more moderate chimney fire is likely to have produced a gradient significantly greater than found under overfire conditions.

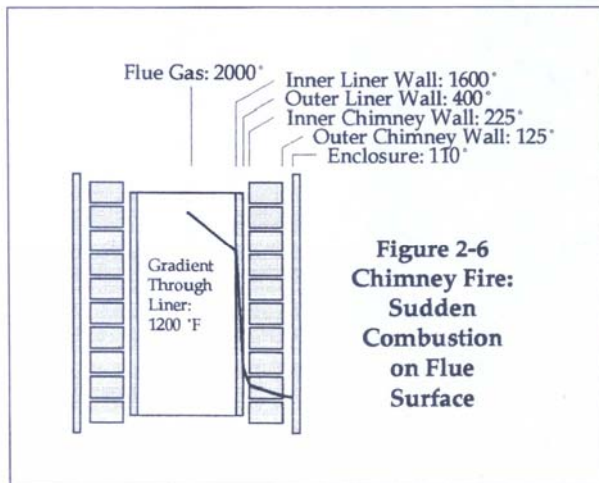

Figure 2-6 shows a characterization of the temperature profile through a chimney wall early in a chimney fire. Note that by far the most extreme temperature drop occurs through the wall of the chimney liner. The average temperature

differential presented here is about 1200°F. There are undoubtedly chimney fires that produce a more severe differential and probably some that are less severe. Because the distinguishing characteristic of a chimney fire is that combustion takes place at or near the inner liner surface, however, it is likely that the majority of fires are represented by a differential of the magnitude shown. Such a sudden and extreme temperature gradient through the liner wall often results in thermal shock fracture as we shall see.

Another difference between chimney fire conditions and normal or overfire conditions occurs in the opposite direction. While the temperatures of the chimney structure, particularly the outer portions, are slow to respond, they will tend to become *higher* during sustained overfiring and even normal operation than during a typically brief chimney fire. For both the interior and exterior masonry chimneys, the maximum temperatures on the outer brick surface and plywood enclosure were 114°F and 103°F respectively. By comparison, even the low fire creosote buildup phase of operation produced similar exterior wall temperatures of between 100 and 110°F and enclosure temperatures as high as 98°F. The high fire “normal” test resulted in a maximum exterior temperature of 277 degrees and an enclosure temperature of about 200 degrees. After a lengthy period of repeated overfiring episodes, the chimney wall temperature had risen to 593°F and the enclosure to 377°F.

The reason for this reversal is because, while chimney fires are very hot, they do not generally last very long. The masonry is able to absorb the large but brief burst of heat without developing high temperatures through the cross-section. In contrast, sustained operation, even with relatively low temperature, provides an opportunity for the heat to conduct through the chimney wall and cause surface temperatures to rise significantly. *Where the flue gas temperature is high and long-lasting (as in repeated overfiring), dangerous temperatures can be developed on exterior surfaces.*

One should not conclude, however, that chimney fires do not carry the risk of high exterior temperatures. The fire record testifies to the fact that some chimney fires are both hot enough and of long enough duration to expose nearby combustibles to potential ignition temperatures.

Shelton has also conducted a series of chimney fires in five chimneys. His results tend to confirm the observations and conclusions derived from Peacock's tests. Shelton accumulated creosote in the chimneys in a manner similar to Peacock, with sustained low fire operation of wood stoves. However, all of his chimneys were located outdoors, so the rate of accumulation may have been higher. The overall thickness of the deposits was not reported, but the total *weight* of the creosote in the 16 foot high chimneys was reported as between 5.5 and 8.9 lbs. The amount of creosote present was therefore somewhat less than is often found in field chimneys and probably less than produced by Peacock.

Maximum flue gas temperatures for each of the five fires varied from 1508 to 2066°F with all but the lowest above 1740°F. In all cases, once ignition was established, the flue gas temperature at the bottom of the chimney rose from less than 500 degrees to at least 1500 degrees in a period of no more than two to three minutes. As in Peacock's tests, the maximum temperature recorded at the chimney top was lower by 300 to 700 degrees than at the bottom and was attained several minutes later. Because the amount of fuel was less than in Peacock's tests, the duration of the fires was generally shorter. The peak flaming

stage of the fire appears to have been from as short as three minutes to as long as about 15 minutes.

The behavior of the chimney materials was similar to that observed by Peacock. While the fire intensity was at its peak, the chimney components were only beginning to respond to the rise in temperature. A typically steep temperature gradient was set up through the chimney cross-section, and by the time the outer materials reached their peak temperature the flue gas temperature had fallen back to normal levels. Shelton did not directly measure the temperature of the flue liner, so an estimate of the temperature gradient cannot be made. However, the temperature performance of the gap between the liner and chimney wall, which was measured, closely parallels the time/temperature curve for the inner chimney wall shown by Peacock. It is likely that the flue liner was subject to a similar gradient as was derived from Peacock's data.

Shelton's results permit several additional observations. Even though the amount of fuel was less, flue gas temperatures were comparable to Peacock's results with more creosote. In other words, *the amount of fuel present may not have a large effect on the intensity of the fire as*

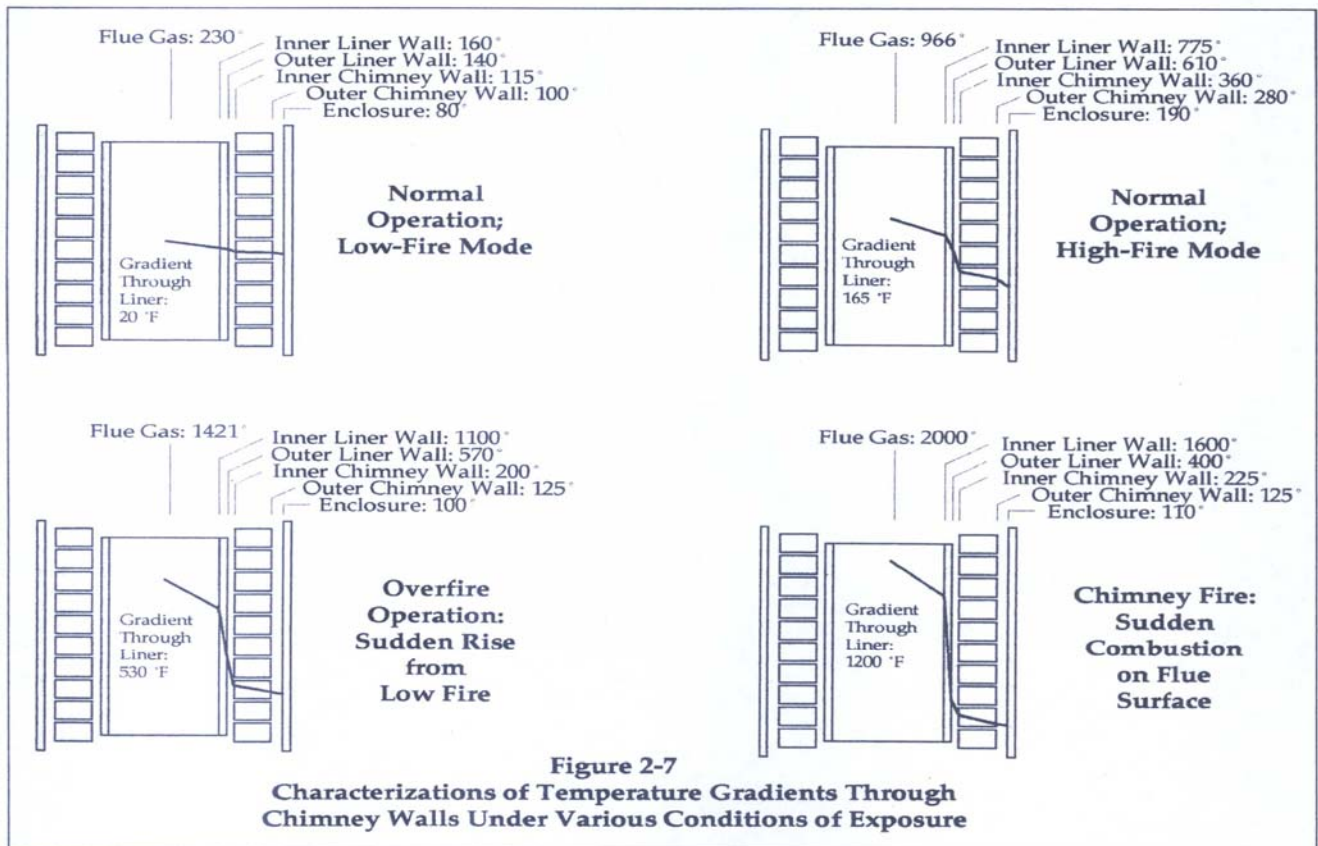

represented by flue gas temperatures. Instead, the amount of fuel may more directly influence the duration of the fire and the amount of time that elevated temperatures are maintained. The duration of the fire has a significant effect on temperatures developed on the exterior of the chimney and therefore on the risk of ignition of the adjacent structure.

The rate of flue gas temperature rise also does not appear to be dependent on the amount of fuel. Once ignition was accomplished, the fire at the chimney base grew quickly in intensity so that it was producing “chimney fire temperatures” (above 1500°F) almost immediately. The fire does not spread immediately up the chimney, however. Peak temperatures toward the top will be lower and slower-developing than those at the bottom regardless of the amount of fuel present. In short, *most chimney fires with both large and small amounts of creosote will tend to develop a very rapid rise in temperature at the bottom while conditions further up the flue will tend to be progressively less severe.*

Based on the data produced by Peacock and Shelton, it is possible to produce a general characterization of the profile of temperatures through a masonry chimney cross-section under various modes of operation. The temperature profiles illustrated separately in Figures 2-3 through 2-6 are gathered together for comparison in Figure 2-7. No single diagram or set of diagrams can fully represent the many possible variations in chimney construction and mode of operation that occur in real world situations. Because these characterizations are based on data from the same or similar chimneys, however, they may be useful for comparing the general conditions that are characteristic of each mode.

2.5 SIGNS AND EFFECTS OF CHIMNEY FIRE OCCURRENCE

Regardless of the type of chimney fire and how or when it was extinguished, it can be expected that evidence of its occurrence will be left behind. Not every chimney fire will leave the same set of signs and effects, but because a fire creates conditions so dramatically different from those of a normal heating operation it is likely that every fire will cause changes in the physical state of both the creosote deposits and the chimney itself. Some of the more common and recognizable characteristics of post-fire conditions are summarized below.

2.5.1 CREOSOTE CONDITION

Just as charred wood is an unmistakable sign of a structure fire, so is the unique condition of the creosote fuel after a chimney fire. When heated, tar glaze creosote behaves as a viscous semi-liquid and when heated vigorously it pyrolyzes rapidly. The gaseous pyrolysis products bubble underneath the surface which is relatively strong and flexible. As the bubbles burst, combustible gases are released which fuel the flames of a free-burning fire.

During rapid pyrolysis, creosote will foam and expand markedly, as do many viscous fuels. As the pyrolysis products are driven off, a substantial amount of solid material which does not shrink back or decompose is left behind. Instead, it tends to “freeze” in place; retaining the outlines of the bubbles that were present at the instant that pyrolysis was complete. The details of this unique phenomenon have not been studied, but the effect has been observed in both the field and the laboratory. It is likely that the noncombustible components of creosote are evenly distributed throughout the fuel and are able to form a structural matrix capable of supporting its own weight around a bubble if the liquid is suddenly removed.

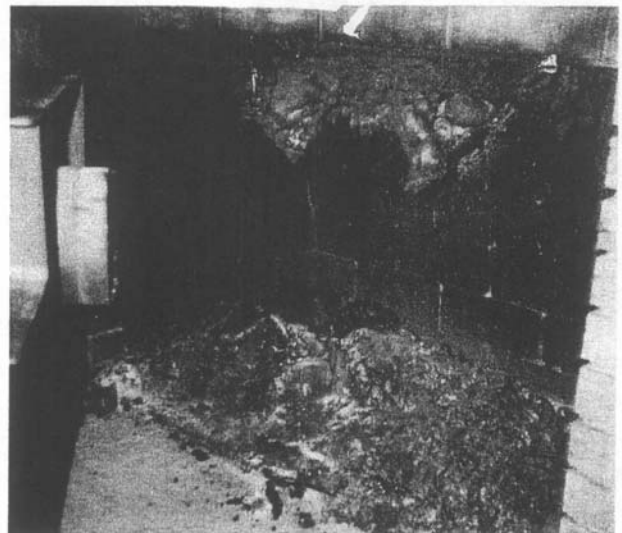

Figure 2-8. The aftermath of a chimney fire is marked by a large quantity of pyrolyzed creosote residue in highly expanded form. Ash is six or more inches deep on the firebox floor and a large mass is hanging from the fireplace damper area.

At any rate, as a chimney fire progresses it leaves behind a dry expanded deposit with a foamy or flaky consistency which can be compared to a dry lightweight sponge or a wasp’s nest. As often

happens, creosote may pyrolyze in uneven layers, so another common form is a series of tissue-thin leaves which have been likened to a French pastry. Although exposure to hot flue gases during normal operation also causes creosote to pyrolyze, the character of chimney fire residue is distinctive. Slowly pyrolyzed creosote will be much denser with fewer bubble outlines. When crushed, it will be distinctly granular.

In contrast, post-fire creosote residue is extremely lightweight and fragile. It will retain only a fraction of its original weight and will have expanded to many times its original volume. In many cases it has swelled to nearly block the flue, and this can be related to back-puffing or smoke spillage during the fire. The deposit is so fragile that it will often break apart from just a touch. When broken, it will tend to form thin flakes for leaves which are so light that even a slight breeze will blow them away. Photographs of typical post-fire creosote, cut open to show the foamy internal structure, are shown in Figure 2-9.

In an experiment conducted for this report, samples of actual tar glaze creosote were softened and removed from a chimney flue and formed into cubes of approximately one to two cubic centimeters (cc). The cubes were carefully weighed and measured and then fully pyrolyzed by burning them with a torch. The samples foamed, flamed, and solidified as they would during a chimney fire. The torch was applied until the sample was no longer able to support a flame, i.e., until all the gaseous pyrolysis products were driven off. After the torch was removed, the

samples stopped glowing almost immediately; suggesting that little if any combustible solid material remained. The remaining residue was then re-weighed and measured and the percentage change in volume was calculated. Photographs of the creosote samples before and after pyrolysis are shown in Figure 2-10, and the weight, volume, and density data for each sample are shown in Table 2-1.

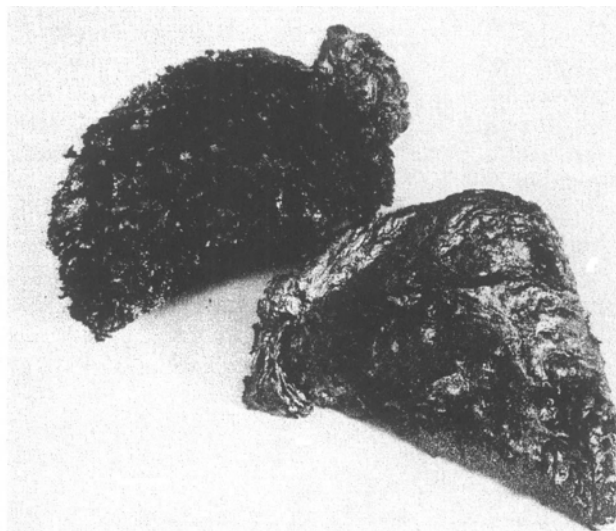

Figure 2-9

On average, the samples lost about 68 percent of their original weight, and the results were remarkably consistent for all samples. This suggests that, at least for the particular creosote found in this chimney, the non-combustible ash content is about 32 percent. Before being heated, the samples had an average density of about 1.02g/cc – just slightly more than the density of water. After full pyrolysis, however, the density

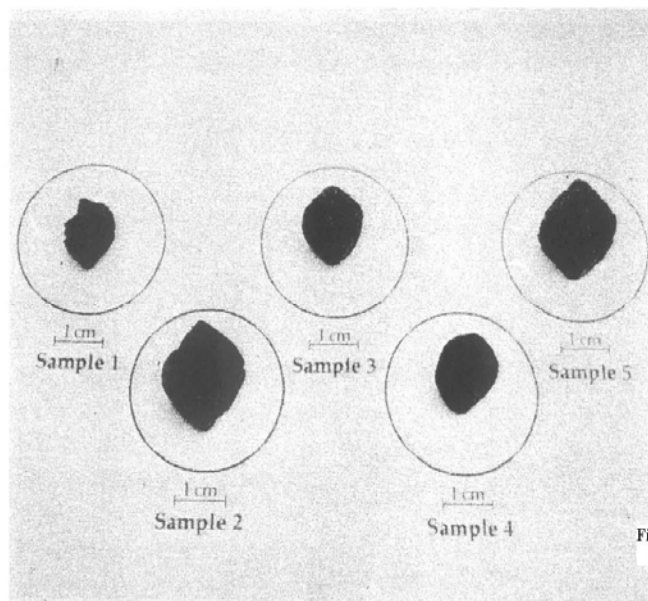
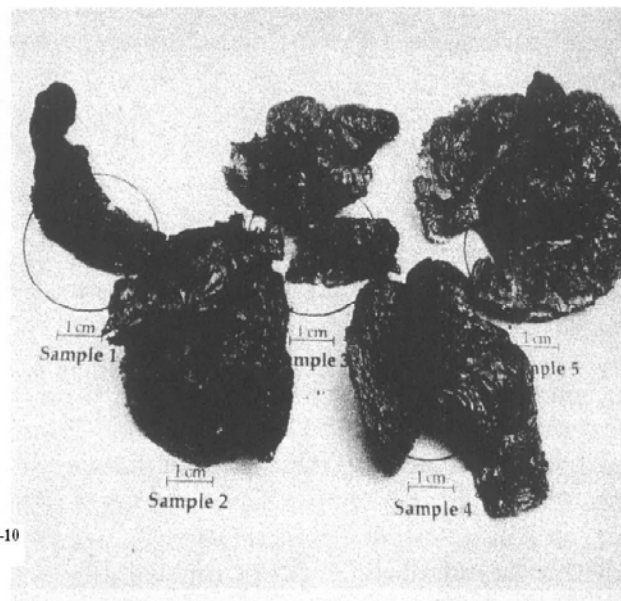

Figure 2-10



was only about 3 percent of the original. In contrast, partially pyrolyzed samples of creosote, taken from the same flue, had a density of about .45, or about 15 times the density of the fire-pyrolyzed material.

This dramatic decrease in density was due both to the loss of weight and to the increase in volume. With the exception of Sample 1, which may have contained less volatile material than the others, all of the samples grew from 10 to 27 times their original volume with an average expansion of nearly 1400 percent. In other words, if the original deposit were evenly spread on the surface of chimney flue to a thickness of one-fourth inch, and completely burned as in this test, the expanded creosote residue would end up about three and a half inches thick. For an 8 by 12 nominal modular flue liner, this would essentially block the flue.

These results were for a particular sample of creosote heated in a particular way. The quantitative results may or may not be the same in any specific chimney subjected to a chimney fire. Both lesser and greater changes in density and volume can probably be expected. However, the

creosote samples had the same characteristics as the material typically found after a fire, and they were created in much the same way. It is likely, therefore, that, qualitatively, creosote subjected to a chimney fire goes through changes similar to those recorded here and forms a distinctive residue that cannot be mistaken for normally-pyrolyzed creosote.

It is often, though not universally, true that post-fire creosote residue will not support further combustion attempts to ignite fully-pyrolyzed deposits with a flame will result in a glowing of the affected surface which will disappear when the flame is removed. Not all deposits become fully pyrolyzed, however. Early interruption of the fire may leave deposits, particularly in the upper portion of the chimney, pyrolyzed and expanded, but still capable of burning with flame. Particularly thick deposits will tend to form an overlying layer of well-pyrolyzed material which may insulate underlying deposits, preventing them from burning or fully pyrolyzing. In other words, non-combustibility of creosote residue is a good indication of a full-blown fire, but it is not a necessity. The presence of extremely light,

**Table 2-1
Changes in Creosote from Burning**

Sample Number	Weight of Sample (grams)			Density (g/cc)		Percent of Original Volume
	Before	After	Percent of Original	Before	After	
1	.709	.199	28.1	.9642	.1009	268
2	2.369	.871	36.7	1.0590	.0289	1347
3	1.160	.358	30.8	1.0316	.0292	1097
4	1.245	.398	31.9	1.0150	.0116	2785
5	1.994	.602	30.2	1.0185	.0209	1471
Average	1.495	.485	32.5	1.0176	.0383	1393

foamy, or flaky deposits is good evidence of a fire even if some residual fuel value remains.

Because typical creosote apparently contains a fairly large percentage of non-combustible ash, creosote is not generally “consumed” by a chimney fire even when it is burned to extinction. When the samples from the above experiment were again subjected to the very hot flame of a propane torch, they essentially refused to burn up. They did become incandescent when subjected to the flame, and it was possible to burn a small hole in the sample by holding the torch in one spot for several minutes, but the rest of the sample remained intact and held its foamy structure. It therefore seems likely that the assumption that a chimney fire will automatically “clean a chimney” is a myth.

Actually field experience confirms that a small minority of fires do remove most of the deposits, leaving a nearly clean flue. These fires appear to usually involve intense free-burning combustion with a relatively small amount of deposit and very high draft. The creosote is not actually consumed by the fire, but is torn off the walls and carried out the flue by the high draft or falls to the bottom of the flue. The expelled residue can be found all over the roof and yard unless it has been carried away by wind or rain.

Occasionally, a glaring bare spot will be seen in an otherwise creosote-laden flue. The area will often appear scoured clean down to the original tile color. Such an area denotes a zone of extremely intense combustion where even the soot stain has been burned off the flue. It is likely to be a location of spalling of the liner surface where the temperature gradient near the surface rose so quickly that hot expanding layers sheared from the adjacent cooler material. *Frequently, the reason for such intense combustion is an air leak through a nearby liner joint or crack.* Under the strong negative pressure inside the flue, a jet of flame can emanate from such an air source. The adjacent deposits can be “incinerated” by the intense combustion or blown off the wall by localized turbulence.

More commonly, however, the flue is far from clean after a chimney fire. *For a fire which burned until extinction, or became well-developed before extinguishment, well-pyrolized deposits are likely to be found throughout the chimney flue.* Many fires are limited before they involve the entire

chimney, however, and fully pyrolized deposits may be found mainly at the bottom. Deposits in the upper sections may be partially pyrolized by heat from the fire below but may hide underlying unaffected material. Overall, the flue will tend to have a distinctly disorderly look with areas of greatly expanded residue next to less affected deposits.

For slow chimney fires in particular, it is possible for the fire to have crawled up just one wall of the flue without igniting adjacent deposits. Although infrequent, such fires result in uneven and occasionally patchy areas of pyrolized creosote surrounded by more normal deposits. This appears to be most common in large fireplace smoke chambers where the greater distance between burning walls works against developing the temperatures necessary to fully involve the entire chamber.

The presence of non-uniformity in the flue is one of the more distinctive signs of a chimney fire. During normal operation creosote is deposited more or less uniformly. There may, of course, be differences in the amount or type between the upper and lower portions of the chimney, but the changes are usually gradual. Similarly during normal operation, creosote is pyrolized by hot flue gases which may affect different deposits to different degrees, but it is not usual to find abrupt discontinuity in the deposits unless they have been subjected to the disorderly phenomena of a chimney fire.

Although, typically, a large percentage of the creosote residue remains adhered to the flue wall, some of the material may be found expelled from the flue, and usually a significant pile of loose debris is found at the bottom of the chimney, in the smoke chamber, or the cleanout area. These are deposits which were broken off during the fire, and they will usually be fully-pyrolized and very lightweight pieces.

It is not unusual to find that a substantial amount of tar glaze creosote has melted away from the fire and has not been pyrolized at all. Frozen drips or large glacial masses of tar are sometimes found below the stovepipe inlet to the chimney or in isolated corners of the fireplace smoke chambers. Tar glaze can also melt and drip from chimney caps early in a fire and be found in a frozen pool on the top of the chimney.

By the same token, sometimes *burning* tar will drip or flow to lower parts of a chimney, carrying the fire to a location that it would not otherwise reach. *The presence of pyrolyzed creosote adhered to flue walls below the normal source of heat is a sure sign that a chimney fire has occurred.*

Because all chimney fires are different, not all of these signs will show up in all chimneys. No fire can take place without significantly altering the fuel, and chimney fires are no exception. If a fire has taken place, it is likely that the condition of the creosote will bear unmistakable witness to the event.

2.5.2 EFFECTS ON CHIMNEY AND OTHER OBJECTS

Although it cannot be said that *all* chimney fires cause damage, there is extensive evidence that they *can* and very often *do* result in damage to the chimney or adjacent objects. There are numerous examples of damage caused to actual consumer chimneys during accidental fires, but the patterns and extent of chimney fire damage observed in the field have also been replicated in the laboratory as a result of fires set for the purpose of study. Consequently, the types of damage typical of chimney fires are well documented as are some of the reasons and conditions necessary for damage.

Damage To Flue Lining

Since the flue liner is the part of the chimney most directly exposed to the fire, it is both logical and empirically true that it is most likely to suffer damage. The most common and predictable type of damage observed in the field is fracture of the clay flue lining. Typically a crack, or cracks, will extend in a generally longitudinal (lengthwise) direction through one or more sections of flue liner. In general, such damage is most likely to occur toward the bottom of the flue, but it is not at all uncommon for this pattern to extend through all or most of the flue from the top to bottom. Although rare, it is also possible for the circumstances of fire spread or intensity to have caused damage only toward the top or at some isolated location in the flue.

Longitudinal cracking is sometimes accompanied by more extensive damage, such as additional transverse or diagonal cracks or completely “blown out” pieces of flue liner. These appear to be related to particularly severe fires or to

locations of greater fire intensity within the flue.

Transverse cracking is rarely, if ever, found by itself. A longitudinal crack is always present in a liner section that has any other form of cracking. When longitudinal cracking is present throughout the chimney, the sections with additional cracks will tend to be concentrated toward the bottom, where most fires begin and are more intense. It therefore appears, based on field experience, that the primary mode of liner failure is longitudinal cracking. When conditions are severe enough, additional cracks secondary to the initial crack may also develop.

The predominant pattern of longitudinal cracking has been observed in all laboratory studies of chimney fires involving masonry chimney without exception. In both of the chimneys tested by Peacock, damage was observed, and, referring to the indoor chimney, he reports that “inspection of the masonry chimney after the creosote burnout test revealed cracks along the molding seams¹⁷ of the tile liners 6 to 12 mm (1/4 to 1/2 inch) in width along the entire length of the chimney. Numerous smaller cracks were evident throughout the liner sections upon subsequent disassembly of the chimney.”^{11, 18} Figure 2-11 shows a photograph of these cracks taken during disassembly.

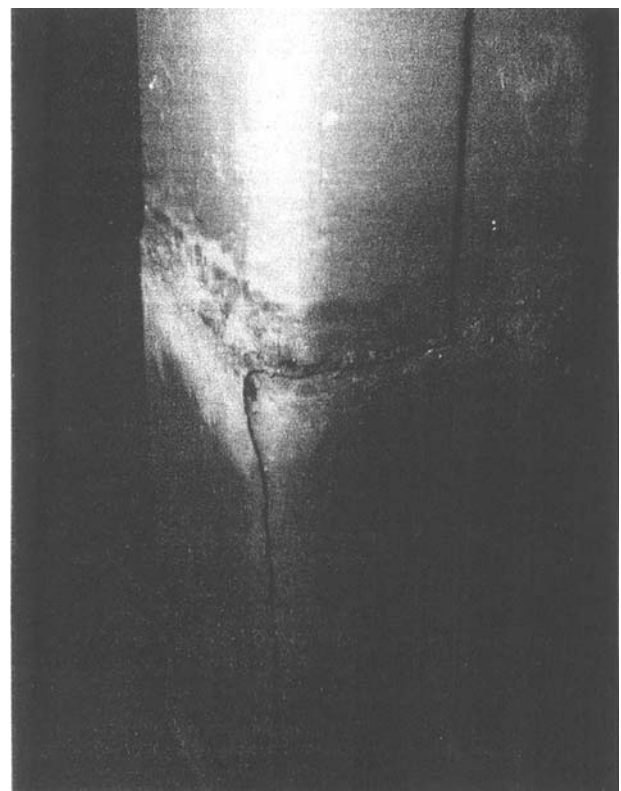

Figure 2-11

NIST Photo

The mechanism of liner fracture is thermal shock. As discussed in Chapter 1, clay flue lining has been around for at least 85 years and has evolved into a reliable product for containing the products of combustion. Clay lining is designed to withstand the temperatures and exposure conditions from normal operation of the appliance. As defined by codes and certain test standards, “normal” operation includes flue gas temperatures up to 1000°F and the presence of both corrosive and erosive products in the flue. Limited episodes of overfire operation, when flue gas temperatures rise above 1000°F for short periods of time, must also be anticipated.

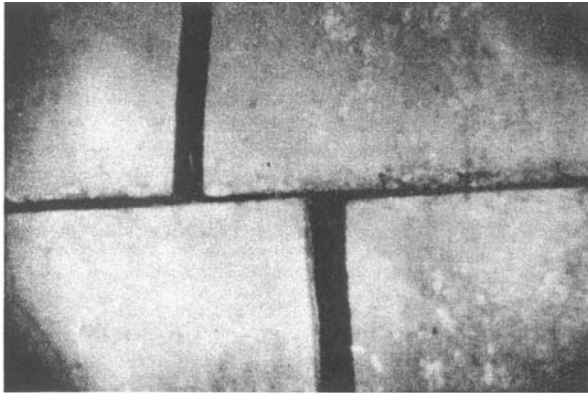

Figure 2-12. Video chimney scanner image reveals severe vertical (longitudinal) cracks in two clay chimney liner tiles following a chimney fire. The horizontal line is the joint between the two tiles.

Normal operation will inevitably involve temperature variations at different locations on the flue surface and changes in temperature over time. The key element of normal operation, however, is that such variations occur over a limited temperature range with a relatively slow change in temperature. There is thus an opportunity for heat to conduct through the wall of the flue lining, and the temperature difference between the inside and outside surfaces is limited. Clay flue lining is designed to withstand the moderate strains produced by these temperature differentials.

A chimney fire, however, involves the sudden presence of actual combustion in the flue. Both the amount of heat transferred to the liner and the rate of heat release are far higher than that produced by normal operation. Furthermore, combustion takes place in deposits on or near the surface of the lining, making heat transfer that much more sudden and direct. Flue gas temperatures of 2000°F and liner surface temperatures of 1500 - 1700°F have been recorded in laboratory tests. The key, however, is not the

absolute temperature produced, but the speed with which the temperature is applied.

The sudden exposure to high temperatures will set up a steep temperature gradient from the hot inside to the cooler outside of the liner wall. Clay flue lining expands when it is heated like nearly all materials. The hot interior of the flue will be expanding to a much greater degree than the cooler exterior. Clay flue lining, as a ceramic material, is quite brittle and will crack under the strains produced by such severe thermal shock. *For reasons related to the tubular geometry of the liner, the initial crack must almost invariably be longitudinal.* The effect is analogous to the rupture of a frozen water pipe. Pressure from inside will nearly always cause a longitudinal rift starting on the outside unless re-directed by a latent defect in the material. If the shock to the flue liner is severe enough, additional cracks running any direction may also develop.

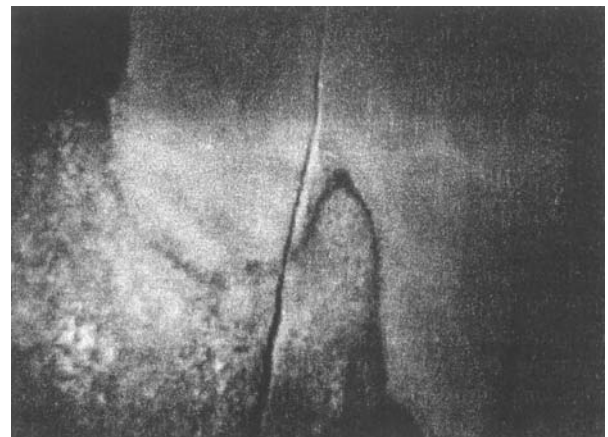

Figure 2-13. This image produced by a video chimney scanner shows a typical burn pattern in a chimney tile and a vertical crack in the tile – both are the result of a chimney fire.

It is worth noting that while all reported chimney fires in laboratory chimneys resulted in cracking of the flue lining, normal operation and even overfire testing of the same or similar chimneys did not result in damage to the flue lining. It would be incorrect to suggest that flue lining cannot be damaged by normal or overfire operation since both chimney construction and the severity of consumer operation are not necessarily the same as observed in published tests. It is almost certainly true, however, that the thermal shock conditions set up by chimney fires are more likely to result in the characteristic damage described above. Thermal shock will be more fully explored in Chapter 4.

Liner cracks may be found either wide open or closed down to a “hairline” width. Both forms were observed by Peacock. While the cracked liner is hot it will be expanded outward, causing a gap to develop between the edges of the crack. Upon cooling, the liner will attempt to contract back to its original dimensions, and the crack’s edges may fit back into their original position. However, pieces of broken liner, mortar, or other material may become lodged in the crack while it is open, preventing the full return of the edges. Latent stress in the liner body itself may also cause the edges to be displaced relative to each other in any direction. Thus, both closed hairline cracks and open or displaced cracks are characteristic of chimney fire damage.

If a chimney is inspected soon after a fire, before the appliance is put back in service, the exposed crack surfaces may have a “new” appearance. The exposed edges will be sharp, and the liner material inside the crack may be clean and free of creosote deposits, showing the original color of the liner. This is not always the case, however. Melted creosote can flow into the cracks during the fire and disguise their new appearance. If the chimney is used to carry smoke after the fire, it is likely that smoke stain or creosote buildup will have begun to cover any exposed surfaces.

In addition to cracking, the liner may suffer from another form of damage called “spalling.” This phenomenon, which is also caused by thermal shock, is a loss of material from the inner surface of the flue. Flat plates or leaves of material will have sloughed off in a localized area, leaving a gouged-out crater. Spalling occurs at locations of very intense and sudden temperature rise and results from the shear stress between the rapidly expanding surface layers and the cooler underlying material. *Spalling can usually be linked to the occurrence of a very severe free-burning fire, or to a flame jet resulting from an air leak into the flue, and is often found in conjunction with an unusually clean area of the flue.*

The joints between liners can also be damaged by a chimney fire. Standard Portland cement-based masonry mortar, which is often (though incorrectly) used to fill liner joints, suffers a dramatic loss in strength at temperatures above 1000°F, which is easily achievable during a chimney fire. The material may spall or crumble and fall out during a chimney fire or after

subsequent exposure to the elements. Sodium silicate-based cements may also soften under chimney fire temperatures although they are unlikely to literally run out of the joint.

Damage To Chimney Wall

The flue liner is the “first line of defense” of a masonry chimney against damage from abnormal operation, and it usually does its job well even though it may suffer damage in the process. In some fires, however, the severity of the fire or construction details may result in damage to the chimney wall itself. Although there are no detailed statistics on the relative incidence of liner damage versus chimney wall damage, it appears that fires which cause damage to the wall are a small subset of those which damage the liner.² In other words, a chimney fire is most likely to damage the flue, and some fires cause additional damage to the surrounding wall.

Although it is relatively rare, sometimes enough heat can penetrate to the chimney wall quickly enough to cause cracking of the exterior brick or block. Like clay flue lining, fired clay bricks are ceramic products and behave under thermal shock in similar ways. Concrete blocks are not ceramic *per se*, and their more porous structure may make them more shock resistant. Nevertheless, fires of sufficient intensity, and especially *duration*, have been known to crack both brick and block.

The circumstances necessary for chimney wall cracking suggest why it is substantially less common than flue liner damage. In order for thermal shock to occur, a temperature gradient must be set up through the chimney wall. Particularly when the weather is cold, the exterior temperature will be low and be inclined to stay low because of convective cooling. However, several studies have shown the substantial insulating value of clay flue lining combined with the code-specified annular air space.²⁰ Since it is the delay in heat conduction through the liner, substantial time will need to pass before the liner will begin to contribute a large amount of heat to the chimney wall. Studies by Peacock,^{11, 21} have illustrated the relatively slow rise in temperature of the chimney wall.

Obviously, the intensity of the chimney fire – the absolute temperature achieved within the flue – affects the amount of heat reaching the chimney wall. However, probably of more importance is the duration of the fire – the length of time during

which high temperatures may pass through the liner to the wall. If the fire is hot and long-lasting enough, a temperature gradient large enough to cause thermal shock fracture may be set up through the chimney wall. *The lack of the code-specified air space between the liner and chimney wall will increase the likelihood of both liner and chimney wall fracture.* In addition, unlined portions of the venting system, such as the walls of the fireplace smoke chambers directly exposed to a chimney fire, may also be particularly susceptible to thermal shock failure.

If thermal shock crack does develop in the chimney wall, it will most likely be primarily vertical and will tend to cut through masonry units rather than to follow mortar joints. However, because the interface between brick and mortar is a natural plane of weakness, the crack may follow some joints.

As noted in Section 2.3.2, axial expansion of the flue liner can be substantial, particularly during fires of longer duration. If the top of the chimney is firmly anchored to the top flue liner, the liner will be unable to “grow” out the top and may instead lift the top of the chimney. The result will be a fully broken bed joint encircling the chimney. Although this curious effect may be visible during the fire, it is common for the chimney to resume its original position after the liner cools and contracts. Obviously, the cracked joint will still be there, but it may be very difficult to detect unless debris has lodged in the crack and prevented the full return of the top.

Damage To Other Objects

Chimney fires are also likely to have an affect on other parts of the heating and venting system. Black stovepipe will show light gray oxidized patches which correspond to areas of intense combustion in the connector. Dampers and other metal parts of fireplaces can be warped by the fire. Fireplaces with formed metal smoke chambers can be warped to the extent that all sides bow inward. Objects at the top of the chimney can show varying degrees of exposure to high temperatures. Aluminum rain caps and antennas can be literally melted by a fire, and steel caps can be warped. Black painted or stainless steel caps will often show heat discoloration. The severity of damage is affected by the severity of the fire. A slow chimney fire, or one that was extinguished before flaming reached the top of the chimney, may

cause more subtle damage. It should not be assumed that because damage is not catastrophic, a chimney fire did not occur.

Damage To House

The potential carried by a chimney fire for damage to the house has been discussed. Blockage of the flue or backpuffing during a fire can cause substantial smoke to spill into the house. A relatively small percentage of chimney fires result in ignition of the house structure, either from the expulsion of brands onto a combustible roof or from the conduction of heat through the chimney wall to adjacent combustibles. The likelihood of ignition from conducted heat appears to be most influenced by the duration of the fire rather than its intensity. In addition, a small percentage of fires may result from the direct escape of hot gases or flames through the cracks in the chimney walls.

NOTES

1. See, for instance, *Final Report, Fiscal Year 1984 Metal Chimney Project*, US Consumer Product Safety Commission, 12/31/84.
2. *The Wood Heating Alliance's National Survey of Chimney Fires, Year 2 -1988/89*, Philip Shaenman & Charles Feldman, TriData Corporation, July 1989.
3. *Chimney Fire Experiments*, Jay W. Shelton, Shelton Energy Research, Santa Fe NM, 1981.
4. See, for instance, *An Investigation of Creosoting and Fireplace Inserts*, T. T. Maxwell, D. F. Dyer, G. Maples and T. Burch, Auburn University, NBS-GCR-365, December 1981.
5. This is a necessarily simplified treatment of wood combustion. There is extensive technical literature on wood pyrolysis and combustion, some of which is listed in the Bibliography of this report. Most of this discussion is adapted from books by Jay W. Shelton: *The Woodburners Encyclopedia* (1976); *Wood Heat Safety* (1979); and *Solid Fuels Encyclopedia* (1983).
6. “Combustion, Combustibility, and Heat Release of Forest Fuels,” Fred Shafizadeh, American Institute of Chemical Engineers Symposium Series No. 177, Vol. 74, 1978.
7. *Theories of the Combustion of Wood and Its Control*, F. L. Browne, Forest Products Laboratory, US Dept. of Agriculture, Madison, WI, 1963.
8. *Solid Fuels Encyclopedia*, Jay W. Shelton, Garden Way Publishing, 1983.
9. Although there is extensive literature on the subject of ignition of wood exposed to long-term heating, the best single

survey of the phenomenon is found in Part II *Performance of Type B Gas Vents for Gas-Fired Appliances*, Underwriters Laboratories Bulletin of Research No. 51, May 1959.

10. "Solving the Creosote Problem," Richard L. Stone, (Wallace Murray Corporation), *Fire Journal*, January, 1980.

11. *Intensity and Duration of Chimney Fires in Several Chimneys*, Richard D. Peacock, National Bureau of Standards, Center for Fire Research, NBSIR 83-2771, 1983.

12. This procedure and apparatus is, of course, only valid for combustible liquids. Even though tar glaze forms a viscous semi-liquid when heated, no claim is made that an actual flash point was determined. However, the test does help clarify the heating conditions necessary for the piloted ignition of one form of creosote.

13. Assuming a coefficient of thermal expansion for structural clay tile products of $3.3 \times 10^{-6} / F$, as suggested by *Technical Notes on Brick Construction*, No. 18: "Differential Movement," Brick Institute of America, Reston, VA, July, 1984.

14. "Factory-Built Chimneys," Carl R. Flink, Energy Testing Laboratory of Maine, *Proceedings, Wood Heating Seminar 4*, Wood Energy Institute, 1979.

15. "Wood Heating Safety Research: An Update," Richard D. Peacock, National Bureau of Standards Center for Fire Research, *Fire Technology*, National Fire Protection Assn., Vol. 23, No. 4, November, 1987.

Note: The test of the indoor masonry chimney is also described in Reference 11. Information on the outdoor chimney is included in this Reference, and supplemented by

details provided by Mr. Peacock.

16. Jay Shelton, Shelton Energy Research, Santa Fe, NM. Unpublished, proprietary research involving chimney fires in five masonry chimneys with different construction characteristics. Made available to this project by the client on a provisional basis, cannot be duplicated.

17. Because they are extruded as a continuous tube, clay flue liners generally do not have molding seams. It is possible that a groove or ridge was created by an imperfection in the die, which may have been mistaken for a seam. At any rate, it is clear that the cracks were longitudinal.

18. Richard D. Peacock, "Chimney Fires: Intensity and Duration," National Bureau of Standards, Center for Fire Research, *Fire Technology*, Vol. 22, No. 3, August, 1986.

19. Denis A. Brosnan & John P. Sanders III, "Fireplace Mortars," Clemson University, Center for Engineering Ceramic Manufacturing, Clemson, SC, July, 1990.

20. Nolan Mitchell, "Fire Hazard Test with Masonry Chimneys," *NFPA Quarterly*, National Fire Protection Assn., October, 1949.

21. Richard Peacock, *Thermal Performance of Masonry Chimneys and Fireplaces*, National Bureau of Standards, Center for Fire Research, NBSIR 87-3515, 1987.

Chapter 3:

Mechanisms of Thermal Damage to Clay Flue Lining

3.0 INTRODUCTION

Previous chapters have described the nature of masonry chimneys and clay flue lining and have explored the nature, thermal dynamics, and effects of chimney fires. It has been observed that clay flue lining is a product well-suited to the environment found in a chimney under normal operation. It has good resistance to the temperature conditions expected to result from operation of a residential type appliance and outstanding resistance to the corrosive and erosive effects of flue gases and moisture. However, like all ceramic materials, clay flue lining is subject to cracking and spalling from the thermal shock resulting from rapid or extreme temperature rise.

While normal operation of a residential appliance generally does not (and should not) result in the conditions necessary to result in thermal shock damage, a chimney fire is a dramatic departure from normal conditions. The inner surface of a flue liner is subject to a sudden and substantial increase in temperature, and exposure may continue for a relatively long period. Thermal gradients are likely to be developed through the liner wall sufficient to initiate thermal shock damage. It is common to find through-cracking and, occasionally, surface spalling of the flue liner following a chimney fire. A strong characteristic of cracks related to thermal shock is their longitudinal direction – the liner is most commonly found split lengthwise – and the crack frequently extends for the full length of the liner. Transverse or diagonal cracking is also found, but it is more common near the bottom of the flue and rarely found by itself. A longitudinal crack is nearly always present.

Having established empirically that clay flue lining does crack from exposure to chimney fire conditions, the purpose of this chapter is to explore more closely *how* and *why* such cracking occurs. While the approach of this chapter is not strictly analytical, it is an attempt to apply the fundamentals of thermal shock to the particular problem of clay flue lining. An examination of the mechanics of thermal shock will help clarify and explain the phenomena observed in the field.

Because the problem of thermal shock is endemic to the field of ceramics, there is substantial literature on its fundamentals and application to various shapes and materials. There has been very little written about the thermal performance of flue linings. Literature searches through the American Ceramic Society, FIREDOC, and other bibliographies turned up only two references, both of which are very old and strictly empirical. They are interesting from a historical standpoint and may be helpful in describing the conditions necessary for thermal damage, but the bulk of this analysis is from the application of basic principles to the general characteristics of clay flue lining.

Several experts in the ceramics field assisted in the preparation and review of this material. The Chimney Safety Institute of America wishes to thank Dr. Hayne Palmour of North Carolina State University in particular. Dr. Palmour provided numerous references and resources and helped explain the behavior of materials and shapes similar to flue lining. Since the performance of flue lining under chimney fire conditions is a virtually unexplored field, neither Dr. Palmour nor anyone else is responsible for any errors which future study may reveal.

3.1 THERMAL STRESS CONCEPTS

Nearly all materials expand when heated, and the amount of expansion is directly proportional to the increase in temperature of the material. An object that is heated to a uniform temperature and is not otherwise restrained will be free to expand in all directions, and no stress will result from the increase in temperature. If the object is restrained from expanding by any means, stress will be developed within the object in proportion to the restraining force.

If two separate objects identical in size, shape, and material are placed next to each other and heated to different temperatures, the warmer body will expand more and become larger in all dimensions. Because each object is free to expand in proportion to its temperature, there will be no stress between the two. However, if the two objects were glued together before they were heated, the expansion of the warmer half would

be restrained by the lesser expansion of the cooler half. As a result of this restraint, stress would develop at the joint between the two. The amount of stress would be in proportion to the difference in temperature. If the stress is greater than the strength of the bond between the two, the halves will break apart.

If the two objects were one continuous material with no joint between halves, stress would also develop and be distributed throughout the material in proportion to the temperature difference between the different portions. *Thermal stress* is the result of uneven heating of an object when different parts are at different temperatures. Under these conditions, a *temperature gradient* will exist between parts at different temperatures. Figure 3-1(a) illustrates a temperature gradient through a simple object – a flat plate extending uniformly in all directions. In this example, the object is being heated from the left side while the other side remains at ambient temperature. The straight line shows the temperature gradually declining through the cross-section of the material. The dashed line shows the *average temperature* through the material which in this case is exactly half way between the highest and lowest temperatures on the opposite surfaces.

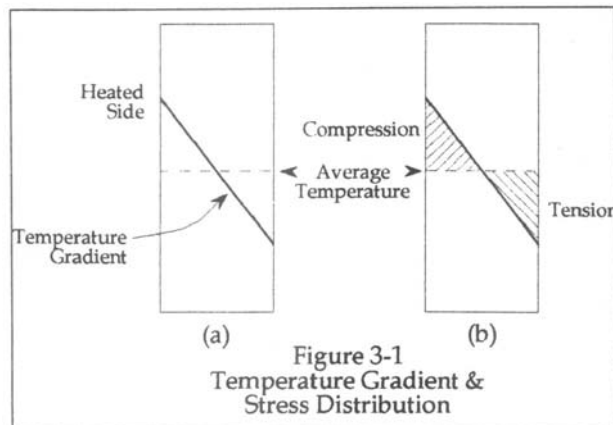

Any part of the object which is either warmer or cooler than the average temperature will be under stress. As shown in Figure 3-1(b), in part of the material the stress will be in the form of *compression* and part in the form of *tension*. The half of the object which is warmer will be under compression because it is expanding against the restraint of the cooler half. The cooler side will be under tension because it is resisting the expansion of the warmer half. At any point through the cross-section of the object, the amount of either tensile or compressive stress will

be in proportion to the temperature of that point compared to the *average* temperature of the entire object. In the example shown, stress would be greatest at each of the two opposite surfaces where the difference in temperatures from the average is greatest. Stress diminishes further inside the object, and there is no stress at the point where the temperature is the same as the average.

3.1.1 THERMAL STRESS RESISTANCE

Temperature gradients within objects are common, yet objects do not necessarily break from the resulting stress. Every material has a different ability to resist the effects of stress, and the amount of stress necessary to damage a material can be termed *failure stress*. “Failure” can take many forms, depending on the type of product and its use. For ceramic materials, which include burned clay products such as brick and flue liners as well as glasses, porcelain, and pottery, the most important modes of failure are *fracture* or cracking and spalling which is the breaking away of pieces of an object.

Like most materials, ceramics have a different failure stress under compression and under tension. *Ceramic materials are roughly four to eight times stronger under compression than under tension.*¹ Greater stress can be allowed to develop in material under compression without approaching the failure stress than in material under tension. Therefore, depending on the specific conditions, failure is more likely to be initiated in the part of an object under tension which, under a temperature gradient, will be the cooler portion. Although interior portions of a material can reach failure stress under tension, failure is more likely to begin at a surface.² Therefore, the study of the effects of thermal stress on ceramic materials tends to concentrate on the development of tension at the cooler surfaces or edges of objects.

The magnitude of stress necessary to cause failure is a function of certain properties of the material and the shape of the object. Different objects made of the same material, but formed into different shapes will have different abilities to resist the effects of thermal stress. The geometry of the material affects how heat is distributed within the object and the directions in which the forces of expansion are concentrated. The effects of object shape can be very complex, and a

complete discussion of the subject is beyond the scope of this report. However, the unique characteristics of hollow cylinders, the characteristic shape of flue liners, will be taken up in a later section.

Among the more important material properties affecting thermal stress resistance are the *thermal conductivity*, coefficient of thermal expansion, and Young's modulus (modulus of elasticity). The thermal conductivity determines how quickly heat will conduct through a material. If part of an object is heated, the heat will begin to spread out through the material, causing a change in temperature. Materials with a high conductivity will allow the heat to spread more quickly. Temperatures through the object will tend to be more even, with less temperature difference between hotter and cooler sections. All things being equal, less stress will develop in an object made of a material with a high thermal conductivity.

The *coefficient of expansion* determines the amount of expansion that will occur for a given degree of temperature change. Material with a high thermal expansion coefficient will expand more when their temperature changes. If an object made of such a material is heated unevenly with a temperature gradient, there will be a greater difference in the amount of expansion between the warmer and cooler portions. Under similar conditions, an object with a high expansion coefficient will develop more stress than an object with a lower coefficient.

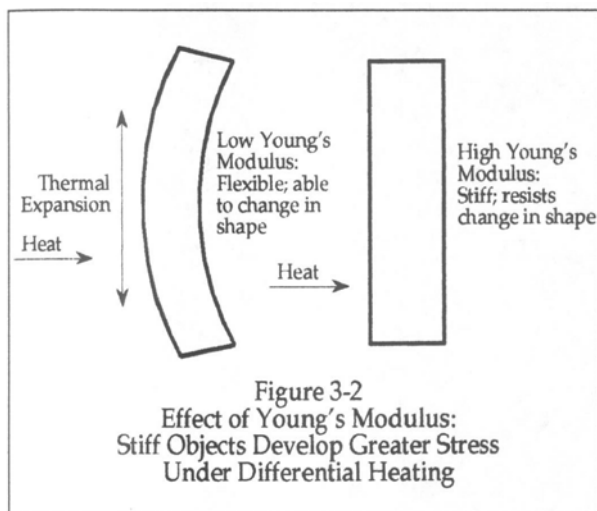

Young's modulus is an index of the stiffness of a material. Stiff materials (with a high Young's modulus) will resist a change in shape when subjected to a force. When an object is subject to

uneven heating, the different degrees of expansion would tend to make the object change shape. Flexible materials can accommodate this change in shape while stiff materials will resist, as shown in Figure 3-2. Therefore, more stress will develop in an object with a high Young's modulus.

Ceramic materials are fairly good conductors of heat. They do not have as high a thermal conductivity as most metals, but are better conductors than wood and most other building materials. Similarly, most ceramic materials have a lower coefficient of thermal expansion than most metals, but higher than other building materials. What distinguished the thermal stress resistance of ceramics from other materials is their stiffness. Compared to most metals or wood, ceramics have a much higher Young's modulus. Metals and wood, when subjected to uneven heating, are able to distort to some extent and relieve much of the thermal stress. Ceramic materials, in contrast, can distort very little without breaking. A temperature differential between different parts of a ceramic object will result in the development of a relatively large amount of stress. Ceramics are therefore more vulnerable to failure under conditions of thermal stress than most other building materials.

Ceramics are well known for their ability to withstand high temperatures. All ceramics are formed at high temperatures, and many ceramic products (such as clay flue liners) are chosen specifically for use in environments where temperatures will be high. It may seem paradoxical that a material well-suited to high temperatures is also vulnerable to thermal stress failure. *The answer lies in the fact that ceramics perform well at high absolute temperatures, but they may fail under a temperature differential when part of the object is significantly hotter or cooler than other parts.* The study of thermal stress in ceramic materials concentrates therefore on the conditions of exposure likely to create such a differential.

3.1.2 STEADY STATE CONDITIONS

When the amount of heat flowing into a material is equal to the amount flowing out, the condition is called *thermal equilibrium* or *steady state*. When conditions are at steady state, the temperatures throughout the material are not changing. For a monolithic material heated from

one side, the temperature gradient through an object will be a straight line as shown in Figure 3-3(a).

Note that under steady state conditions, the average temperature of the object (shown by the dashed line) will be exactly half way between the highest and lowest temperatures on the opposite surfaces. Half of the object will be warmer than average and therefore be under compression, and the other half will be cooler than average and under tension. The amount of compressive stress on the warm surface and the amount of tensile stress on the cooler surface will be equal.

3.1.3 TRANSIENT CONDITIONS

When the temperature of one or more parts of an object is changing, the conditions are said to be *transient* rather than steady state. Under transient conditions, the temperature distribution within an object and therefore, the amount of stress (and the likelihood of failure) is a function of both *time* and the *rate of heating*.

Heat does not conduct immediately through a material. When heat is applied to one side of an object, the temperature of the heated surface rises quickly, but there is a delay before the heat reaches deeper into the object and penetrates to the other side. Because the temperature of the material closer to the heat source is rising more quickly than the material further away, the temperature gradient during transient conditions is not a straight line but is a parabolic curve. Figure 3-3(b) illustrates a theoretical transient temperature gradient curve. Note that the average temperature of the object is not exactly between the two extremes of temperature at the cool side.

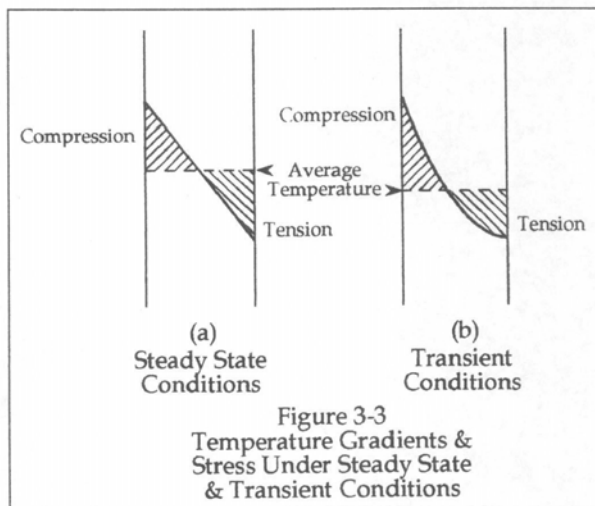

Figure 3-3
Temperature Gradients & Stress Under Steady State & Transient Conditions

When the temperature of one side of an object is rising, the compressive stress at that surface is greater than the tensile stress on the opposite cooler surface.

The shape of the temperature gradient curve (and therefore of the distribution of stress) changes with time. As heat is conducted through the object, the portion of the object further from the heat source will begin to rise in temperature and to “catch up” with the hotter surface. The overall temperature difference between the hottest and coolest locations will become progressively less, and the parabolic curve will gradually become closer to a straight line. This process will continue until steady state conditions are attained.

Figure 3-4 shows two examples of the changes in temperature and stress distribution with time. The upper half of the figure (a-c) represents an object heated quickly up to a particular temperature. The lower half (d-f) shows an object heated more slowly up to the same temperature. In the more quickly heated object, the hot side temperature rises quickly while the cool side temperature lags behind. There is both more compressive stress on the hot side and more tensile stress on the cool side than for the more gently heated object. Eventually, both objects will reach steady state conditions and will have identical straight-line temperature gradients and stress patterns, but at any time prior to steady state, an object subjected to a more rapid temperature rise will be subject to greater stress and a greater likelihood of failure.

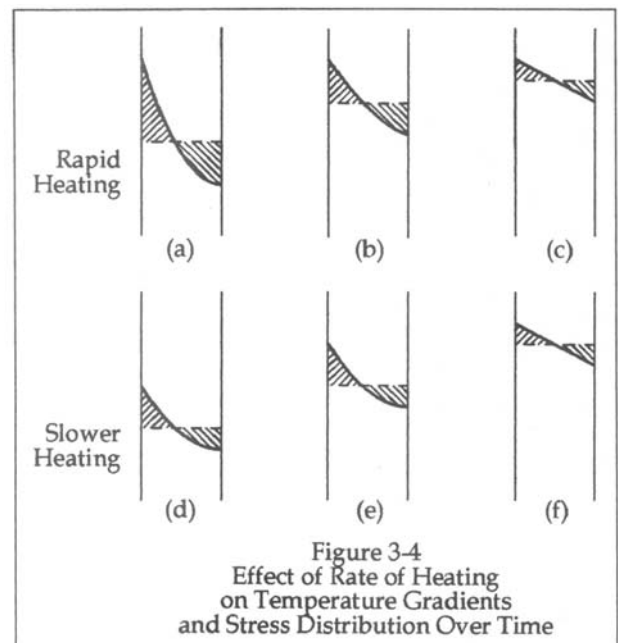

Figure 3-4
Effect of Rate of Heating on Temperature Gradients and Stress Distribution Over Time

3.1.4 THERMAL SHOCK CONDITIONS

The term *thermal shock* is used to describe the stresses resulting from a sudden transient temperature change. Because different materials and different shapes respond differently to thermal stress, there is no single temperature or temperature rise which defines thermal shock. Thermal shock is simply any rapid change in temperature which causes the development of severe stress within an object. If thermal shock is sufficiently extreme, the object will fail in one form or another.

Figure 3-5 illustrates the progression of stress at various times during an incident of thermal shock. The situation shown is an approximation of the conditions that can occur during a chimney fire when the inner surface of a flue liner is suddenly exposed to rapidly increasing temperature. In Figure 3-5(a), the left surface has just been suddenly exposed to extreme heat. The temperature of the surface has risen dramatically, but the material a short distance under the surface has barely begun to heat up. The temperature on the opposite surface has not changed at all. The average temperature of the material has risen just slightly higher than the original temperature.

During this initial stage of thermal shock, the hot surface is under a large amount of compressive stress. The surface “wants” to expand greatly but is restrained by the much cooler material immediately adjacent. As a result, a plane of shear stress may develop just under the surface at the boundary between the very hot and much cooler material. If this stress is severe enough, spalling of the hot surface will occur. The surface layers will literally slough off the substrate in flat leaves, leaving a crater.

Because the average temperature of the object does not initially rise very much, the cooler side is initially under little tensile stress, but in Figure 3-5(b) heat has begun to conduct through the material, and more of the inner material is rising in temperature. As a result, the average temperature of the object is beginning to rise significantly. The surface of the cool side, which still has not begun to warm up, is under increasing tensile stress.

In Figure 3-5(c), a significant amount of heat has penetrated the object, and the temperature of the cooler surface is just beginning to rise. The average temperature has risen to its highest point above the temperature of the cool surface, and tensile stress on this surface is at its maximum. It is at this point that the risk of fracture, initiated on the surface of the cool side, is greatest. If the amount of tensile stress developed on this surface exceeds the ability of the material to “hold itself together,” failure will occur. For most brittle materials such as clay flue lining, the strain energy released by the inception of cracking will be sufficient to propagate the crack through the entire thickness of the material. In other words, the failure will likely be catastrophic once enough stress has developed to initiate a crack.

In Figure 3-5(d), the temperature of the hot side has essentially reached its maximum. It is no longer rising, but heat continues to be conducted through the material, and the total temperature difference through the object is beginning to narrow. The temperature gradient curve is beginning to flatten out, and there is no longer as great a difference between the average temperature and that of the cool surface. The risk of fracture is decreasing because the tensile stress is decreasing.

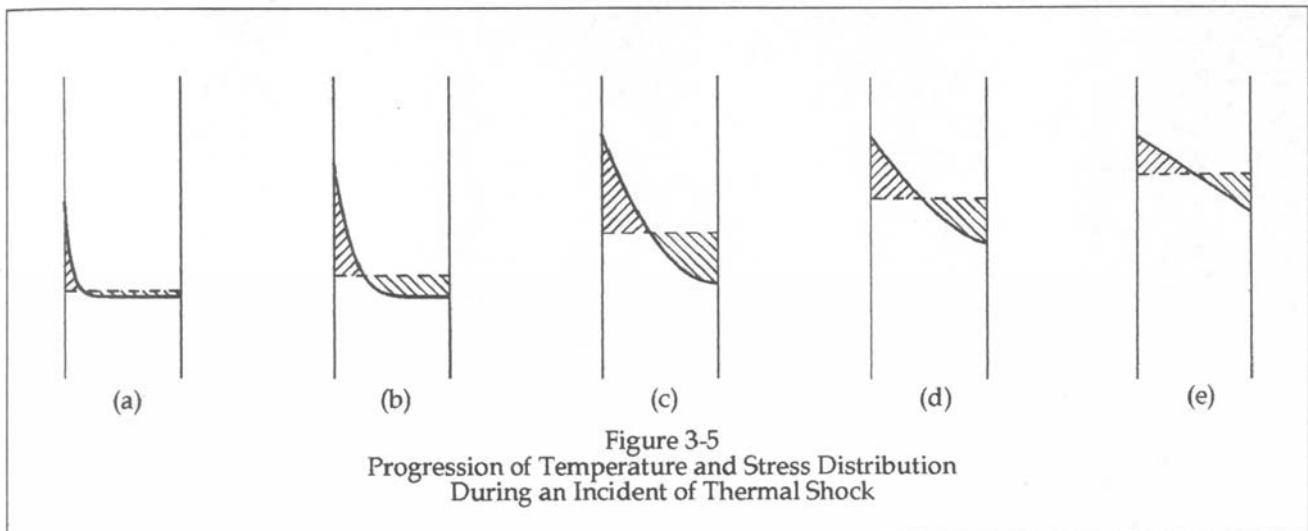

In Figure 3-5(e), steady state conditions have been attained. The amount of heat still flowing into the hot side is equal to the heat being lost off the opposite side. The temperature gradient curve has become a straight line, and the compressive and tensile stresses on opposite sides are equal. The material is much hotter than it was before the incident of thermal shock began, but the greatest danger of failure is past. If the object has survived the earlier peaks in thermal stress, it should, theoretically, continue to survive indefinitely under steady state.

Thermal shock is the result of a dynamic relationship between time and exposure conditions. Even a large change in temperature over a relatively long period of time may not create sufficient stress to cause failure. On the other hand, a relatively small change in temperature over a short period of time may generate failure stress. The character and location of stress changes during an incident of thermal shock. During the early stages of exposure, the focus of stress is on the hot compressive side of an object. Spalling of the hot surface is likely to occur quickly after exposure begins. In contrast, the development of maximum tensile stress is not immediate, but occurs at some intermediate time after the onset of high temperature exposure. There is therefore likely to be some delay before a tensile fracture failure occurs. After reaching their respective peaks, both compressive and tensile stress will decline as exposure continues.

3.2 SHAPE EFFECTS: HOLLOW CYLINDERS

The examples in the previous section all considered an object of “generic” shape. As the figures suggest, they are most directly relevant to an infinite flat plate – an object of specified thickness extending uniformly in all directions. As general principles, the trend outlined above are applicable to all sizes and shapes of objects, but the particular geometry of an object being heated will significantly influence the way that temperature gradients and stress distribution are developed and the manner of failure.

Clay flue linings are neither flat nor infinite. They are hollow cylinder with either a round, square or rectangular horizontal cross-section.

They have a finite length and therefore have ends and edges, the effects of which have not been considered so far. In order to relate the principles of thermal shock to the conditions and patterns of failure found in the field, we must examine the peculiar performance of hollow cylinders.

3.2.1 TEMPERATURE GRADIENT THROUGH CYLINDER WALL

Under steady state conditions, the conduction of heat through a flat plate specimen is simply a function of the thickness, and the temperature gradient curve is a straight line with a uniform slope. At any point through the material cross-section, the amount of material that needs to be heated is the same. The amount of material at the outer surface of a cylinder is greater than the amount of material at the inner surface (as it is at every point in between), so for any given amount of heat flow through the cylinder wall the heat is progressively “spread out” by the increasing amount of material to be heated. In addition, the greater surface area at the outer surface means that for any given set of heat transfer conditions more heat will be lost from the outside surface of a cylinder than from a flat plate.

The rate of temperature drop through the material cross-section is not uniform, but is a function of the logarithm of the ratio between the inner radius and outer radius. For any given set of material properties, heat transfer conditions, and heat flow, the temperature drop from the hot side to the cool side of a cylinder will be greater than for a flat plate. The amount of tensile stress developed at the outer surface will also be greater.

3.2.2 DIRECTIONS OF THERMAL EXPANSION

When the interior surface of a hollow cylinder is heated, the strains resulting from thermal expansion are directed (and re-directed) differently than those in a flat plate specimen. As with flat plates, the heated material expands in all directions in proportion to its rise in temperature. In a cylinder, the three dimensions of expansion are axial (parallel with the axis of the tube, up and down), radial (outward from the center), and circumferential (around the circumference of the tube). Figure 3-6 illustrates these directions.

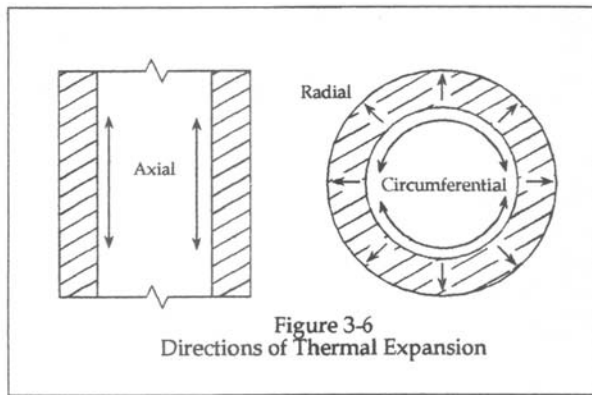

The radial and axial strains behave more or less like their counterparts in a flat plate. The radial expansion exerts a compressive force toward the outside surface, but the amount of stress created is relatively small. The axial expansion of the inner material against the resistance of the cooler outer material creates a tensile stress on the outside similar to that of a flat plate although it has a unique effect at the end of the cylinder.

However, the circumferential strain is unique to hollow cylinders. In Figure 3-6, note that the expansion of the inner surface, which forms a closed ring, is directed against itself – equal and opposite compressive forces are distributed around the inner circumference. While the hot surface of a flat specimen can try to get longer to accommodate the expansion of the material, a closed ring cannot get longer. The only way that a ring can respond to the linear expansion of its surface is to get larger in circumference and therefore larger in diameter. The only problem with this scheme is that the cooler rings of material further from the inner surface do not (depending on the temperature gradient) necessarily expand to the same degree and may not assume the diameter necessary to accommodate the new diameter of the inner material. The inner material is, in effect, trying to “burst out” from the restraint of the outer material. The result is stress in the outer portion of the cylinder wall, with the greatest stress at the outer surface. *This is a form of tension called hoop stress or tangential stress – a force tending to pull apart the outer surface in the direction of the tangent with the surface.*

In an infinitely large body, there are no edges and it cannot change in shape in response to the strains of expansion, but the free ends of a finite hollow cylinder are not restrained by surrounding material. The expansion of the hot inner walls

tends to force the cooler walls outward. In addition, axial expansion of the interior walls tends to make the inside of the tube longer than the outside. The combined result of these forces is to make the ends of a finite hollow cylinder flare outward (Figure 3-7). This results in even greater tangential stress at the ends of the cylinder. For a hollow cylinder uniformly heated from the inside surface, the location of maximum stress for any given temperature difference will be on the exterior surface at the ends of the tube.

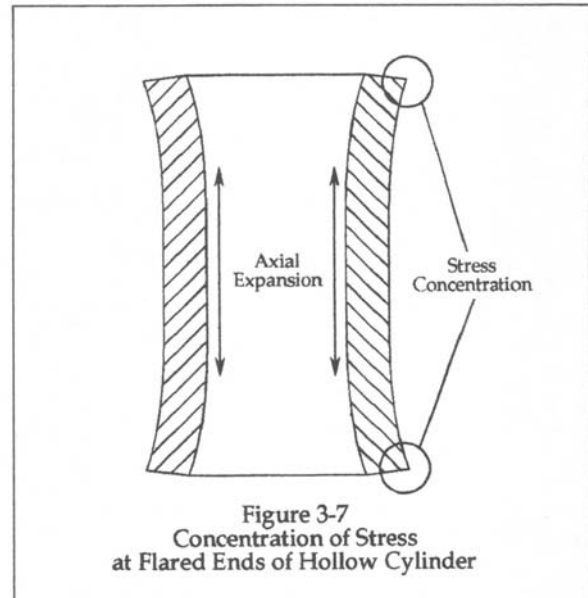

3.2.3 DIRECTIONS OF THERMAL CRACKS

There is another important implication of the peculiar behavior of a hollow cylinder under thermal stress. In a flat plate specimen, the direction of any crack which occurs is not influenced by the shape. It can extend in any direction, depending on details of the material microstructure. In a hollow cylinder, however, the predominance of tangential stress means that the initial crack must nearly always be longitudinal, i.e., parallel to the axis of the tube. *The only way that the stress created by the outward-expanding inner material can be relieved is by splitting of the outer surface, as shown in Figure 3-8(a).*

The maximum stress in the tube is located at the flared ends, so *if the failure stress of the material is exceeded anywhere during an incident of thermal shock, it will be at the end and the most likely place for a crack to be initiated is at an end.* Once an initial longitudinal crack is created, subsequent splitting is likely to be a continuation

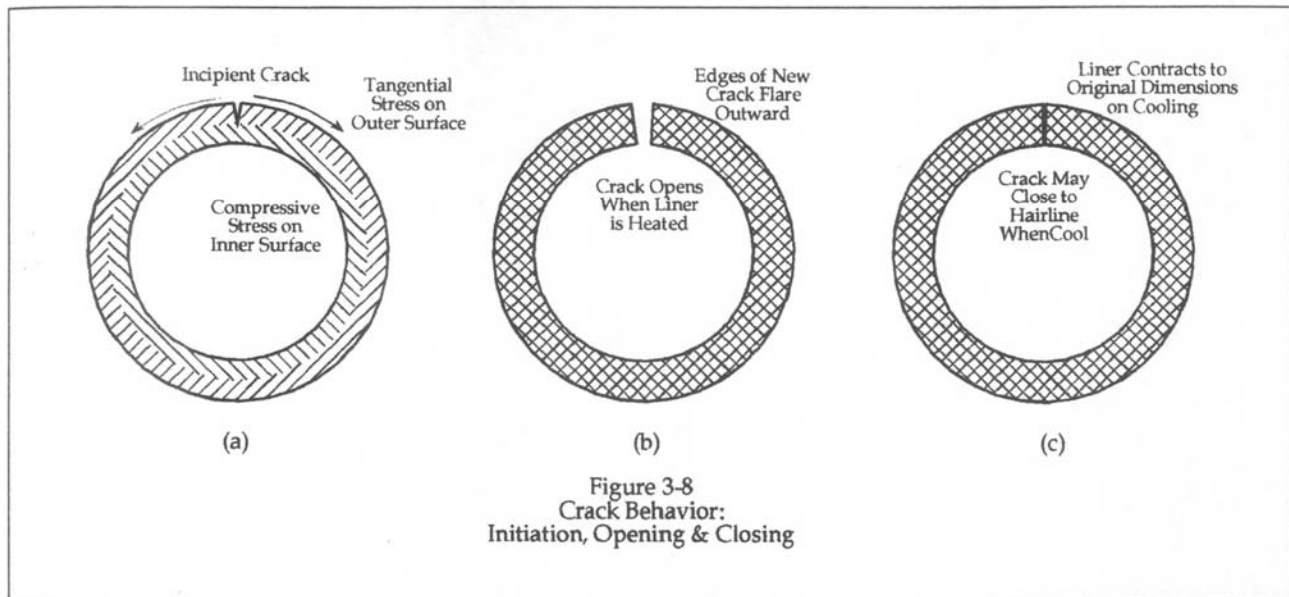

Figure 3-8
Crack Behavior:
Initiation, Opening & Closing

of the original. The occurrence of separate short splits around the circumference is unlikely. The sharp edge of the crack acts as a stress concentrator, and the strain energy released by the fracture of a brittle material will usually be sufficient to extend the crack through the full thickness of the cylinder wall. The most common and predictable mode of failure for a ceramic cylinder is (both empirically and theoretically) a single longitudinal fracture extending from an end.

Although a crack will nearly always start at an end and penetrate the entire wall thickness, it will not necessarily extend for the full length of the cylinder immediately. Since the greatest stress is at the end, the lesser tangential stress in the middle of the object will not necessarily be sufficient to continue propagating the crack. However, continued heating and increased development of stress will work to extend the rift. It is not unusual to find a limited crack running only a short distance from an end, but full-length cracks are perhaps more common.

3.2.4 OPENING AND CLOSING OF CRACKS

Once the overriding tangential stress has been relieved by the development of a longitudinal crack, the cylinder is no longer closed. Instead, it behaves as a split ring which shares characteristics of both cylinders and flat plates. As in a cylinder, the temperature drop through the material is logarithmic, and the inner surface expands relative to the outside. However, two new edges have been created by the crack, and

they are likely to flare outward as did the ends of the original cylinder. As a result, the crack is likely to “open up” when the inner surface is heated, and a considerable gap may develop between the edges, as shown in Figure 3-8(b).

When the specimen is cooled back to its original temperature, the material will again contract. The tangential stress caused by the differential temperature of the inner and outer surfaces will ease, and the flared edges of the crack will tend to come back together. The crack is likely to completely close. If the edges match up perfectly, the cylinder may resume its original dimensions with only a thin hairline crack to testify to the occurrence of thermal shock, as shown in Figure 3-8(c).

3.2.5 SECONDARY CRACKS

The occurrence of a primary longitudinal crack does not preclude the development of additional cracks which may also be longitudinal, transverse to the axis, or diagonal. A great deal of tangential stress is relieved by the ability of the crack to widen, but severe thermal shock may cause the development of failure stress at other locations around the circumference and further longitudinal cracks. Axial expansion is not relieved at all by the initial longitudinal crack, and it will cause the same tensile stress on the outside surface as it would on a flat plate. Even microscopic sharp uneven edges tend to concentrate stress and function as “crack starters,” so any transverse or diagonal cracks that develop will almost certainly emanate from some point or points on the original crack.

In order for any type of cracking to occur, the failure stress for the material must be reached. Because of the predominance of tangential stress in hollow cylinders, however, the threshold of thermal shock necessary to create longitudinal cracking is much lower than from cracking from the other stresses. The degree of shock either in the form of overall temperature difference or rapidity of heating must be much greater to initiate transverse cracking even after a longitudinal crack has occurred. Such crack patterns may develop if conditions are severe enough, but they are nearly always secondary to the initial longitudinal crack.

Information on the development of stress in hollow cylinders with rectangular cross-section is apparently not available. Undoubtedly, the mathematics of stress calculation for such shapes is more complex than for simple round cylinders and probably must include allowance for the aspect ratio of the sides. However, the effect of differential circumferential expansion of the inner material is probably still the dominant effect. As with round cylinders, the limiting failure stress is the tension developed tangential to the outer surface, and the primary mode of failure will still be longitudinal fractures beginning from the ends. Because stress may be concentrated at the rounded corners, which also form a "hinge" between adjoining sides, fracture may be more likely to occur at or near the corners. This possibility is not fully supported by field observation, however. Rectangular chimney liners cracked by thermal shock frequently show fractures running up the face of a side, not just at the corners.

3.3 DISCUSSION OF APPLICATION TO FLUE LINERS

The above principles on thermal shock and the behavior of hollow cylinders provide the basis for understanding the performance of clay flue lining under chimney fire conditions. Application of these principles helps to explain many of the effects which have been observed to result from actual chimney fires in both the field and the laboratory.

3.3.1 SEVERITY OF CONDITIONS NECESSARY FOR DAMAGE

In order for thermal shock failure to occur, a substantial temperature gradient must be developed through the wall of a flue liner. As

discussed in Chapter 2, during normal operation there will be a relatively small temperature gradient which, empirically, is usually not sufficient to develop failure stress. In data reported by the National Bureau of Standards,³ during low fire operation, the temperature difference between the flue gas and outer liner wall never exceeded 100°F and was usually less. Even during tests involving the high fire mode of normal operation, the estimated temperature gradient through the liner wall was not greater than 200°F.

During overfire testing, which actually represents abnormal and abusive operation, the maximum temperature difference between flue gas and outer wall in one test was about 850°F during transient flare-ups. As noted by Peacock, the inner wall surface of the liner would be significantly cooler than the flue gas temperature, so the net temperature gradient through the liner has been estimated at around 500 to 600°F at the most extreme flare-up. In later tests conducted with a different chimney,⁴ overfire testing with a similar flue gas temperature resulted in only an estimated 450°F temperature gradient through the liner. Even though these conditions created relatively large temperature gradients through the liner walls, the flue liners were not observed to crack during any of these overfire tests.

During normal and even overfire operation, the flue surface is heated only by the flow of hot gases past its surface. The highest gas temperature in the flue will be at its center and will decline nearer the liner surface. The rate of heat transfer to the liner, while potentially high, is not extreme, but during a chimney fire the liner is heated directly by combustion at or near its surface. The highest temperature in the flue may not be in the center where flue gas temperatures are traditionally measured, but closer to the liner surface instead. Consequently, both the temperature to which the liner is exposed and the rate of heat transfer are likely to be higher during a chimney fire even for equivalent measured flue gas temperatures. The actual inner surface temperature will be closer to the flue gas temperature than during normal or overfire operation.

Flue gas temperatures are significantly higher during a chimney fire than during normal operation. Peacock⁴ has recorded a maximum of 2500°F in one very severe test and 2000°F in a

masonry chimney. Peak temperatures during free-burning fire conducted by Peacock and others typically have fallen within the range of 1700 to 2000°F. Study of slower chimney fires has been very limited. Stone⁵ recorded flue gas temperatures of around 1400°F, but liner wall temperatures may have been higher because of glowing combustion on the surface.

There are no published studies which report the temperature of the inner surface of the clay flue lining during a chimney fire, so the temperature gradients developed through the liner must be estimated by interpolation between the outer surface and flue gas temperatures. A more detailed discussion of these estimates is included in Chapter 2. In the two masonry chimney fires conducted by Peacock, the probable maximum temperature difference ranged from 1000 to 1300°F for the shorter but more severe fire and between 700 and 850°F for the longer fire. Significantly, the flue lining of both chimneys was found to be cracked after both tests.

The conditions present during a chimney fire are far more conducive to the development of thermal shock failure than the conditions during normal or even high-fire operation. However, these data do not clearly define a threshold of time and temperature gradient necessary to produce cracking.

Since no known recent investigation into the critical failure stress of clay flue linings has been made, the exact conditions necessary for thermal shock failure cannot be fixed with certainty. Two published studies have been identified (both very old) which attempted to correlate thermal cracking with the degree of exposure. In the first study, published in 1927, the plan of investigation was crude by modern standards, and the methods of temperature measurement were questionable. In the second study, from 1940, the methodology was considerably improved, but the reporting of data was sketchy. Furthermore, it is not known how the materials and manufacturing control of the tested linings compare with currently produced linings. Any conclusions about the thermal stress resistance of clay linings based on these studies must be tenuous at best.

The 1927 investigation⁶ was made in response to a complaint about broken flue lining serving a coal burning boiler which operated with an excessively high flue gas temperature by modern

standards. The complaint prompted Salt Lake City officials to suspend approval of clay flue linings until further information on their likelihood of failure could be developed. In order to develop this better understanding, the authors, Hart and Clark, subjected several samples of flue lining to flue gases from wood fires. In some cases the tiles were tested exposed to air, and in other tests the tiles were encased in a short brick "chimney." In exposed tests, the flames from the fire were allowed to impinge on the tile. In the tests using a chimney, a short length of pipe separated the fire from the flue.

In all tests, the flue linings were subjected to a severe temperature rise as a function of time. For the open air tests, the measured flue gas temperature rose from 150°F to 700°F in about three minutes, the tiles were observed to crack when the temperature difference between the flue gas and ambient air was 472 to 622°F. Because flames impinged directly on the tiles, it is likely that the surface was bathed in significantly higher temperatures than those reported.

For the simulated chimney tests, the rate of flue gas temperature rise tended to be less but still substantial, averaging between 80 and 120 degrees per minute at the time of liner failure. Temperature differentials (flue gas to tile exterior, as measured) at the time of failure for most of the tiles were between 450 and 550°F, although one round tile survived until an 850 degree differential developed. As noted above, the instrumentation and temperature measurement were somewhat less sophisticated than would be used today.

Hart and Clark then compared these observations with time/temperature curves from several actual chimneys with a variety of appliance types. They found that, while there was good agreement between the actual chimney temperatures and the tests conducted, flue linings did not often crack in actual service. They suggested that the discrepancy was due to unrealistic conditions in their test setup. They concluded that clay flue lining was sufficiently durable in appliances for which high operating flue gas temperatures were the only consideration. However, they noted that soft coal produces large amounts of soot and that a chimney fire would create conditions more severe than produced in their tests. They therefore called for the development of more thermal shock resistant lining for use in areas

where soft coal was the predominant fuel.

This study appears to confirm that liner fracture from non-chimney fire conditions is possible, but infrequent. However, the nature of the liners tested, compared to modern products, cannot be examined, and the test procedure employed was admittedly primitive. It is possible that more shock-resistant lining has indeed been developed in the last 60 years and that improved manufacturing controls have produced more consistent products. Therefore, no real conclusions can be derived from this study about temperature and time conditions needed to cause fracture of clay flue lining.

The second report,⁷ from 1940, was conducted primarily to test the performance of alternative base materials for clay flue lining. As background for the study, the authors note that "Chimney-flue liners, after one or two chimney fires, are usually only pieces of liners in place in the chimney, and therefore they are not what the building codes have specified." Their plan of study included construction of a number of instrumental test chimneys with liners of both conventional and candidate materials. The chimneys were coated with soot from incomplete combustion of oil, and then a chimney fire condition was created. This investigation thus held great promise for shedding light on the conditions needed for thermal shock failure.

Unfortunately, the authors report very little of the resulting data. They do note that readily available commercial linings failed after several "chimney fire" cycles. A chart of flue gas temperatures for several liners shows peaks of between 400 and 800°F immediately before failure. If the temperatures of the exterior of liners were recorded, they are not reported. If, in fact, the coating of oil soot was ignited to produce the "chimney fires," the liner surface temperature may have been greater than the reported flue gas temperature, but nothing is mentioned in this respect. Little information about the performance of clay linings can be developed from the published information.

One other series of tests need to be mentioned in this connection. In the late 1940's, the National Bureau of Standards conducted an extensive study of many facets of chimney safety, and results were reported by Mitchell in 1949.⁸ The primary focus of these studies was on temperature

development and on ignition of framing surrounding chimneys. However, many of the test chimneys were subject to "heat shock" tests which involved raising flue gas temperatures to the range of 1400 to 1800°F over a 30-minute period. All of the liners subjected to these tests were found to be cracked at the conclusion.

Mitchell concluded that liners tightly encased with mortar between the liner and chimney wall were more likely to cause coincident cracks in the chimney wall. Other than this observation, no further data is reported about conditions relating to liner failure.

With the lack of hard evidence relating liner failure to specific exposure conditions, it is difficult to draw conclusions about the likelihood of failure during various modes of operation. It is clear, both from theory and observation, that thermal stress failure is most strongly correlated with the rapidity of temperature rise rather than any particular flue gas temperature. It is virtually indisputable that chimney fires have the strongest potential for rapid temperature rise on the flue surface and frequently develop temperature gradients well in excess of those from normal or even overfire operation. *From the evidence of fracture during laboratory chimney fires, it is clear that temperature gradients of 800°F or greater will consistently crack clay flue linings.*

At the other extreme, it is equally clear that normal operation (which involves relatively gradual changes in temperature with gradients ranging to 100°F or so) does not frequently lead to failure. It is much less clear whether or not overfire conditions can or frequently do result in liner failure. Old and relatively imprecise testing of flue liners of unknown quality suggested that temperature gradients from 400 to 500°F could cause cracking. More modern overfire testing has produced temperature gradients in this range, but liner cracking has not been observed.

This is an area where further research would be beneficial, both for the development of improved lining products and for the diagnosis of the cause of cracking found in the field. If the mode of operation stays within the bounds of normal service, the likelihood of thermal stress failure must be rated very low. If episodes of overfire operation occur, the possibility of thermal shock damage is increased, but if a chimney fire occurs, the possibility of failure is near maximum. In the

absence of evidence to the contrary, *if a chimney fire is known to have occurred, and damage consistent with thermal shock is present, it is reasonable to conclude that the damage was caused by the fire.*

3.3.2 SEVERITY OF CONDITIONS NECESSARY FOR DAMAGE

A number of commonly observed characteristics of liner damage in the field can be reinforced and explained with reference to principles of thermal shock. Two modes of liner failure can be associated with chimney fires – cracking and spalling. Of the two, cracking is by far the more common. Spalling occurs in a small minority of fires and is usually found in conjunction with cracking.

When spalling occurs, it is related to very intense usually short-duration chimney fires or isolated areas of very intense combustion within the flue. It is most likely to develop early in the fire during an extremely high initial rate of heat transfer into the relatively cool liner. Under these circumstances, the temperature gradient curve can be very steep on the hot side. The inner wall will be under a great deal of compression even though substantial tension has not yet developed on the outside. Significant shear stress can develop at the boundary between the thin, very hot inner layers and the adjacent much cooler material. Spalling occurs when this shear stress is sufficient to cause layers or flakes of surface material to separate from the underlying material. Following a very severe chimney fire, these flakes of liner material may be found at the bottom of the chimney, and some sections will be cratered as if they had been gouged with a chisel.

When spalling is found, it is sometimes present throughout the flue. More commonly, however, it is found in one or two isolated areas. These were zones of unusually intense combustion during the fire. Often, the reason for the intense combustion was an air leak into the flue in the immediate area. During a fire, the high draft (negative pressure) within the flue will aggressively pull air in through any such leaks. A jet of flame, playing on adjacent walls of the flue, can result. This localized stress on the liner surface can lead to spalling.

While spalling can conceivably be the only results of a very intense but short fire, it is more common to find only cracking, and when spalling

is found, it is usually in conjunction with more extensive cracking. Spalling may occur early in the fire during the initial sudden rise in temperature on the flue surface, but most fires last long enough so that heat will continue to conduct through the liner, leading to progressively greater tensile stress on the liner exterior and progressively higher risk of fracture.

Because both the shape and magnitude of the temperature gradient curve changes with time, the maximum tensile stress on the outside of the lining will be reached after some period of time. There may therefore be a noticeable delay from the onset of a chimney fire until initial failure of the liner, and different parts may crack at different times. Reports of homeowners who have experienced fires are consistent with this prediction. When cracking sounds are noticed, they are usually reported to begin occurring from about 30 seconds to several minutes after the fire was first detected. Frequently, homeowners who have quickly closed the air supply to the chimney report that sharp cracking sounds continued well after the fire itself had been limited. This suggests that either the heat retained in the chimney from the intense fire or from remaining smoldering combustion was still propagating through the liner and gradually approaching the temperature gradient needed for failure. This means that early detection and action to curb a chimney fire does not eliminate the possibility of thermal shock cracking, but it may minimize the overall severity of the damage.

Whatever the generally desirable properties of a material, it is apparent that it will be less able to resist the effects of thermal shock when it is formed into the shape of a hollow cylinder. For flue liners, a generally cylindrical shape is obviously necessary to form a flue gas conduit, but this makes the material more vulnerable to the development of tensile stress than would the same material in the form of flat plates. Circumferential expansion of the innermost material during transient heating translates into hoop stress on the exterior surface and causes splitting under conditions that an equivalent flat plate would be more likely to withstand.

This does not imply that cylindrical flue liners are unsuitable for their intended purpose or that they should somehow be assembled out of flat sections. As discussed extensively above, the bulk of available evidence indicates that, under

conditions that normally and properly occur in chimneys, clay flue lining remains intact and able to perform its function of containing the products of combustion. The conditions encountered during a chimney fire are, both by definition and degree, beyond the range of intended service for all residential lining materials. It may also be true that the thermal shock produced by a chimney fire would be sufficient to cause failure of flat samples as well. The advantages during normal operation of a smooth cylindrical surface with a minimum of joints almost certainly outweigh its disadvantages during a chimney fire.

The shape of a clay flue lining does have important implications for the recognition of thermal shock damage as caused by a chimney fire. The predominance of tangential stress means that the initial crack in any liner section must, almost without fail, be longitudinal. *As discussed in section 4.2, the only way that this stress can be relieved is for the cylinder to split open from the outside and parallel to the axis.*

This is one area where empirical observation agrees most strongly with theoretical prediction. A signal characteristic of the damage observed after the occurrence of a known chimney fire is the presence of longitudinal cracks in the liner. Transverse cracking may also be present, particularly toward the bottom of the chimney, but never without the presence of longitudinal cracks. The association of longitudinal cracks with chimney fires is not based solely on field observation. In *all* laboratory studies of masonry chimney fires, the damage reported conforms to this pattern.^{4, 7, 8} These reports may be particularly significant because the chimneys or linings were built specifically for the tests and were not subjected to other forces which might be confused with the effect of the chimney fires. The characteristic effects of thermal shock can be readily demonstrated outside of a chimney by burning several sheets of newspaper within a lining propped up on bricks.

The correlation of longitudinal crack orientation with thermal shock is so strong that its existence is sometimes taken as evidence, by itself, that a chimney fire occurred. Such a generalization is probably too strong since it cannot be stated that other forces cannot also cause longitudinal cracking. However, when forces external to the liner can create stress in a number of directions, it should be clear from ceramic theory that thermal

shock damage is most likely to start with a longitudinal crack. When evidence of a chimney fire exists in the absence of clear evidence of other forces, it is reasonable to conclude that longitudinal cracking is the result of the fire.

The greatest tangential stress is concentrated at the ends of hollow cylinders, so the most likely place for a crack to start in a flue lining is at an end. This aspect of theory also conforms to field observation. Most commonly observed chimney fire damage consists of longitudinal cracks running the full length of each damaged liner section. This is not surprising since the stress present throughout a section during a chimney fire is likely to be sufficient to continue any cracks initiated at an end. However, it is not unusual to find cracks which start at an end, but do not run the full length of the section. Thermal shock-related cracks are rarely found "hanging" midway up a liner section without connection to an end.



Figure 3-9. In this photograph of a demonstration chimney fire, a clay flue liner, its interior coated with tar, has been ignited to simulate a chimney fire. Notice the severe crack at the near corner and the flame escaping the confines of the liner.

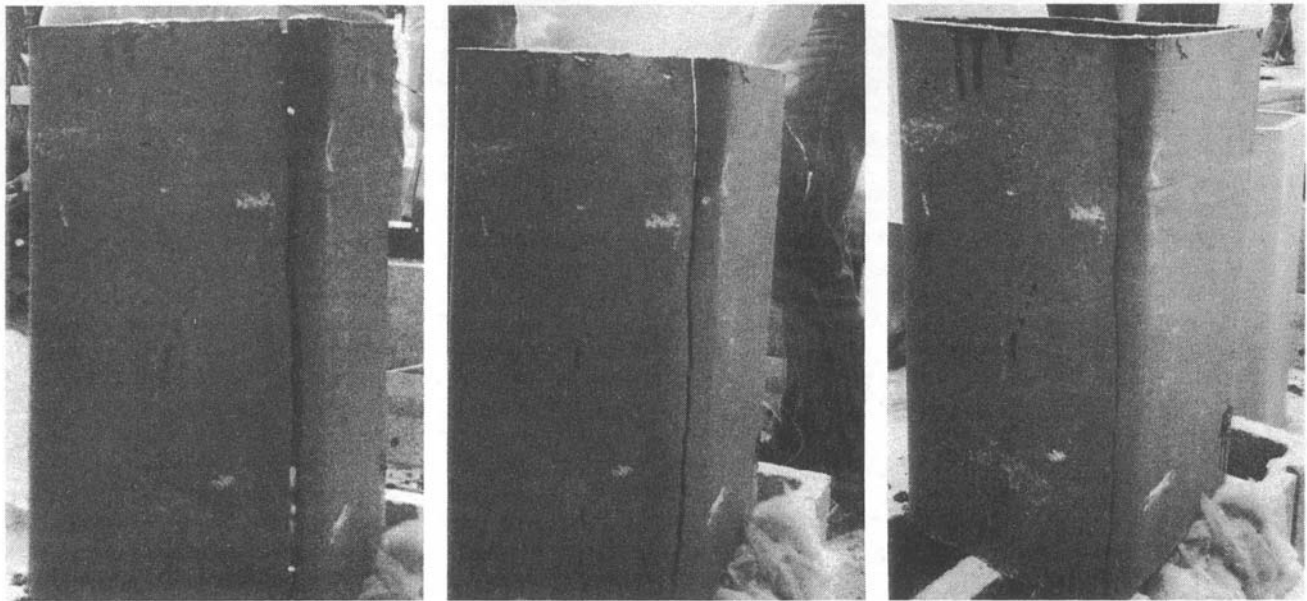

Figure 3-10 a,b,and c. A sequence of three photographs of a clay chimney tile during a cool-down period following a demonstration chimney fire. Note that the crack of 3/8 to 1/2-inch immediately following the fire closes 3/16 of an inch in the second photograph and is completely closed in the third photograph when the liner has cooled.

As discussed in this chapter, chimney fires tend to crawl up the flue on an advancing flame front, and peak temperatures are greater in lower sections. Heat given off by the fire below can warm the upper sections before the most intense part of the fire reaches them. Some fires may be limited or extinguished before they fully involve the upper sections. Thus the severity of thermal shock toward the top in many cases is less than that at the bottom, but it is still much greater than during more normal operation. This conforms to the general but not universal observation that chimney fire damage tends to be more severe at the bottom than at the top of a chimney. In some cases, longitudinal cracking is confined to the lower sections with no damage to the upper sections. Because chimney fires have been known to involve only the top or to be more severe in later stages, a reversal of this usual damage pattern does not by itself rule out a chimney fire as a cause.

It is not unusual for longitudinal cracking to be found in every liner section from top to bottom of the chimney. However, when transverse cracking is present, it is more likely to be found near the bottom of the chimney. This is consistent with the fact that transverse cracking is secondary to the initial longitudinal fracture. In an unbroken liner, the tangential stress developed is much greater than the stress in other directions, and this stress must be relieved first by a longitudinal

fracture. There is likely to be a significant gap between the stress available to cause the initial crack and the stress needed to cause additional failure. Since thermal shock tends to be less severe nearer the top of the chimney, it is statistically more likely that conditions will exist sufficient to cause a longitudinal crack but not a subsequent transverse crack. On the other hand, it is more likely that thermal stresses will be great enough to cause both types nearer the bottom of the chimney.

Once cracks have occurred, they are likely to open when the liner is heated. Continued differential expansion of the inner circumference, compared to the outer, caused the newly exposed edges of the split liner to flare outward. The “jaws” of the resulting gap may become considerably separated. The opening of cracked liners under continued heating has been clearly observed in demonstrations conducted in the open air, with gaps of one-fourth to one-half inch common. Although different environmental conditions may limit the amount of opening, it is reasonable to expect the same phenomenon to happen to a cracked liner inside a chimney. However, liners which are built tightly into the chimney or backed up by mortar may be restrained from opening to a measurable width. Ironically, this restraint may lead to more extensive cracking as the inability of the liner to expand translates into further tangential stress.

Even if the cracks do open during heating, they are likely to be observed in a closed position when the chimney is cool. Such “hairline” cracks are fully consistent with the damage observed in thermal shock testing of hollow cylinders reported in the technical ceramics literature as well as from laboratory chimney fire tests.

Cracks do not always fully close upon cooling. Residual stresses within the liner, retained from the manufacturing process, can lead to displacement of the edges such that they do not match up perfectly. The displacement can be either axial or radial and does not necessarily indicate that some external force is pressing on the liner. Such displacement was observed when one of the chimneys tested by the National Bureau of Standards was disassembled after the chimney fire.⁴

If some material lodges in the crack while it is open, it also may not fully close. This can happen during the fire that caused the crack or during periods of expansion during subsequent heating, including normal use. As the crack is held open, more material may enter the gap, and the original crack can be progressively ratcheted wider and wider. Thus, as a chimney is used after a chimney fire, there is an increased probability that cracks will be found in an open position. Just as hairline cracks are consistent with damage from a chimney fire, so are open ones. *The width or lack of width of a liner crack does not, in itself, indicate anything about the nature or severity of the force that caused it.*

The behavior of clay flue lining under chimney fire conditions is consistent with the well-established principles of thermal shock on ceramic materials. The dynamics of actual chimney fires are immeasurably more complex than can be expressed in generalized principles. Chimney fires rarely result in uniform heating of the inner flue wall. Instead, turbulent flames and hot gases and uneven propagation of the fire through solid material on the surface will create complex and changing temperatures and heat flow through the material will be equally complex.

In real chimneys, the nature of the wall surrounding the flue will significantly influence the temperature gradient. In some chimneys, an air space (as specified by codes) is present between the liner and chimney wall. In others,

the chimney wall is in contact with the flue or mortar has been slushed in tightly behind the liner. Loose rubble fill next to the liner can cause point concentrations of stress which must be added to thermal stresses. The environment surrounding the chimney, the materials and thickness of the chimney wall, and the overall mass of the structure are all factors which influence the ability of the liner to warm up in response to a temperature change.

As discussed in Chapter 2, clay flue lining itself is not a uniform product. Different raw materials, methods of manufacture, thickness, size, and shape can all be expected to influence the ability of any given tile to withstand the effects of thermal shock. Even if further experimentation were done to more closely fix the time and temperature relationships needed for thermal shock failure, considerable variation could be expected for different brands and sources.

The mathematical models used for analyzing stress development will never be adequate to fully describe the actual stresses developed in a particular lining in a specific chimney during any given chimney fire. On the other hand, it is not really necessary to do so. It is empirically indisputable that clay flue lining does crack under chimney fire conditions. The observed nature of the cracking is consistent with the modes of failure predicted for ceramic materials of the composition and shape characteristics of flue lining. Certain additional phenomena, such as occasional spalling of the liner surface and a certain delay from the application of heat to the onset of failure, are consistent with both the behavior of chimney fires and the physics of temperature gradients. While the exact etiology of the cracks in any given flue may be unknowable, the association of chimney fire damage with thermal shock should be clearly established.

NOTES

1. W. D. Kingery, “Factors Affecting Thermal Stress Resistance of Ceramic Materials,” *Journal of the American Ceramic Society*, Vol.38, No. 1, 3-15, 1955.
2. *Introduction to Ceramics*, W. D. Kingery, John Wiley & Sons, New York, 1960.
3. Richard Peacock, *Intensity and Duration of Chimney Fires in Several Chimneys*, National Bureau of Standards, Center for Fire Research, NBSIR 83-2771, 1983.

4. Richard D. Peacock, Thermal Performance of Masonry Chimneys and Fireplaces, National Bureau of Standards, Center for Fire Research, NBSIR 87-3515, 1987.
5. Richard Stone, "Solving the Creosote Problem," (Wallace Murray Corporation), *Fire Journal*, January, 1980.
6. R. A. Hart & H. W. Clark, "A Study of Flue Lining," *Journal of the American Ceramic Society*, Volume 10, 795-803, 1927.
7. Paul E. Cox & H. Ford Muecke, "Progress Report on the Improvement of Clay Flue Liners," The Bulletin of the American Ceramic Society, Vol. 19, No. 1, 19-22, 1940.
8. Nolan Mitchell, "Fire Hazard Test with Masonry Chimneys," *NFPA Quarterly*, National Fire Protection Assn., October, 1949.
9. Jay Shelton, Shelton Energy Research, Santa Fe, NM. Unpublished, proprietary research involving chimney fires in five masonry chimneys with different construction characteristics.

Chapter 4:

Field Evaluation of Chimney Liner Damage

4.0 INTRODUCTION

Previous chapters have described chimney fires and their dramatic thermal effects and have established that damage to the flue liner is commonly discovered after a fire. The mechanism of such damage is thermal shock. Several fairly solid generalizations about the cause and peculiar characteristics of chimney fire damage have been drawn from this discussion.

Knowing that a force *can* cause damage is not the same as knowing that the force *did* cause damage to a particular chimney. Other forces can cause damage to flue lining and there are cases where on first examination such damage appears similar to chimney fire damage. It is also true that chimney fires do not *necessarily* cause damage to the flue although the likelihood may be great. There is a need, therefore, to bring general principles home to specific cases and to develop techniques for applying knowledge about chimney damage to the diagnosis of the distress in particular chimneys.

The purpose of this chapter is to establish a basis for evaluating and diagnosing the cause of observed damage in a chimney with reasonable confidence. Since this is a report on chimney fires, the primary focus will be on developing evidence of chimney fire damage. However, actual or potential damage from other sources can sometimes be confused with chimney fire damage, and one method of increasing the credibility of a diagnosis is to be able to eliminate or discount other unlikely explanations. The behavior and effects of other forces at work in a chimney will therefore also be examined.

The evaluation and diagnosis of damage to structures is often thought of as the province of engineers. Since the ability to relate fundamental principles of material properties and stress development to particular problems is of clear value, this is understandable. However, chimneys are unique structures which are not often studied, so familiarity with their construction, dynamics, and modes of failure is not as common as with other engineering subjects. The Chimney Safety Institute was fortunate to have had the advice of Mr. Floyd Herrick of Herrick-Saylor Engineering,

PC, Rochester NY, in the preparation of this material. Mr. Herrick has been involved in analysis of field damage to masonry chimneys and has used his experience to help formulate a clear understanding of the mechanisms and symptoms of a wide variety of modes of damage. In addition, Mr. Jerry G. Stockbridge, of Wiss, Janney, Elstner Associates, Inc. of Northbrook, IL has provided a valuable critique of the application of masonry engineering principles to the problem of chimneys. Much of the following analysis of thermal and moisture expansion is based on his comments.

The experience of chimney service professionals who work with both distressed and sound chimneys as a matter of course is also an irreplaceable resource for the evaluation of chimneys. This chapter is thus based on both principles of engineering and the wisdom born of experience.

4.1 GENERAL PRINCIPLES OF EVALUATION & DECISION MAKING

Information on the diagnosis of distress in residential buildings is severely limited and virtually nonexistent for particular structural components such as chimneys. This void in specific validated resource material means that every analysis must be done on a “custom” basis by applying known principles to the characteristics of the structure and its observed symptoms. This “customizing” often leads to misapplications of those known principles and high-sounding explanations which simply don’t make sense. The fundamentals of stress and strain seem so inaccessible to non-specialists that such flawed diagnoses are often left unchallenged.

One of the purposes of this chapter is to begin (although probably not end) the process of building a decision-making methodology about the causes of damage observed in masonry chimneys. It is probably premature to attempt to assemble a comprehensive troubleshooting chart like one finds at the back of appliance manuals, and real chimneys may never be completely amenable to such a simplified treatment. It is not unreasonable, however, to attempt to examine

most of the forces that are commonly brought to bear on chimneys and see how their effects translate into particular forms of damage.

Before such a technical assessment can begin, certain rules of investigation should be established. Foremost among them is that **any explanation for some observed problem should be traceable from cause to effect**, not the other way around. It is usually the effects which are obvious by the time problems with chimneys become evident, so it is tempting (and sometimes unavoidable) to try to discern the cause by studying the effect. Sometimes generalizations about the causes of certain damage patterns are offered without checking to see if the cause is likely or even possible in the particular situation.

Many of the damage patterns that show up in chimneys can look similar yet have diverse causes. At best, observation of damage might suggest a hypothesis – usually more than one. The honest investigator will go back to these possible explanations and examine each for plausibility. First, *it must be possible for the cause to have occurred* not just in general but under the conditions existing in the particular case. Secondly, *there must be a path to connect the cause to the effect.* For instance, settlement of chimney foundations is a reasonably common occurrence, but to qualify as an explanation for cracks in a flue liner at the top of a chimney there must be some means for translating movement at ground level into fracture stress at the terminus. The mere presence of a potential or even actual force does not necessarily implicate it as the cause of damage.

Reasoning from cause to effect also helps in recognizing variations in effects. In a perfectly orderly world, every force or event would have the same predictable consequences time after time from house to house. The fact that known forces do have some fairly consistent effects makes it possible to undertake the diagnostic process, but variations in chimney design and construction technique, materials, and exposure conditions make it possible (even likely) that the ultimate effects will be manifested differently in different cases. By understanding the nature of the cause, what force it exerts in what direction, and how it affects different materials and shapes, one can appreciate its application to particular circumstances.

Consideration of the plausibility of hypothetical explanations will usually eliminate several unlikely candidates immediately and will simplify analysis of the remaining ones. It is not unusual to examine two possible explanations and find that either could have happened and that there is a plausible route from cause to observed effect for each. A basic familiarity with the mechanisms which may be at work and some appreciation of the properties of the materials involved helps with evaluation of the context of the damage. In many cases something must also be true in order for a particular explanation to be valid. By forcing him/herself to consider all the implications of a potential cause, the investigator can know where to look for confirming evidence or know how to recognize inconsistent phenomena.

It is rarely possible to “prove” that a particular force caused a particular effect. The only satisfactory proof, in the strict sense, is direct observation: actually witnessing the force at work and seeing the damage develop as a result. Just as watching concrete dry is not a popular pastime, watching a chimney crack is not usually a productive diagnostic technique. If time is available, it may be possible to test a hypothesis by periodically recording the progress of a crack or waiting for related effects to show up. Usually, however, a credible explanation is needed as soon as possible, and the investigator must rely on the available evidence and practical reasoning to derive a workable diagnosis.

A decision about the best explanation must usually be based on a preponderance of evidence rather than on some elusive “magic bullet” that explains everything. One of the most common errors in field evaluation of chimneys is to seize upon some particular piece of evidence that unequivocally demonstrates the inevitability of the investigator’s favorite explanation. The investigation often stops once this fortuitous observation is made and incompatible facts are dismissed or never considered. *The most credible diagnosis is inclusive; it explains the relationship between cause and effect and accounts for, or at least is not inconsistent with, the rest of the available evidence.*

Most people are familiar with the story of the group of blind men who, when given the task of describing an elephant, each based his conclusion on his touching of one particular part. The one

who felt the trunk described the elephant as like a snake; the one who grabbed a leg reported a tree-like structure; the one who was hit by the tail knew the elephant by its whip-like behavior. Despite their apparent simplicity, chimneys are complex structures, and many observations can be made about their condition, usage, relationship to their environment, exposure to stresses, and response to external forces. Many of these observations will be irrelevant to the ultimate diagnosis, and some observations could be used to support competing explanations. *The best explanation is the one that is most consistent with the overall body of evidence, not just selected bits and pieces.* To be accurate and useful, the assessment of chimney damage must make sense regarding the entire structure and the entire sequence of events that are presumed to have led to the damage.

It follows that a chimney inspection for purposes of diagnosing damage should be as complete as possible. Investigators are inevitably drawn to the damage itself which is usually well-documented and analyzed. *The mark of a good inspection, however, is that it considers the parts of a chimney and the history of its use that may appear to have no bearing on the damage.* This extra effort may not turn up anything that affects the proposed diagnosis either way. On the other hand, it may show factors which don't fit or which suggest a better explanation.

Considering the body of evidence highlights another important principle: *a single explanation is not necessary for all the damage present in a chimney.* There is no reason to suppose that only one force capable of causing damage has been brought to bear on a chimney over the course of its life. It is therefore likely that evidence can be developed to show that more than one cause of damage has been active. The fallacy is to claim that, because one peculiar mode of damage is present, all observed damage must be lumped under this explanation. A chimney inspection may have been triggered by some unusual event (such as a chimney fire) which is known to carry the potential for damage. Too often, the resulting report swings dogmatically in one direction or the other – either the damage was pre-existing and had no relationship with the event or the event must have been responsible for all the distress. Many chimneys display the effects of multiple forces. A responsible report will attempt to identify each of these forces and distinguish their

effects.

It may, in fact, not be possible to fully separate specific items of damage into distinct categories, each with its own explanation. Particularly when damage patterns for different causes are similar, analysis of individual cracks or other irregularities may not point overwhelmingly to one cause or the other. Unless the possible causes of the problem are completely incompatible, *the most responsible diagnosis includes all plausible explanations.* It may be advisable to take action to correct all problems. Concentrating on one or the other may deprive the property owners of the remedies needed to ensure the integrity of their venting system.

Just when the evaluation of chimney damage appears to be becoming unworkably complex, we should be reminded of a basic rule of scientific investigation: *the simplest explanation is usually the best.* Although chimneys consist of a number of components which can be combined in innumerable ways and subject to a variety of conditions, the forces which can affect them are fairly easy to understand. Measuring and quantifying the degree of various strains and stresses may be a job for a specialist, but their qualitative effects are accessible to anyone with patience and integrity.

Sometimes investigators go to great lengths to establish the possibility that subtle and mysterious forces may have caused the damage while ignoring the obvious: the major documentable sources which are known to cause stress orders of greater magnitude. The explanation offered invariably sounds contrived. This is not to dispute the fact that sometimes subtle forces do cause damage, but when *evidence of simple and direct causation is available, complex explanations will usually miss the mark.* *The ultimate test of a diagnosis of chimney damage is its reasonableness.*

4.2 DEVELOPING EVIDENCE OF CHIMNEY FIRE DAMAGE

Because this is a report on chimney fires, one of the best ways to illustrate the diagnostic process is through an analysis of possible chimney fire damage. The evidence developed can then be compared with the characteristics of other sources of damage and the effects of chimney fires more clearly distinguished from them.

As discussed in both Chapters 2 & 3, the damage patterns associated with chimney fires are so consistent and compelling that it is tempting to argue backward from effect to cause: if such patterns are found, they must have been caused by a chimney fire. In many cases this hasty generalization may ultimately be borne out, but responsible diagnostic technique demands that the rules be followed even when they seem superfluous.

The analysis of chimney fire damage, then, should begin with establishing the plausibility of the force and its connection with the observed damage. *An inventory of the characteristics of the chimney and its conditions of use should not be neglected either.* The result should be a body of evidence which is most consistent with a chimney fire as an explanation for the damage and not so consistent with another plausible explanation. The analysis of chimney fire damage has one big advantage: chimney fires and the resulting thermal shock are such manifestly un-subtle forces that, when the above criteria are satisfied, they usually offer the simplest and most direct explanation for flue liner damage. *If the occurrence of a fire and the existence of consistent damage patterns can be established, and clear evidence of some other cause is not available, the conclusion that the fire caused the damage is almost inescapable.*

Most of the signs of a chimney fire and characteristics of the damage they cause have been fully discussed in Chapter 2. The technical mechanisms of thermal shock have been discussed in Chapter 3. Both discussions are summarized here in the context of developing a body of evidence to link the occurrence of a fire with observed damage.

4.2.1 OCCURRENCE OF FIRE

As with any possible cause of damage, developing a credible case for chimney fire damage includes some reason to believe that the force has actually been brought to bear on the chimney. Unlike most of the other sources of damage (which take place over a period of time without drama), chimney fires are distinct and usually isolated events. Clearly, this should make identification of such a potential cause of damage much simpler than for the more subtle time-dependent perils to which a chimney might be exposed. Indeed, many inspections for possible chimney fire damage are prompted by someone's experience of

the obvious phenomena associated with a fire. In these cases, establishing the plausibility of the cause of damage should be fairly straightforward.

Just as it is not necessary to actually see a foundation move in order to analyze settlement damage, there is no particular reason that a chimney fire must be witnessed to be a credible cause of damage. When direct evidence from witnesses is available, it should be used, but the physical evidence associated with chimney fires can be just as compelling and helps reinforce the accounts of witnesses. *Documentation of a possible chimney fire includes collection of both direct and physical evidence.*

Direct Evidence

The phenomena associated with "classic" chimney fires have been fully described in Chapter 2: a noisy inrush of air, vibration of venting system components, possible backpuffing of smoke, crackling or cracking sounds, heavy black smoke or flames issuing from the chimney top, etc. Except for backpuffing, none of these is associated with normal operation of wood-burning appliances, and most are so unmistakably abnormal that their occurrence can be taken as *prima facie* evidence of chimney fire. There is no guarantee that all possible signs of a fire will occur, but the experience of even one suggests that something out of the ordinary has transpired.

Because there remains a pervasive misapprehension that chimney fires are benign events and because the arrival of fire engines at one's house can be distinctly embarrassing, most homeowners do not call the fire department even when they know a fire is occurring. There is no logical reason to suppose that a fire does not exist unless it is witnessed by firefighters, so their presence is not essential to documenting the occurrence of a chimney fire. Still, if the fire department was called, a report which is usually a matter of public record will have been made. Although many reports are sketchy, they will often shed light on the status of the fire upon arrival, the extent to which it involved the flue, and the means used for extinguishment.

As discussed in Chapter 2, not all chimney fires adhere to the "classic" model, and not all occur in the presence of a witness. It is not unusual for a homeowner to be unaware of a fire while it was happening. While that lack of a clear experience of a fire makes documentation more difficult, it

does not automatically rule out the occurrence of a fire. Slow chimney fires do not necessarily develop the outward signs of a full-blown fire, but even glowing combustion on the surface of a flue can develop temperature gradients far in excess of those obtained during normal operation. Although most fires start as a result of some action on the part of the operator, they have been known to occur in the middle of the night or while no one was home.

In many such cases, the homeowner may have noticed some abnormal behavior in their system, but may not have attached any particular significance to it at the time. Relatively quiet tinkling or crackling sounds in the stovepipe or chimney can be indicative of smoldering combustion of creosote, but may be dismissed or ignored by an observer. Similarly, residents may come home to find a load of wood unexpectedly consumed or their house very hot, indicating that the fire may have gotten out of control in their absence. Sometimes a recollection of such experiences can be drawn out under careful non-leading questioning. Since this tenuous evidence is not conclusive, it is best when backed up by physical evidence.

An assessment of the direct evidence of a chimney fire should also include the actions taken during and after the fire. Physical evidence can be removed or masked by actions taken in response to the fire and by renewed use of the chimney. If the chimney is cleaned before being inspected, telltale creosote residue may have been removed. Use of the chimney may build up fresh creosote, and smoke may stain newly exposed crack surfaces. The evaluation of physical evidence will have to account for any such complicating factors.

Physical Evidence

Chimney fires nearly always leave evidence behind. Many investigators are more familiar with the gathering of evidence of structure fires, and much of the evidence may be located in the relatively inaccessible shaft of the chimney flue, so this evidence is often not recognized or appreciated. Not all chimney fires behave the same way, so there is no single condition that is always found after a chimney fire with the near exception of pyrolyzed creosote. A thorough inventory of the range of possible signs in combination with direct evidence will usually clarify whether a fire occurred or not. A full

description of the phenomena summarized here, together with their causes, can be found in Chapter 2.

- *Pyrolyzed Creosote:* The change in the character of creosote is the single most distinguishing sign of a chimney fire. Tar glaze creosote pyrolyzed slowly by normal operation may be crusty and granular but still relatively dense. Creosote pyrolyzed rapidly by a fire will be extremely light and expanded in volume. It will appear like frozen foam or in tissue paper-thin leaves like French pastry. It will be very fragile and may break off from incidental contact.
- *Well-pyrolyzed creosote may be noncombustible:* It is highly unlikely for creosote to be fully pyrolyzed to ash during normal operation, particularly in the upper parts of a chimney. A chimney fire of sufficient intensity and duration may consume all the fuel components of creosote, and the residue may no more than temporarily glow when subjected to direct flame. This is not always true, however, so the form of creosote described above is a better test than its noncombustibility.
- *Creosote is likely to be present throughout the flue:* If the fire was free-burning or not extinguished early, expanded pyrolyzed deposits are usually found from top to bottom. If the fire was limited or extinguished, the expanded deposits may be concentrated at the bottom, with more conventional deposits higher up. Upper deposits may be pyrolyzed but may hide underlying unaffected glaze. These observations can often be correlated with the accounts of witnesses.
- *Some creosote will be found at the bottom, or expelled from the top, of the chimney:* Most deposits will continue to adhere to the flue walls even after pyrolysis, but a significant portion has usually broken off during the fire, and a substantial pile of the characteristic lightweight material will be found in the cleanout or smoke chamber or on top of a fireplace insert. Similarly, some of the material may be carried up the flue by draft and found in the area around the chimney
- *Anomalous patterns may be found in the flue:* During normal operation, creosote is deposited

more or less uniformly, and heat is applied uniformly by flue gases. The character of creosote may change gradually from top to bottom, but abrupt non-uniformity is rare. Chimney fires are disorganized events, however, and the fire may affect deposits in close proximity differently. Particularly during slow fires, deposits on one wall may be pyrolyzed and adjacent deposits may be unaffected. The burn patterns may be patchy because the fire changed in intensity as it progressed up the flue

- *Isolated scorched or scoured areas on the flue may be observed:* Areas of very intense combustion can develop at particular locations, often associated with an air leak through a liner joint or crack. In these areas the creosote may be literally incinerated and even soot stains may be burned from the flue, leaving a clean flue surface. Spalling of the liner surface is sometimes found at these locations. This is a clear indication of a fire since accumulating creosote does not selectively avoid particular areas.
- *Occasionally, the flue may be cleaned by the fire:* When temperature or drafts during the chimney fire are very high or the deposits are very thin, creosote can be mostly consumed or drafted out of the chimney. Usually expelled debris will be found all over the roof or yard unless they are carried away by wind or rain, and some loose debris will fall to the bottom of the chimney. It is sometimes suggested that the flue must be cleaned in order to indicate a legitimate fire, but the conditions for doing this are so exacting that such cases are a distinct minority. It is far more normal to find most of the residue adhered to the flue.
- *Tar glaze may have melted away from the fire:* When heated, tar glaze becomes a viscous semi-liquid. Most of it will be pyrolyzed in place by the fire, but some may flow away from the combustion zone and be found in the form of a glacial mass or frozen drip. This is most common near the bottom of a fireplace smoke chamber, around the bottom of a fireplace insert, in the cleanout area below the thimble entrance of a stovepipe, or around a chimney cap.
- *Burned creosote may be found below the source of heat:* Instead of melting before

catching fire, the creosote will sometimes ooze or drip as a flaming mass like lava from a volcano. If pyrolyzed creosote is found on the wall of an area not normally exposed to heat or smoke (such as the cleanout area), that is a sure indication that a fire has occurred.

- *The fire may have affected other objects:* Black stove pipe may show a patchy light gray discoloration from oxidation of the paint. Antennas attached to the chimney or nearby trees may show heat damage. Depending on the severity of the fire, metal chimney caps will show moderate to major damage. In extreme cases, aluminum caps will melt, and steel caps will warp. Shiny stainless steel caps will show dichotic discoloration at fairly low temperatures, but red or salmon shades, or a clear area surrounded by blue, purple, or brown rings, indicates exposure to temperatures over 1000°F.¹ Damage need not be extreme to be indicative of a fire. Normal operating temperatures at the top of a chimney are not usually high enough to damage the paint used on quality caps. Even a limited area of discoloration may be consistent with a slow fire or one that was limited or partially extinguished early. However, some caps with less durable paint may show deterioration immediately above the flue after normal use. Unless damage to paint is clearly new or clearly caused by fire, it is best to not take damaged paint, by itself, as evidence of a chimney fire.

Most of the above signs of fire are best detected shortly after the occurrence of the fire. It can become increasingly difficult to assess the likelihood of fire as time passes. If the homeowner was not aware of the occurrence or neglected to have the chimney inspected, the evidence may be gone or masked by the effects of subsequent usage.

Expanded pyrolyzed creosote is fairly persistent when sheltered in the chimney flue. It is not uncommon for this telltale sign to be encountered the next time the chimney is routinely cleaned. This discovery will often trigger a follow up inspection for further fire evidence and the possibility of damage. Although prompt inspection is certainly preferable, evidence of fire is still evidence of fire even after significant time has passed.

Unless the creosote has swelled to restrict the flow of smoke, the subsequent operating behavior of the attached appliance may not be affected by the occurrence of the fire. New creosote may build up on top of the burned material, and the presence of fresh un-pyrolized material may mislead some investigators. It should not be too difficult to understand, on reflection, how this is not inconsistent with the possibility of fire.

4.2.2 CHARACTERISTIC DAMAGE FROM CHIMNEY FIRES

As in the diagnosis of any source of chimney damage, the type of damage itself must be consistent with such causation, and there must be some plausible path from the force to the observed effect. If the occurrence of a fire has been verified or strongly suggested, the route of damage is rather obvious: direct application of excessive heat to the affected component. The effect of rapid or extreme temperature rise on ceramic materials such as brick or clay tile has been well-documented. Chapter 3 outlines the mechanisms of damage and most likely patterns resulting from thermal shock. The primary task, then, is confirming that the nature of the damage and its context is consistent with the potential effects of a chimney fire.



Figure 4-1. The interior of a clay flue tile-lined chimney illustrates the impact of a chimney fire – multiple cracks in tile liner sections and a missing segment of tile which fell down into the smoke chamber/damper area.

One of the better indications that damage was caused by a fire is evidence that it is fresh or of relatively recent origin. It is particularly important that the gathering of direct evidence from the property owner include any significant history of chimney inspection or repair. If a previous

inspection record (such as by a chimney sweep the previous year) indicates that damage was not present, that is a strong indication that currently observed damage developed quickly. Although it is conceivable that some other more subtle force could have caused damage coincidental with a chimney fire, such a fortuitous explanation demands strong documentation.

Subsequent use of an appliance or events during the fire may mask the signs of freshness, so they will not always be observable. Evidence of recent origin is a positive indication of fire damage. The lack of such evidence is neutral unless there is positive indication that the damage predated the fire. The application of these principles will be discussed in the context of the specific forms of damage.

Damage To The Flue Liner

Damage to the liner can often be observed near the top or other openings to the flue and thus be directly documented. A full examination should, however, include the entire flue. *The inner reaches of a flue are relatively inaccessible, and it should not be expected that the distant oblique view from the top or bottom is adequate to fully document damage even with strong light. When there is any question of the existence of damage, special video inspection equipment should be employed.* A summary of the most common characteristics of liner damage follows:

- *Longitudinal Fracture:* As has been thoroughly discussed in Chapters 2 and 3, cracks parallel to the liner axis are a strongly characteristic and virtually necessary form of chimney fire damage. They may extend from end to end of each section or from only one end. They may be located in a flat face of a rectangular liner or in or near a corner. They may be open or closed back down to a hairline. *If they are observed on the inside face, they almost certainly penetrate the liner wall since cracking is initiated on the outer surface.*
- *Extent of Damage:* Cracking need not extend the entire length of the flue, but it often does. Fires that had been limited or extinguished may have caused damage only to areas actually reached by the fire. Damage is usually more severe in liner sections closer to the bottom of the chimney since that is where chimney fires start and temperatures rise most suddenly. In

some cases, damage can be more severe toward the top or other level because of variations in fire behavior or chimney conditions at different locations. Individual liner sections may be cracked on different faces, depending on stress development and individual weakness. This is distinct from other forces which may exert force in the same direction on each section.

- *Transverse Fracture:* Cracks running sideways or around the liner can develop during a chimney fire, but they must nearly always be secondary to an initial longitudinal crack. A transverse crack by itself in one section does not necessarily discount fire damage in other sections, but it does strongly suggest that some other force is also causing damage to the chimney. Transverse cracks may not be found at all, but if they are present, they are more likely located in the more heavily damaged liner sections, generally toward the bottom of the chimney. Transverse fractures appear to be more likely when the flue liners are tightly encased in mortar.
- *Fully Broken Lines:* If the fire and resulting damage have been severe, cracks may run together, creating separate shards and pieces of liner. These may remain in place but be loose and easily dislodged. In some cases, the strain released during fracture is sufficient to “blow out” shards which may fall to the bottom or be wedged in the flue.
- *Width of Cracks:* Liner cracks resulting from a chimney fire can be found either open or closed. Unless restrained by tight surrounding masonry, cracks are likely to open up during heating because of continued differential circumferential expansion. Upon cooling, however, they are likely to close back up to a hairline, which is how they are often observed. There is nothing about a hairline crack that is uncharacteristic of a chimney fire. The width of liner cracks usually tell little about their cause. However, while cracks are open, they may become clogged with chips of liner or other debris which prevent full closing. Progressive ratcheting of cracks becomes more likely as the chimney is alternately heated and cooled with subsequent use but can happen during the initial incident. Because of latent stresses in the liner or the effect of ratcheting, the edges of cracks may be displaced radially or axially relative to each other.
- *Spalling of Liner Surface:* In severe fires or at areas of locally intense combustion, shear stress between the extremely hot surface and adjacent cooler material may cause flat plates or leaves of liner to flake off. The liner surface will be distinctly cratered with one large or several small areas of damage. The broken pieces can usually be found at the bottom of the flue.
- *Damage to Joints Between Liner Sections:* The joints between sections are in some senses the most vulnerable parts of a flue, and construction techniques and materials choice are typically poor or inappropriate. Standard masonry mortar may spall from thermal shock, and sodium silicate-based cements may soften at chimney fire temperatures,² but they are unlikely to flow. Care must be used in interpreting joint damage since construction and materials defects commonly lead to pre-existing erosion even under benign conditions.
 - *Evaluation of Recent Occurrence:* If cracks are inspected shortly after the fire, but before renewed use of the appliance, they may show unequivocal evidence of being new. The exposed interior surfaces of cracks, if visible, may be clean, showing the original liner color unstained by smoke or creosote. Creosote melted during the fire may flow into or through cracks as they are created or may obscure their inner surface. Cleaning of the flue in preparation for inspection, particularly with liquid chemicals, may also stain cracks. On the other hand, if the interior of the crack shows uniform smoke stain, and the appliance has not been used since the fire, that is *probably* a good indication that the crack predates the fire.

The edges of new cracks may be sharp and clearly defined. Older cracks may have been eroded and show a softened and less distinct edge.

Broken shards of liner or spalled material may be found at the bottom of the chimney. Unless the material is somehow exposed to smoke flow, it should be clean except for the original interior flue surface. *However*, it is also possible that the material was cracked or broken by a previous chimney fire or other force and only fell out during the current incident. In these cases, smoke or creosote-stained shards say nothing about damage from the recent fire. If they are found at the bottom, buried in *non-chimney* fire creosote or

ash, they may be assumed to have fallen out before the fire occurred.

Other Damage To Chimney

Damage to the liner is a far more likely result of a chimney fire, but sometimes additional damage is done to the chimney wall. It has sometimes been suggested that unless the chimney wall cracks, thermal shock could not have been significant enough to cause liner fracture. This assumes that wall cracking is a precondition of liner damage. There is no empirical basis for this assumption, and the analysis of chimney wall failure in Chapter 2 should make it clear that quite the opposite is more likely.

The chimney wall is insulated from the most intense temperature rise by the flue liner. It is therefore unlikely that a destructive temperature gradient will be developed through the chimney wall during most chimney fires. However, fires of sufficiently long duration may cause the exterior surface of the liner to heat up to the point where substantial heat is transferred to the wall. Under these conditions, it is possible for thermal shock cracking to occur. Although the amount of expansion is relatively small, flue liners will expand radially during a fire. *If the space between the liner and wall has been tightly filled with mortar, the expanding liner could conceivably exert enough pressure to crack the wall under tension.*

If chimney wall cracking from thermal shock or radial liner expansion does develop, it will most likely consist of one or more vertical fractures which cut through masonry units without regard to mortar joints. However, because of the lesser importance of hoop stress, this pattern is less predictable than for flue liners. Because the interface between brick and mortar is a natural plane of weakness, cracks may have some tendency to follow joints. The crack may even follow bed joints for a short distance but full transverse joint cracks are more likely because of the lifting of the chimney, discussed below. Steam and occasionally creosote may leak from wall cracks during a fire, and stains left behind may be evident.

Cracking can also develop as a result of axial thermal expansion of the liner. If the top of the chimney is anchored to the liner, it will tend to be lifted as the liner expands. The usual result is a full broken bed joint encircling the chimney. If

the top of the chimney settles fully back to its original position after cooling, such cracks can be extremely difficult to detect even when their location was noted during the fire. However, if something lodges in the crack while it is open, it may remain visible. Incidentally, one consequence of this incomplete return is that a gap must develop at a liner joint or a broken liner be pulled apart.

The chimney or fireplace system may display other miscellaneous damage. Among the more common are thermal shock fractures to face bricks above a fireplace lintel and warping of damper frames or valve plates. Metal fireplaces forms, particularly those with an integral smoke chamber, may also be warped. Damage to stovepipe and chimney caps have been discussed above.

Damage To The Building

Despite the extraordinary temperatures produced, more than 90 percent of chimney fires involving masonry chimneys remain contained to the chimney – the building is not damaged.³ This is in large part due to the substantial thermal mass of masonry chimneys which can absorb a large amount of heat with relatively low temperature rise. Unfortunately, some fires – particularly those of long duration or which take place in a previously damaged chimney – do spread to the house.

Damage to the house can be either from fire, smoke, or both – plus water and other damage from extinguishment and overhaul. Most commonly, smoke damage results from backpuffing or smoke spillage from the appliance or other chimney openings. Roofing material is occasionally ignited by burning brands expelled from the chimney.

The most serious building damage initiated by chimney fires involves ignition of structural members adjacent to the chimney. Despite their thermal mass, masonry chimneys can get quite hot if the fire is of sufficient duration. If combustible material were kept clear of the chimney, as called for by codes, ignition would still be unlikely. *Most masonry chimneys are built without regard to code clearances, and ignition of previously pyrolyzed wood has been documented both in the field and the laboratory.*⁴ Because of the importance of chimney fire duration, there is some evidence that slow chimney fires may carry more

risk in this respect. Such fires are doubly dangerous in that they involve ignition, sometimes after the fire department has returned to the station from a flue fire. Statistically, delayed detection and concealed area of origin lead to both greater property damage and risk of personal injury.

In fires involving loss to the building, most damage assessment is naturally focused on the house. Accounting for damage to the chimney itself should not be neglected, however, if for no other reason that to prevent a damaged chimney from being returned to service.

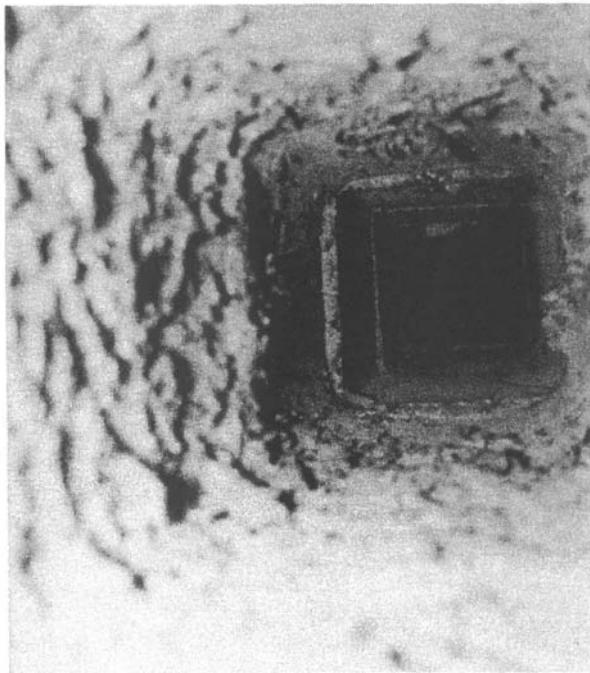

Figure 4-2. Looking down into a chimney lined with clay flue tiles after a chimney fire. Note that the lower tiles have been burned absolutely clean while the higher tiles show significant amounts of expanded creosote ash. Close inspection reveals cracks in the liner, but no liners are displaced.

4.3 EVALUATION OF OTHER POSSIBLE CAUSES OF CHIMNEY DAMAGE

If there is evidence that a chimney fire has occurred, and there is damage consistent with that caused by chimney fires, the simplest and most direct explanation for the damage is the significant thermal stress developed by the fire. However, other forces can cause damage which may appear similar to that caused by fires. Before a final conclusion is reached about chimney fire damage, the possibility of an alternative explanation should be explored. If evidence can be found that another force is at work, and its connection with the damage is plausible, it may be

reasonable to attribute at least some of the damage to that cause. However, it is not necessarily true that all of the damage is due to another cause. It may be possible that both sources have contributed to the overall picture.

Following is a review (admittedly less detailed than offered for chimney fires) of a number of common causes of damage to masonry chimneys. These have been compiled by applying modes of damage common to masonry buildings and walls to the particular geometry, materials, and usage conditions of chimneys. These theoretical scenarios have been further refined by observations from the examination

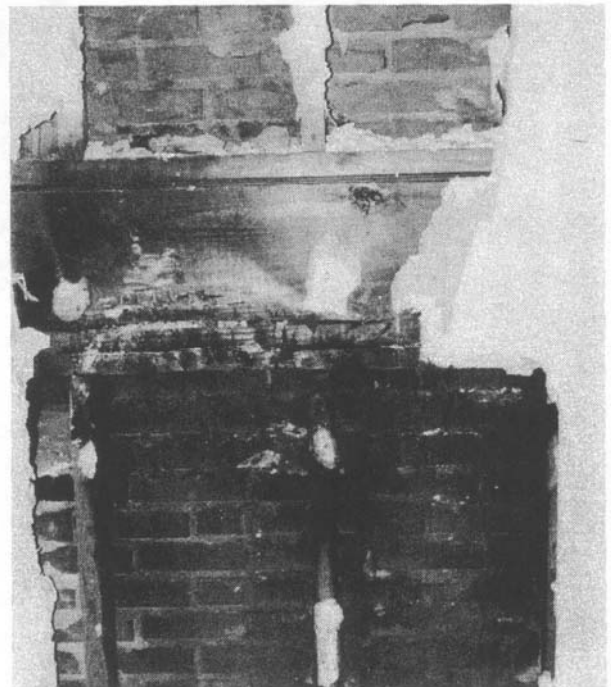

Figure 4-3. The exterior of the flue area of the chimney pictured in Figure 4-2. The charred header and framing in contact with the chimney and concealed by drywall covering were ignited by the heat generated by the chimney fire.

of a large number of actually damaged chimneys. For each possible cause, the nature of the force and how it develops is described. Its possible effects on the overall chimney are discussed, as are the ways that failure stress could be imposed on the liner or the chimney wall. The damage patterns most likely to be exhibited are described, as is any correlative evidence that should or could also be found to reinforce the diagnosis.

It should be noted that many of these causes of damage depend on or are aggravated by filling of the annular space between the liner and chimney wall with mortar or any other intimate contact of the liner with surrounding masonry. Most codes

call for an air space to be maintained between the liner and chimney wall, as discussed in Chapter 1. Among the purposes of this requirement is the permitting of the chimney structure and liner to function independently, allowing for differential movements and expansion. When this construction feature is executed properly, forces which may damage the chimney wall are less likely to be transferred to the liner, and vice versa. When the liner and chimney wall are locked together intimately, several of the damage patterns discussed below are more likely to develop. *An analysis of the plausibility of these mechanisms should include information on the status of this detail.*

4.3.1 DAMAGE FROM THERMAL CAUSES

In addition to chimney fires, several other modes of damage related to thermally induced stresses can be identified.

Non-Creosote Fire Thermal Shock

The exact conditions necessary for the initiation of thermal shock failure in clay flue lining is not known. A particular index of severity probably cannot be fixed, if for no other reason than the inherent variability of flue lining products. Most evidence suggests that a very rapid increase in inner surface temperature sufficient to cause a temperature gradient ranging from at least 500 to 600°F is necessary for predictable failure. A chimney fire is the surest way to achieve these conditions. If one is known to have occurred, that fact clearly overrides any suspicion about lesser conditions.

In the absence of a chimney fire, it is conceivable that thermal shock could be developed during other operating modes. Normal, routine operation can essentially be eliminated as a source of shock. However, there are two possible scenarios:

- *A Non-Creosote Chimney Fire:* As discussed briefly in Chapter 2, gases given off from incomplete wood combustion can ignite and burn in the chimney flue. This is most likely where an independent source of air is available. Flaming can last for a substantial period and can be located or move around anywhere in the chimney. Since this involves combustion in the flue, this is quite literally a chimney fire, and it can produce the same thermal shock effects as combustion of creosote.

- *Sudden and Significant Overfiring:* Flue gas temperatures at the appliance outlet of 1000 to 1400°F, while rare, can be developed by overfiring. Depending on the type and length of connector, the temperature at the chimney entrance will be lower and will further decrease higher up the flue. It may be possible that the inner liner temperature could rise quickly enough to initiate shock. However, several laboratory tests involving overfiring in this temperature range did not result in damage to the liner, so this possibility may be speculative

Neither of these events leaves distinctive physical evidence, so it may be very difficult to develop plausible evidence of occurrence. The recollection of a direct witness may be the only available indication.

If either of these events should occur, any resulting damage will follow the characteristic pattern of thermal shock, with predominantly longitudinal fractures. For the overfiring scenario, damage must almost certainly be concentrated toward the bottom of the chimney. It is unlikely that shock conditions could “skip” the bottom in favor of the top.

Lightning

Lightning technically involves a complex of forces in addition to heat, but for convenience it is discussed here. The cause of such damage is almost always obvious because a lightning strike is unmistakable to witnesses and because the damage is so massive. The top of the chimney is likely to be utterly destroyed, with the liner shattered and bricks dislodged. The usual location of a strike is the top, but damage can occasionally be found deeper in the flue. Lightning damage is not usually a diagnostic problem, and it need not be discussed further here.

Differential Thermal Expansion

Seaquist⁵ has accurately described the approach often taken to cracks in masonry structures, and the observation is just as applicable to chimneys:

“In the evaluation of the cause of any specific crack, thermal and moisture movements are given as an explanation almost by default. When all other explanations fail, the movements induced by thermal and moisture changes are blamed. In many respects this is not an altogether unreasonable way to figure out the cause of

distress. Somewhat like Sherlock Holmes' synthesis process of excluding the possible and arriving at the improbable, the diagnosis of cracking excludes the obvious, and the more subtle, less understood thermal- and moisture-movement phenomenon becomes the explanation."

Indeed, where the evidence of a simple and direct cause of chimney liner damage is not satisfactory, differential thermal expansion may offer a credible explanation. Chimneys are exposed to heat, and they consist of a combination of materials, so the opportunity for discontinuous expansion is clearly present. Problems develop, however, when investigators run too easily to this well. Too often, a vague undocumented reference to differential expansion serves as a cover for poor investigative work and a failure to properly consider the evidence of clear and direct causation.

Sequist emphasizes that for this explanation to be credible there must be *differential* movement between components. The mere *presence* of heat does not imply non-uniformity. We would add that the mere presence of a differential also does not imply that different components have been placed under stress or that failure stress has been developed. Invoking differential expansion as an explanation for cracking carries the burden of showing how, if expansion does occur, two components have been brought together in such a way as to induce failure.

Clay tiles and brick products have very similar coefficients of thermal expansion,⁶ so flue lining and brick heated to the same temperature will expand to essentially the same degree, and little stress would be expected. Concrete block has an even greater coefficient of expansion. Under uniform heating, when a liner is enclosed by a ring of block, the block wall would actually be expected to move away from the tile. However, a flue liner will clearly get hotter than the surrounding masonry except when the chimney is not operating at all. As a result, the liner can be expected to expand relative to the chimney wall which encloses it. The development of any stress, however, depends on the precise relationship of the wall and liner.

The liner will expand in all directions, which in a cylinder means radially, axially, and circumferentially. Radial and circumferential

expansion will translate into a larger diameter for the cylinder. A little multiplication will give some perspective on the degree of expansion which can result. If an eight-inch (ID) diameter round liner of standard thickness with a coefficient of expansion of 3.3×10^{-6} per degree F were uniformly raised in temperature by 1000°F, the diameter would increase by a total of about .03 inch, or .7 mm. For a 12 by 12 nominal rectangular liner under the same conditions, the increase in the width of each side would be about .0429 inches, or one millimeter. For normal operating temperature rises, the increase would be less and in proportion to the above. For example, a 500 degree rise would be half the figures indicated.

The absolute amount of differential expansion involved is slight. If the liner has even a tiny amount of "room to grow," no stress would be expected to develop. In a chimney with a code-specified air space in the annulus between the liner and chimney wall, this is very nearly the situation. However, if the liner is tightly encased with inflexible material (such as a backfill of mortar) or the air space is not continuous, the potential for a problem exists. The expansion of the liner may be restrained by the opposing wall and stress will develop. However, the liner will be under compression, pushing against the outer wall which will be under tension. Masonry material are much stronger under compression, than under tension, so the chimney wall is probably more likely to fail than the flue lining. The resulting crack will most likely be similar to a thermal shock crack – vertically oriented and cutting through masonry units but with some tendency to follow mortar joints.

Despite the above, liner failure is still conceivable but under rather specialized circumstances. If the material surrounding the liner is not uniform, a point of stress concentration can be developed on the liner wall. For instance, if masonry rubble has been placed around the liner, a sharp point of brick may press against the side of the liner. If the rubble is locked in so tight that even a tiny increase in diameter cannot be accommodated, failure stress at the point of contact could be generated. The pattern of the resulting crack is difficult to predict. It may radiate in one or several directions from the point of contact like a spider web. If a single crack develops, it is probably at least as likely to be transverse as longitudinal.

Under some circumstances, axial expansion of the liner may be of more concern than the increase in diameter. Thermal expansion is directly proportional to the length of the material involved, so the total expansion of a full liner or even a single section will be much greater than the minuscule numbers quoted for the diameter. If a 25-foot liner were uniformly raised in temperature by 1000°F (which is rather unlikely), the overall length would increase by about one-inch. Shorter lengths or lower temperature rises will result in proportionally less expansion.

Again, a condition must be demonstrated where expansion of the liner is restrained to the point of failure stress. If the liner is tightly attached to the top of a chimney or crown, as it often is, the expansion may lift the top portion of the chimney (or more rarely, a large part of the chimney) above lower portions. This phenomenon occurs during chimney fires as well, and has been discussed more fully in that context. The degree of expansion during normal operating temperatures will be less, as will the degree of lifting, but otherwise the behavior should be the same. Even though the weight of part of the chimney has been transferred to the vertical column of chimney liners, the compressive strength of flue liner material (on the order of 8,000 psi), would not normally be exceeded, it should be noted.

At least two circumstances can be identified where restrained axial expansion can translate into *shear stress* in the liner and failure can be induced. Ideally, the mortar or cement between the joints of flue liners will form a uniform bed for each section, evenly distributing any stress around the entire cross-section. Mortar joints often become eroded, however, or may not have been properly filled during construction. As a result, the joint material may not form a uniform cushion; and stress can bear unevenly on the end of the tile. Under the right combination of force and uneven support, the liner could fail from the resulting shear stress.

The second possibility involves restraint of axial expansion by backfill material tightly surrounding the exterior of the liner. If the liners are tightly encased in mortar, the bond between the two will resist the upward movement of the expanding tile. Furthermore, radial expansion of the liner may further tighten their relationship, and add friction. The total resistance will put the liner in compression, possibly much higher than the mere

weight of a lifted chimney top. If the restraint bears unevenly on different parts of a liner, or there are poor liner joints as described above, the same type of shear stress may cause the liner to fail.

Such damage can be distinguished in several ways. First, it is highly likely that such cracks will be longitudinal and occur *in pairs*. Because the force is imposed differentially to different parts of the liner, it will tend to split the liner into two lengthwise sections, which must be defined by two cracks. Clay flue lining simply will not bend under these circumstances. If there is sufficient stress to cause a crack, it must be matched by another.

Secondly, the two broken sections will most likely be vertically displaced at least slightly. The “desire” of the differential loading is to restrain one part while letting the other move. Once the tile is broken there is no comparable force to move the separated pieces back to their original relationship.

Finally, there is likely to be evidence of crushed mortar between the liner joints. The compressive strength of the masonry mortar commonly used at joints is much less than that of the flue lining: 2000 to 4000 psi. Given the magnitude of the force needed to shear the liner, the mortar is almost certain to have failed first.

Differential thermal expansion is one of the more subtle forces which can be brought to bear on a chimney. That does not necessarily disqualify such a diagnosis, but when there is evidence of a simpler and more direct mode of damage, differential expansion should not be accepted without convincing evidence. The most important task in the analysis is showing how different chimney components were caused to move in such a way that failure stress consistent with the direction of force was able to develop.

Thermal Fatigue Cracking

It has been suggested that the alternate expansion and contraction of a flue liner over years of heating and cooling cycles could cause the liner wall to weaken and fail with the development of cracks. This is not an entirely implausible hypothesis, but essentially no evidence is available to confirm it. There is substantial evidence that repeated episodes of thermal *shock* will cause refractory bricks to lose strength and be

more susceptible to fracture by the application of mechanical stress. It is also known that silicate glasses and oxide ceramics will become progressively weaker under a *static* load because of special corrosion effects at the tips of microscopic cracks.⁷ However, neither the clay products industry nor ceramic theorists would expect repeated heating and cooling in the normal range to produce failure. The possibility is mentioned for completeness.

4.3.2 MOISTURE-RELATED DAMAGE; WEATHERING; FREEZE/THAW DAMAGE

True freeze/thaw damage to flue lining is usually limited to the top portions of a chimney for the obvious reason that exposure conditions are likely to be worse and flue gas temperatures lower, increasing the likelihood of freezing. However, in chimneys that are fully outside the house wall, the possibility of damage further down the flue cannot be entirely eliminated.

Clay linings manufactured according to ASTM standards⁸ have a very low rate of moisture absorption: less than eight percent. This makes them very resistant to penetration by moisture and minimizes the possibility of damage by freezing of imbibed water. However, variability in the extrusion process and temperatures at different locations of the kiln means that a small percentage of liners may be more porous than these standards. Modern manufacturing techniques have substantially decreased this possibility, but older linings may be less moisture resistant. In addition, some lining made primarily for the southern regions of the country may purposely be more porous since freezing is usually less of a problem in the South.

If the top section or two of the flue lining is porous or inadequately fired, substantial moisture from rain or condensate may be absorbed. Upon freeze/thaw cycling, expansions of ice crystals inside the material matrix cause the inner surface to progressively spall or crumble. The resulting damage usually looks like delamination: leaves or flakes sloughed off progressively deeper into the liner wall. This spalling may be confused with that created by a very hot chimney fire, and over a period of time they can become indistinguishable. On close examination, the newly exposed surfaces of thermal spalling will appear sharp and well-defined, and the surface will be hard and clean unless the chimney has been used. Large leaves

of sheared material are likely to be found at the bottom of the chimney. In contrast, spalling induced by moisture will expose a softer more rounded surface which will probably lose more material when scraped. The surface will be stained by moisture or creosote, and the flakes at the bottom of the chimney will generally be small.

It is important to point out that freezing of absorbed moisture does not cause cracking by itself, but very severely damaged tile may eventually crumble.

A second mechanism which can lead to cracking is a result of the presence of moisture in the annular space between liner and brick. The source of moisture is usually a deteriorated chimney crown, but penetration through poor liner joints is also a possibility. If the volume of leakage is substantial and it cannot drain or seep out through the chimney wall, it may accumulate in the annulus. This accumulation requires a dam of some sort – usually a ring of mortar completely bridging the gap at a liner joint. Upon freezing, the water will exert pressure on the outside of the liner as well as on the chimney wall. If the moisture forms a complete ring around the liner, the strains imposed will be nearly equal and opposite, and tension failure of the chimney wall may be more likely than compression failure of the liner. However, the force is often imposed in a limited area along the length of a liner section, so cracking of the liner under shear stress is conceivable. If this form of damage does occur, it is more likely to be a transverse crack running all or partially around the liner circumference. It is not uncommon to observe such a crack within the first foot or so below a chimney crown.

If the moisture is not spread evenly around all sides and the liner is sufficiently restrained on the opposite side, a crack may develop similar to that for the radial thermal expansion described above. This is particularly likely if the restraint is localized at a point (such as broken brick or mortar) in close contact with the liner wall. As with radial expansion, the crack may radiate in several directions from the point of concentrated stress, but may also be transverse or longitudinal.

Qualifying a hypothesis of cracking from frozen moisture requires some route of entry for the water. Deteriorated chimney crowns, which are very common, offer the most natural entrance. When this is the case, it is not unusual for

moisture to have also penetrated directly into the top several courses of brick. This frequently results in a stepped cracking pattern as frozen moisture breaks the bond between brick and mortar. This pattern is typical of parapet walls with broken or inadequate coping.

Condensation Of Flue Gases

Over the past decade or so, increasingly efficient appliances have been connected to masonry chimneys. Whether they burn wood, gas, or liquid fuel, these appliances invariably result in lower operating flue gas temperatures and higher humidity and consequently higher dew-point temperatures. The high thermal mass of chimneys which is advantageous in some respects, resists the rapid warm-up of the flue walls. As a result, a greater volume of condensed moisture is likely to be present for a longer period of time on flue surfaces. *The condensate is likely to carry a variety of contaminant chemicals – creosote from wood, chlorides from the air used in a gas flame, and sulfur compounds from coal or oil.*

Clay flue liners are empirically good conduits for the containment of moisture. After all, they are the same material used for drain and sewer pipe. However, clay flue linings have historically suffered from poor installation practices. Joints between sections are often made of incorrect material which has been poorly formed or struck or not sealed at all. It is not unusual to find the liners horizontally misaligned or tilted to make an offset without a mitered cut. As a result, leakage of condensate has become an increasing problem.

The most common form of condensate damage is also its most common outward sign – wet staining and efflorescence on the exterior chimney wall or on adjacent interior house walls. The moisture will carry contaminant chemicals through the wall and may pick up alkaline salts from the masonry. When the moisture dries on the outside, it leaves behind the crystallized chemicals which are usually white and which may build up to some thickness.

There is currently no compelling evidence that the condensed moisture or dissolved chemicals cause any unique form of cracking or other liner damage. Condensation can be the source of moisture to trigger spalling or freeze cracking of liners or chimney walls. It has also been suggested that the pressure of re-crystallization of salts carried into porous liners can cause the

spalling similar to that induced by freezing. If this were the case, spalling of liners not exposed to cold could be expected. However, the significance of this effect has not received a lot of support, so it may be purely speculative.

The Gas Research Institute has sponsored a tremendous amount of laboratory research into the effects and avoidance of excessive condensation. Work was undertaken at Battelle in Columbus, Ohio to examine the performance and durability of clay flue lining and other lining systems under these conditions. In particular, samples of clay flue lining are to undergo accelerated salt spray testing in a standard spray chamber, using synthetic condensate with extremely high levels of contaminants. This testing should help show whether or not unacceptable moisture or corrosion effects are likely under severe conditions. The results of this testing should now be available.

Differential Moisture Expansion Or Shrinkage

Differential movements due to moisture changes should be subject to the same scrutiny described above for differential thermal expansion. Such imprecise diagnoses are often a fallback position for investigators unable or unwilling to consider a more conventional explanation. However, in this case such a contention is even more dubious and requires a correspondingly higher standard of evidence to be plausible.

In fired clay products such as brick or flue lining, moisture movement is one-way, moisture expansion is non-reversible,⁶ and shrinkage is not an issue. Masonry walls will grow in length as moisture is absorbed, but will not contract upon drying. This is one reason, along with increased bond strength, that bricks are supposed to be laid nearly saturated with water – they will be closer to their ultimate dimensions. The generally accepted engineering factor for moisture expansion of brick is .0002 (.02%).⁹ A 100 foot long wall could be expected to expand a total of .24 inch. A relatively wide five-foot chimney wall would become .012 inch (.3 millimeter) longer.

Almost all moisture expansion takes place in the first year or two after construction. When bricks or clay lining are first removed from the kiln, they are as small as they are ever going to be. After being put in place, about 30 percent of their total lifetime expansion takes place in the first month and about 60 percent in the first year. After this initial adjustment, moisture expansion ceases to

be a factor. Any distress which occurs after the first year or two is unlikely to be related to moisture.⁶

Thus it is extremely difficult to imagine circumstances where differential moisture movements in a brick chimney would develop failure stress in a clay flue lining. Both the liner and surrounding brick enclosure would expand in the same direction – outward – and even if the liner were substantially wetter the differential would be microscopic. Compared to the other demonstrably greater and more documentable forces to which a chimney is exposed, moisture expansion offers a less-than-compelling explanation for damage.

Concrete masonry units do both expand and shrink in response to changes in moisture. Shrinkage is one of the more common causes of the development of cracks in basement and foundation walls.⁵ It might thus be suggested that a wet, expanding flue liner might be overstressed by its surrounding dry shrinking concrete block wall. Aside from the need to show intimate contact between the two, consideration of the scale involved puts this possibility in perspective. A shrinkage coefficient of .0005 (.05%) applied to a five-foot chimney wall gives a total of .03 inches, or .762 mm. To the extent that this movement is directed toward the liner, it also produces tensile stress on the block which would be at least as likely to fail. Thus, even under the most extreme and improbable conditions, *moisture shrinkage is a dubious explanation for flue liner damage.*

As with temperature movements, moisture movements will not be summarily rejected as a cause simply because of their improbability. It is possible that the two types of differential movements could occur in combination, thus developing stress greater than either effect alone. However, especially when evidence of a simpler cause is available, such a diagnosis should be supported by compelling unambiguous evidence and perhaps a thorough quantitative engineering analysis.

4.3.3 SETTLEMENT

Settlement is an overly-used diagnosis of distress in masonry structures of all types,^{5,6,8} including chimneys. It is subject to the same misuse as are thermal and moisture movement – a conveniently

general explanation to cover failure to identify a specific cause. However, movements of foundations relative to the earth do occur, and they are at least less subtle and thus more verifiable than more imperceptible movements.

As with all damage diagnosis, an important element is the establishment of a connection between the force and the damage. Even where settlement is obvious, it must be possible to trace a path of movement or stress from the ground to the point of interest. Without such a link, settlement may be interesting and of concern for the damage it causes directly, but not necessarily for all damage found throughout the chimney.

Settlement takes different forms, some of which carry more potential for damage than others. The type of movement that will occur depends mostly on the construction of the chimney foundation or footing. If it was built too thin, it may crack. If it is not wide enough, it may not adequately distribute the weight. If it is not built below the frost line, it may be subject to heaving. If the chimney is not carried on the same foundation as the house, the likelihood of differential movement increases. When the chimney is founded on backfill from excavation of the house foundation rather than on undisturbed earth, some movement is almost certain.

Uniform settlement, where everything sinks straight down into the ground, may be of no concern at all unless it is different from the settlement of the adjacent house. In such cases, the interface between the chimney and house may be stressed, and a shear crack may develop where they intersect. The most dramatic form of this is found in houses with overlapping bricks. Since the chimney in such houses is usually built on the same foundation, this is rather rare. At any rate, uniform settlement carries less potential for damage to the chimney or its liner.

Two types of settlement do represent a greater likelihood of chimney damage: *rotational* and *differential* settlement.

Rotational Settlement

Rotational settlement results when one side of the footing settles relative to the other sides but without the development of a crack between the two. The foundation and the chimney above it are tilted or rotated in one direction or the other. Most commonly, the chimney falls away from the

house, in which case the most likely development is a gap, wider at the top, between house and chimney walls. In other cases, the chimney rotates in one direction or the other parallel to the house wall. This can usually be identified by an exposed unpainted or unsided sliver of the house wall adjacent to the chimney, again wider at the top. With somewhat less certainty, rotational settlement can be identified by holding a plumb line from the top – as long as the chimney was not built out of plumb!

If the chimney is able to rotate as a unit, no actual problem should result other than the architectural discontinuity, but it is not uncommon for there to be some restraint of the free movement of some part of the chimney. The chimney may be tied to the house wall, or, as in the case of fireplaces, built into the wall. The penetration through the soffit or eaves may be tight enough to prevent any sideways movement of the top portion of the chimney. The exact mode of restraint depends on construction details, but some restraint can often be identified.

The way that such restrained movement translates into damage can also vary with the details involved, so no attempt will be made here to catalog all the possibilities. The most general form, however, results from the formation of a hinge between the lower moving parts and an upper restrained section. It should be possible to identify a horizontal gap, almost certainly in a bed joint, on the side of the chimney which has sunk. The gap should get progressively thinner on the face toward the other side and eventually disappear. In some cases, this may not be a single gap, but instead be a series of smaller horizontal cracks which together add up to the difference between the rotated and stable sections of the chimney. It may be possible to identify this effect and the location of the hinge by sighting up a corner of the chimney.

If the hinge point occurs in a lined portion of the chimney, and the liner is locked in a tight relationship with the chimney wall, the liner may be fractured much like bending a dry stick. If the bending is severe, the liner may be simply shattered into many pieces; otherwise, one or more transverse cracks are more likely. The damage is most likely to be concentrated at the hinge area rather than spread throughout the liner.

The upper portion of the chimney may not be

affected by the development of a gap. On the other hand, the uneven support from one side to the other may cause the heavy unsupported side to sag and a shear break to develop between the two sides. The resulting crack should have several characteristics – 1) it should more or less follow head and bed mortar joints, but it may occasionally cut through a masonry unit; 2) it should be generally diagonal, will probably extend all the way to a corner of the chimney, and should be wider at one end or the other. There should also be some vertical displacement of the unsupported wall relative to the other wall.

If the shear is extensive enough and, again, the liner is intimately connected to the chimney wall, a series of longitudinal cracks may develop in one or more sections of the liner. These may be in addition to cracks caused by the hinge and must almost certainly be above it. *As with restrained axial thermal expansion, the liners are most likely to be split into two sections which will be displaced in the same way as the chimney wall.*

Restrained rotational settlement may have other consequences and other damage patterns in different situations. The path of damage can usually be traced by identifying the area where stress has damaged the chimney wall. Any damage to the liner should make sense from the standpoint of the direction of movement of the chimney.

Differential Settlement

Differential settlement occurs when one part of the chimney footing settles relative to the other, and a break develops between the two. The moving portion may rotate, as described above, or may settle straight down. This form of settling is fairly rare in chimneys for an obvious reason. A foundation is, quite literally, a beam spanning the earth below. Just as it is relatively difficult to bend or break a short beam, the short span of a chimney foundation compared to a house foundation makes failure less likely. However, wide chimneys (such as those with fireplaces) or foundations built on unstable earth may develop this problem.

An almost inescapable sign of differential settlement is that damage to the chimney must originate from the ground – it can't float somewhere up in the chimney without connection to the broken foundation. Bricks above cannot

move and develop cracks unless the bricks below move and develop cracks. About the only possible exception to this would be if the movement occurs over a long period of time – probably decades – such that plastic deformation of the masonry could take place. If this occurs, portions of the wall can bend, but not break under the stress. This should be apparent from sighting along horizontal bed joints – they will be gradually curved rather than straight. Except in these cases, however, it should be possible to trace a crack, at least a hairline, to the crack in the foundation itself.

Any such crack or cracks in the chimney wall will display the same characteristics as those described for the shear cracks from rotational settlement. If the center of the foundation is settling relative to the ends, a crack is most likely to be at the center, wider at ground level, and diminishing to nothing further up. It may be fairly vertical or follow a diagonal path through mortar joints. If one or both ends of the chimney are falling relative to the center, a diagonal, stepped crack following mortar joints toward the center of the chimney is most likely. Again, the crack will be widest at the bottom and increasingly narrower further from the edge. If one whole end of the chimney is falling away from the other end, a diagonal crack may start from the center and work toward the side of the chimney further up. This is the only case where a crack is likely to be wider toward the top and thinnest near ground level.

Damage to the chimney liner can take the same forms described for rotational settling – transverse cracks in bending or longitudinal cracks in shear. However, it is important to show how movement at the ground translated into stress on the liners. For instance, in a fireplace chimney where the damage corresponds to the location of the fireplace and smoke chamber, there is no reason to assume that the lined chimney above has been subjected to differential movement. It may have been, but some physical evidence or other reason to believe should be produced.

Whatever the nature of the settlement, it should be remembered that the chimney carries the liner, not vice versa. Damage to the chimney must almost certainly precede damage to the liner. If damage to the liner is suspected to be due to settlement, it should have a reference to some form of damage to the chimney wall. Secondly, damage to the chimney does not necessitate damage to the liner.

There must be a means for bringing the strain of foundation movement into contact with the liner in a way that causes failure. If the liner and chimney wall are constructed separately and with the air space called for by most codes, they will be more able to function and move independently, and the risk of liner damage will decrease, but it may not be entirely eliminated.

4.3.4 MISCELLANEOUS MOVEMENTS OF CHIMNEY

A variety of other movements have occasionally been observed which possibly could result in damage to the chimney or liner. Most common is rotation of one level of the chimney relative to another for reasons other than rotational settlement. This usually occurs when moisture penetrates poor mortar joints on the chimney sides. The contrasting effects of sun and freezing on different sides of the chimney results in progressive ratcheting of the chimney. The top may curve or lean relative to the stable base. In general, the tilt is toward the warm side, i.e., south or west. The chimney is bending like a green stick, but the brittle liner inside may not follow along.

Especially tall chimneys with a large unsupported stretch above the roof may be subject to wind loading. This can be either a constant load pushing the chimney in one direction or result in a harmonic sway like a metronome. Wind damage after such events as hurricanes and tornadoes is common. In either case, cracks can develop in bed joints, and ratcheting can occur if debris enters while a crack is open.

Finally, earthquakes damage chimneys. Although a tightly-filled annular space between liner and chimney has been cited as contributing to damage from the causes cited above, building codes in the western United States require this feature, together with integral reinforcing rods. Apparently the possibility of a chimney toppling over during an earthquake overrides concern for the increased likelihood of liner damage.

NOTES

1. *A Pocket Guide to Arson Investigation*, Factory Mutual Engineering Corp., 1979.
2. Dennis Brosnan & John P. Sanders III, *Fireplace Mortars*, Clemson University, Center for Engineering Ceramic Manufacturing, Clemson, SC, July, 1990.

3. Philip Schaenman and Charles Feldman, *The Wood Heating Alliance's National Survey of Chimney Fires, Year 2 – 1988/99*, TriData Corporation, July, 1989.
4. Nolan Mitchell, "Fire Hazard Tests with Masonry Chimneys," *NFPA Quarterly*, National Fire Protection Assn., October, 1949.
5. Edgar O. Seaquist, *Diagnosing and Repairing House Structure Problems*, McGraw-Hill, Inc., 1980.
6. *Technical Notes on Brick Construction*, No.18, "Differential Movement," Brick Industry of America, Reston, VA, July, 1984.
7. W. D. Kingery, *Introduction to Ceramics*, John Wiley & Sons, New York, 1960.
8. ASTM C 315 – 07, *Standard Specification for Clay Flue Linings*, American Society for Testing and Materials, Philadelphia, PA, 1987.
9. Jerry G. Stockbridge, Wiss, Janney, Elstner Associates, Inc., Northbrook, Illinois, personal communication, January 9, 1992.

Chapter 5:

Application of Insurance to Chimney Fire Damage

5.0 INTRODUCTION

Previous chapters have described chimney fires, the mechanisms by which they cause damage to masonry chimneys and techniques for identifying such damage in actual chimneys. Since the cost to repair chimney fire damage can often run into the thousands of dollars, homeowners faced with such a loss often turn to their property insurance company. Since coverage for damage caused by fire is an essential part of most homeowners' insurance policies, such claims have generally been paid with little or no hesitation. However, on occasion an insurer will question the validity of the claim or deny it outright.

Historically, insurance claims for fire damage have been a reasonably straightforward matter. The occurrence of a fire and existence of damage is usually not in question, and, while a dispute may arise over the amount of loss, the applicability of coverage is not usually an issue. Chimney fires, however, are a unique phenomenon, and the applicability and criteria for coverage is not always immediately apparent. While the accidental burning of combustion by-products in chimney flues is not a new hazard, it has become common only over the last few decades or so, and most people are not familiar with their causes and effects. After all, a chimney fire burns in a concealed area which is constructed of non-combustible materials intended to be in contact with smoke and a certain amount of heat. It is understandable that some might not intuitively grasp a chimney fire's significance, in contrast to obvious "traditional" fire damage.

It appears that the insurance approach to chimney fires is not a settled matter because there is a clear lack of uniformity and predictability in the way such claims are handled. The principles of fire insurance are well established, however, and the means are available for applying them to this relatively unique fire phenomenon. The purpose of this chapter is to explore the provisions of standard homeowners' policies and their application to chimney fires. It is expected that this effort will contribute to a better understanding of the criteria for evaluating claims, the distinctions between valid and invalid claims, and

the fair and expeditious adjustment of valid claims.

In addition to the homeowners policies themselves, the primary reference for this chapter is *Fire, Casualty & Surety Bulletins* (FC&S Bulletins),¹ one of the most authoritative and up-to-date resources available. The Chimney Safety Institute of America wishes to thank Mr. Michael K. McCracken, CPCU, Assistant Editor of FC&S Bulletins, for his special assistance in this project. As the designated authority on property coverage, Mr. McCracken helped interpret the applicability of fire coverage to chimney fires and commented on specific problems in claims evaluation and loss settlement.

5.1 HOMEOWNERS POLICIES

The practice of insurance goes back many years, but until relatively recently insurance policies were little more than agreements among groups of individuals. Such relatively simple agreements could be based as much on informal understandings as on the specific language of the policy. They could be developed essentially on a custom basis depending on the needs of the parties involved.

As both society and the insurance business became more sophisticated, the need for standardization of policies became more important. Agreements among neighbors became contracts between strangers, and unwritten understandings need to be replaced with language clearly expressing the responsibilities of each. It became paramount that the words of the policy mean the same to each party and convey the same intent from policy to policy. Creation of common understanding and interpretation of the purpose and terms of insurance necessitated the development of standard policy forms that could be applied universally and consistently.

The first standard property insurance policies which addressed the primary hazard of fire became available in the late 19th century. Initially, standard policies were produced on a state-by-state basis, but by the early 20th century more uniformity among the state-mandated policies began to evolve. New York State came to be used

by more states than by any other, and, through several revisions, emerged as the nearly universal basis for fire policies everywhere.

The latest version of the New York policy, or as it is more commonly known, the Standard Fire Insurance Policy, was developed in 1943 and is now used with minor variations in nearly all states. It has been superseded by package policies that cover a variety of perils, so it is not usually the actual contract signed by the insurer and the insured. It does, however, set forth the principles and many of the actual terms and conditions that are found in most of the property insurance packages, including the now-predominant homeowner's policies.²

The Standard Fire policy itself covers only the peril of fire and does not address other possible sources of loss to property. However, additional coverages could be added to the basic policy by endorsement – the attachment of supplemental forms subject to the overall conditions of the policy plus any specific conditions related to the specific peril. During the 1930's and 40's, the more common additional forms were gathered together into a package called "extended coverage" which could be added as a unit to the basic policy to form reasonably comprehensive protection against a variety of causes of loss. Extended coverage included insurance for the perils of *windstorm or hail, explosion, riot, civil commotion, and damage by aircraft, vehicles, and smoke*.³

Extended coverage policies were still general enough that they could be applied to a variety of different types of buildings and occupancies. A shopkeeper might have essentially the same property policy for his store building as for his home. Many hazards are common to all buildings, but it is equally clear that dwellings and commercial properties are exposed to other perils which represent different risks of exposure, frequency, or severity. Homeowners are also willing to buy coverage that would be less attractive to store owners, and vice versa.

During the 1950's, the evolution of extended coverage policies lead naturally to the development of standard policies specially designed for the needs and desires of owners and occupants of dwellings. These original homeowner's policies combined a variety of coverages that were previously available only

through special endorsements, separate policies, or not at all. A homeowner could now be offered a single instrument which addressed the sources of potential loss which are most troublesome for residential properties.

The homeowner's policies used during the 1950's, 60's, and early 70's were still written in the formal legal language for which insurance policies are infamous. Naturally, this lead to frequent misunderstanding between insurer and insured and bitterly disappointed policyholders who found that the inscrutable language actually excluded a loss they had assumed was covered. Where the Standard Fire policy was at least short and straightforward, homeowner's policies were so comprehensive in their coverage that they had become long and complex, with frequent cross-references and detailed conditions. The common understanding of the purpose and conditions of insurance, which was the goal of standardized policies, did not include the policyholder.

In 1976, the Insurance Services Office (ISO) responded to this problem with the introduction of a series of simplified-language homeowners' policies which helped bridge the gap of understanding. The new forms attempted to replace the stilted words and sentence structure of traditional policies with commonly-understood terms and a more concise presentation. The standard forms were printed in 25 percent larger type size and the overall length was reduced from more than 12,000 words to fewer than 7,000. Indicative of the overall effort to make the policy more accessible and personal, the forms referred to the policyholder as "you" and the insurance company as "we."⁴

Although for the most part it was not the intent to change the meaning of policy provisions, the translation into simplified language inevitably caused differences in interpretations of the new words. The traditional language, while difficult for the average reader, had been interpreted by the courts many times over the years to the point where its meaning was fairly well established. In some cases the change in language had the effect of removing the precedent of earlier decisions, so the courts had to start from scratch to interpret the meaning of the new language. The result has been that sometimes the courts have found broader coverage than was intended when the policies were drafted and the premiums were calculated.

Both to adjust the language and to respond to the changing exposures in the residential landscape, the homeowner's policies have been updated several times since their introduction – in 1982, 1984, and again in 1991. The changes in all cases have both liberalized and restricted coverage, depending on the circumstances. Because the newly included has been balanced by the newly excluded, the net effect has been no change in the overall exposure or basic rate structure of the homeowner's policy program.

The simplified language homeowners' program has been so successful that it has been adopted by nearly all states, fully replacing the old Standard Fire plus extended coverage approach (Texas has its own homeowners policy, and California has, to date, stuck with the 1976 version). By far the most common form of insurance for owner/occupants of one- and two-family dwellings is one of the forms of the homeowner's series. Some of the largest national insurers have developed their own homeowner's forms which are used instead of the standard ISO documents. However, these are generally very similar to the ISO model, and a discussion of the standard forms will apply in most important respects to the policies held by most residential property owners. The focus of coverage and its broadness varies with the specific form, but the standardization of residential insurance makes possible a discussion of insurance principles and their application to chimney fires.

5.1.1 HOMEOWNERS FORMS

The current ISO Homeowners program includes six standard policy forms:⁵

- HO-1** Very basic coverage; being withdrawn from many areas
- HO-2** Broad form; named perils
- HO-3** Broad form; open perils
- HO-4** Broad form for contents (personal property)
- HO-6** Unit owners (condominiums, etc.)
- HO-8** Actual cash value coverage

Of these, the most important for a discussion of chimney fires are forms HO-2 and HO-3. Together they represent the vast majority of one- and two-family detached dwellings which contain masonry chimneys and, therefore, exposure to the possibility of a chimney fire. Both provide the same general *level* of coverage but differ

significantly in the way they define the perils insured against. The difference does not directly affect coverage for damage caused by a chimney fire, but it can influence the ease with which a loss is adjusted and the ways in which evidence is weighed.

The HO-2 form is a "named perils" policy, i.e., it lists the specific causes of loss which are insured against, and coverage is strictly limited to those listed. If a particular source of damage does not fall into one of the categories stated in the policy, it will not be covered no matter how sudden or accidental. An HO-3 form is an "open perils" (formerly called "all risks") policy because it insures against *any* cause of loss *except* those that are specifically excluded. Any loss, for whatever reason, not reached by exclusion is automatically covered.

The most common types of loss are covered by both policies because they are either listed in an HO-2 form or not listed among the exceptions to the HO-3 policy, but the open perils policy provides coverage for unusual or exceptional circumstances that cannot be anticipated in any finite list. It also provides broader coverage for some cases where damage ensues from a non-excluded event even when an excluded cause is also involved. Any damage caused directly by the non-covered source is still not covered, but any ensuing damage that is not otherwise excluded is covered.⁶

A second implication of the difference between the policies is more subtle. As will be discussed more fully in a later section, the burden of proof always rests with the insurance company to show that a particular loss is not covered, regardless of the policy. Under an HO-2 policy, however, the company must only demonstrate that the cause of the loss is not among the listed perils. While it is always helpful to show what *did* cause the loss, this is less critical with the named perils form. It is only strictly necessary to show that, whatever the cause of loss; it could not have been one of those listed.

In the case of an open perils policy, the insurer must show with reasonable certainty that the specific cause of loss is reached by a specific exclusion. Unless it can be demonstrated that the cause is excluded, it is presumed that the cause is not excluded. Consequently, the burden of determining the actual chain of causation weighs

more heavily on the insurance company. With any policy, the benefit of any uncertainty accrues to the policyholder. Uncertainty is more likely with an HO-3 policy.

5.1.2 POLICY PROVISIONS

Both policies are organized in the same fashion, both cover the same types of property, and both are subject to the same sets of conditions. The first page of a policy is the “Declarations Page” which is a cover page for the standardized preprinted policy which follows. The Declarations Page sets forth the business agreement between the company and the policyholder – the amount of insurance, the policy period, deductible and premium amounts, among other things.

The standardized homeowners form begins with an Agreement which simply says that the described insurance will be provided in return for premium payment and compliance with the terms of the policy. A Definitions section follows in which certain words that are used in the policy and have critical meaning for its interpretation are defined.

The policy is then divided into two Sections. Section I covers the property of the insured, and Section II covers liability to others that might arise out of events that occur on the insured’s property. Each of these Sections includes portions which describe the coverages, exclusions, and conditions for each type of insurance. Finally, a set of global Conditions which are applicable to both Sections I and II are set forth at the end of the policy.

Since Section II – Liability – is unlikely to have any bearing on chimney fires, we will summarize only the provisions of Section I – Property. The first part of Section I describes coverage for the different types of property which make up a home. Coverage A is the dwelling itself which includes the main building in which people live and any structures attached to it. Coverage B is for other structures located on the residence premises, separated by a clear space from the dwelling but not used for business or rental to others. Coverage C is for personal property owned or used by the insured. This property is covered anywhere in the world but is subject to special limitations for specific types of property. Coverage D is for Loss of Use – the financial burden on the insured resulting from the inability

to live in or use property damaged by a cause covered by the policy.

A set of miscellaneous Additional Coverages are also provided. These include the costs of removing the debris of destroyed property from a loss; repairs needed to protect property from further loss; fire department service charges incurred; and damage to trees, shrubs, and other plants, among other things. An additional coverage for collapse of a building or part of a building, with very specific limitations, concludes this section.

5.1.3 PERILS INSURED AGAINST

The next part of both HO-2 and HO-3 policies describes the Perils Insured Against. All other parts of both policies are nearly identical, but this part is entirely different in each policy. The differences between the named perils HO-2 and the open perils HO-3 policies can best be illustrated by comparing their introductory paragraphs:

HO-2:

We insure for direct physical loss to the property described in Coverages A, B and C caused by a peril listed below unless the loss is excluded in, Section I – Exclusions.

(List of covered perils follows)

HO-3:

We insure against risks direct loss to property described in Coverages A and B only if that loss is a physical loss to property; however we do not insure loss: (List of exceptions follows)

Note that the HO-3 policy does not extend open perils coverage to Coverage C – Personal Property. A separate section with language identical to the HO-2 treatment gives named perils coverage to personal property. Thus the policy might cover a loss to building from an unexcluded cause, but not to its contents unless the cause is also listed among the named perils. However, open perils coverage for personal property can be purchased separately by endorsement.

In both policies, the insurance is against “direct physical loss to property.” Although its interpretation would appear to be crucial to some claims, this term is not defined in the definitions section. (Definitions are included for

“occurrence” and “property damage,” but these terms are used only in Section II – Liability and therefore have no relevance to the property coverages.) When a term is not specifically defined in the policy, it is used with its conventional meaning or dictionary definition. Therefore, there must simply be physical damage to covered property which can be linked by causation directly to a covered peril. Note also that there is no qualification for the *degree or extent* of damage. Any damage caused by a covered peril is insured against.

Since it is the intent of both policies to provide the same general level of coverage, their respective Perils Insured Against sections are mostly two sides of the same coin. Perils listed in the HO-2 policy are not excluded by the HO-3 policy, and a few things not included in the HO-2 list are specifically included in the HO-3 list of exclusions. A large number of circumstances are specifically excluded by the language of both policies. These can be summarized as “smoke from agricultural smudging or industrial operation; theft from a building under construction or of building materials; vandalism or glass breakage beyond a vacancy period of 30 days; water leakage over a period of weeks, months, or years; freezing, thawing, or pressure or weight of ice or water to a fence, pavement, patio, etc.; and freezing losses while the dwelling is vacant, unoccupied, or being constructed unless the insured has taken steps to guard against such a loss.”⁷

In addition to these exceptions, the HO-3 policy contains a group of exclusions which make it clear that even open perils coverage does not insure against things that are certain to happen over a period of time or things that can be prevented with reasonable care. These are the exclusions for:

- (1) wear and tear, marring, deterioration;
- (2) inherent vice, latent defect, mechanical breakdown;
- (3) smog, rust, mold, wet or dry rot;
- (4) smoke from agricultural smudging or industrial operations;
- (5) release, discharge, or dispersal of contaminants or pollutants;
- (6) settling, cracking, shrinking, bulging, or expansion of pavements, patios, foundations, walls, floors, roofs, or ceilings; or
- (7) birds, vermin, rodents, insects, or domestic animals.

The meaning of these exclusions is frequently a source of confusion, and they are sometimes used to deny claims which actually do fall within the intent of the insurance contract. The following excerpt from FC&S Bulletins provides the clearest explanation of their proper use:

“The application of any of these exclusions should be governed by the intent behind the entire list – to reinforce the policy’s function as a source of protection from *accidental* loss. Homeowners insurance is not intended to cover the wear and tear or gradual marring that wood furniture or kitchen counter tops, for example, are subjected to. But when an unexcluded, accidental cause of loss results in sudden damage to such property – a heavy object dropped on the counter top and cracking it, for instance – the wear and tear or marring exclusion is not appropriately applicable to such damage. Similarly, damage from moisture that collects in a newly built house because of a defect in construction methods might be termed “mold” or “wet rot.” But it would not be the kind of damage that is *certain* to occur in damp and unventilated space and that is the proper subject of the “mold; wet or dry rot” exclusionary language. In such a case, the cost of correcting the faulty construction – a “latent defect” – would not be covered by homeowners insurance, but loss by moisture – *accidental* damage caused by the latent defect – would be covered by insurance when written on an *open perils* basis.”⁸

While open perils policies exclude coverage for damage caused directly by one of the above causes, they do cover any “ensuing loss to property” so long as that type of loss is not also excluded or excepted. For instance, if a furnace gradually deteriorates and a fire in the structure then results, the deterioration of the furnace itself is not covered, but all of the loss from the ensuing fire is, under an open perils policy.

5.1.4 EXCLUSIONS

In addition to the exceptions expressed in the Perils Insured Against section, both policies contain an Exclusions section that applies in general to all the property coverages. Both forms contain eight exclusions for such things as enforcement of an ordinance or law, earthquakes, floods, off-premises power failure, failure to protect property during and after a loss, war and nuclear hazard, and intentional losses. The HO-3 policy contains several additional exclusions

designed to eliminate coverage for losses due to certain combinations of covered and non-covered causes. Such “concurrent causation” cases had been leading to unintended coverage for such things as earth movement despite the clear intent of the policy to exclude them. These new exclusions do not affect losses caused directly by a covered peril, nor do they prevent coverage for damage which ensues from a concurrently caused loss.

Sometimes confusion exists over the implications of the “ordinance of law” exclusion. It is primarily designed to protect the insurance company from paying for the increased costs of rebuilding, repairing, or demolishing a damaged building that might arise from compliance with zoning or building regulations. It does not affect the validity of a claim for damage caused by a covered peril, but it may limit the amount needed to comply with the law.

If property is damaged by some covered peril, it may no longer be in compliance with codes or standards that regulate the construction or condition of structures. The fact that an ordinance or law may require damaged property to be repaired or replaced is not the cause of loss – the covered peril was the cause, and the validity of the claim is not reduced. However, if the law requires some additional demolition or construction features that would not otherwise be necessary to repair the damage itself, such additional loss is not covered. A fairly common example is when a building was constructed according to codes in effect at the time. If a loss occurs, rebuilding will have to be done according to current codes. Any extra cost of such enhanced construction over and above the cost of reproducing the original features will not be borne by the insurance company.

This is not intended to open the door to substandard or slipshod repairs. The language of the policy in no way reduces the obligation of the company to pay the full cost of repairing or replacing property damaged by a covered loss, including the cost of doing it right. The exclusion applies only to a loss or the part of a loss which resulted from the enforcement of a law or ordinance. Any repairs that are paid for under the policy should be done according to any applicable codes and to standards of good workmanship. While it may be possible to find a contractor willing to perform repairs for a lower price but not in compliance with codes (especially in areas with

lax or nonexistent code enforcement), this is not the intent of the “ordinance or law” exclusion. The policyholder has a right to restoration of property to safe and functional condition and is not required to accept substandard work just because proper workmanship in compliance with applicable codes costs more.

5.1.5 CONDITIONS

The Section I – Conditions section sets forth the rules under which losses are settled. The duties of the insured following a loss are described, as are the maximum liability of the insurance company and the methods of calculating the amount of the settlement that will be paid. If the policyholder and the company do not reach an agreement on the amount of loss, an appraisal procedure is available. Other paragraphs cover loss to a pair or set; replacement of glass; handling of losses covered by more than one policy; limits on bringing suit, who is paid and in what time frame; the insurance company’s option to repair or replace property; and how recovered stolen property, nuclear hazards, and volcanic eruptions will be handled.

The duties of the insured with respect to a loss to a building are fairly simple but important. The insurance company or its agent must be notified “promptly” after a loss. The policy is silent about situations where the loss is not detected until sometime after its actual occurrence, and the individual states may have statutes of limitations which define “promptly.” In general, the application of this condition depends on the circumstances of the particular case. The insured should always exercise due diligence in reporting a claim, but the courts have been willing to consider extenuating circumstances in evaluating the promptness of notification.

The insured must also take reasonable steps to protect the property from further damage during and after a loss and keep a record of expenses. As often as the company reasonably requires, the insured must be willing to show the damaged property and answer questions, including under oath. Finally, within 60 days of the insurance company’s request, the insured must submit a signed and sworn proof of loss which give the time and cause of loss, a description of the damage with repair estimates, and supporting evidence, among other things.

Losses to personal property are settled according to their actual cash value, which is their replacement cost less depreciation, or fair market value at the time of the loss (unless an optional endorsement for replacement cost has been purchased). In other words, the settlement for personal property will not necessarily be equal to its original purchase price nor fully cover the cost of repair or replacement. In contrast, buildings under Coverages A and B are valued at their full replacement cost without deduction for depreciation (so long as the amount of insurance in effect is at least 80 percent of the building's replacement cost.) The insurance company "will pay the full amount necessary to repair or replace the damaged property, but not more than the least of the following amounts:

- (a) the limit of liability under this policy that applies to the building;
- (b) the replacement cost of that part of the building damaged for like construction and use on the same premises; or
- (c) the necessary amount actually spent to repair or replace the damaged building."⁹

For partial losses which don't destroy the whole building, settlement is usually based on (b) or (c). For practical purposes, these are usually the same amount, i.e., the amount actually spent on repairs is equal to the replacement cost. Note, however, that the replacement cost is based on the cost of equivalent construction on the same premises. The reconstructed property does not need to be identical to the original nor even located at the same place, but the amount of the settlement will be based on what it would cost to restore the property to its original status, at the same location.

Because the settlement is keyed to the replacement cost rather than the actual cash value, the condition of the property prior to the damage is irrelevant. Regardless of whether the property was deteriorated or previously damaged or brand new, the settlement must be based on the current cost of creating an equivalent structure. In some cases, the materials originally used may be outdated or no longer available. In such cases, restoration of the function or purpose of the original construction is paramount, and the settlement is properly based on the cost of repair or replacement using modern materials.

If the company and the policyholder are unable to agree on a settlement, the homeowner's policy

provides a method of appraisal which is activated upon the demand of either party. Each party will choose and pay its own appraiser. The two appraisers then agree upon an umpire (or, if necessary, have one chosen by a court). The appraisers then separately set the amount of loss. If they do not agree, they will submit their differences to the umpire. Agreement by any two of the three will fix the amount of loss. The expenses of the appraisal and the umpire are split between the two parties.

Technically, the purpose of appraisal is only to produce an agreement about an amount of loss. It is not meant to arbitrate disputes about the validity of a claim, nor are the appraisers or umpire supposed to consider the terms of the policy in making their determination. Their job is simply to appraise the monetary value of the loss suffered by the insured, once coverage for the damage has been confirmed.¹⁰

However, an identical method is sometimes used as an arbitration procedure to resolve questions about the applicability of coverage. Even though this distinction is not actually recognized in the policy, arbitration can be a useful extension of good-faith negotiation by both parties. It provides a less expensive route to resolution than a lawsuit, particularly where the amount of loss is relatively small. Unless the parties agree that the arbitration will be binding, the implementation of this procedure does not preclude the policyholder from later bringing suit, if he is still dissatisfied. However, the policy states that any suit must be brought within 12 months of the date of the loss.

5.2 COVERAGE UNDER FIRE PERIL

Since the homeowners program was formed around the core of the old Standard Fire policy, it is not surprising that fire is the primary and least ambiguous of the perils covered by both HO-2 and HO-3 policies. "Fire or Lightning" is the first peril mentioned in the HO-2 list of those covered, and no form or type of fire is excluded by HO-3 policies. There is no qualifying language attached to the fire peril. Property damaged by fire appears to be simply covered without exception.

However, the concept of "fire" as a physical phenomenon is not necessarily the same as its meaning as an insurable peril, so some discussion of its practical application is warranted. In Chapter 2, a definition of fire was offered. Fire

essentially means rapid oxidation accompanied by the generation of heat and light in the form of flame or glow. For some insurance purposes, a third qualification needs to be added: the fire must be hostile in nature.

Fire is used for a wide variety of civilized purposes, and when it is simply doing its normal proper job, it is not considered a hostile element. A fire that is accidental in nature or is not located in a place that is normally expected to contain fire is no longer a civilized force and has become the subject of all policies that insure against fire. The same principle applies to the products of combustion – heat and smoke. When given off by a “friendly” fire, these products are considered the inevitable result of the proper use of fire, but damage caused by heat or smoke from a hostile fire is covered by the fire peril. (However, smoke damage from most sources is covered separately under the smoke peril.)

The easiest way to define “hostile” fire is by fixing the essential characteristics of a fire that is not hostile. A “friendly fire” is one that has been intentionally kindled and has remained confined to the place where it was intended to be. Both of these qualifications must be met in order for a fire to be considered friendly. If either ceases to be true, the fire has become hostile. Even a fire started initially for a friendly purpose is hostile if it spreads to a place not intended to contain fire.

Despite the importance of the location of the fire, the courts are increasingly willing to construe an excessive fire as hostile even if the combustion process never actually leaves the place where it was kindled. Numerous cases involving the malfunction of automatic controls, and thus allowing a heating device to overheat or not shut off, have been decided in favor of a more liberal interpretation of hostile fire. Under this extension, even objects that are intended to be in contact with a normal fire or the heat given off by that fire are covered by the fire peril if they become damaged by an unusually hot or abnormal fire.¹¹ In other words, the location of the fire cannot be considered apart from its nature. If the fire contains the essential element of accident in its kindling, its spread or its intensity, it is the proper subject of insurance.

It should also be noted that if a fire does escape its intended confines, its degree or intensity becomes irrelevant. A fire cannot be a little hostile or

merely grumpy. It does not have to reach a particular temperature in order to be considered a hostile force. Any damage resulting from an escaped fire is fire damage, whether the damage is widespread or merely “cosmetic.” This is true even if the damaged object can theoretically withstand some degree of fire – if it is not intended to contact fire, any fire which reaches it is hostile. *The test of fire insurance coverage is the nature of the peril as an accidental unintentional occurrence, not its severity or theoretical potential for damage.*

By the same token, insurable damage from fire is not limited to some specific set of phenomena. While fire damage is most easily recognized as scorched or “burned up” combustible material, fire can also cause warping, cracking, spalling, blistering, melting, boiling, rupture, etc., even to objects which are not themselves combustible. The damaged object need not have come in contact with actual combustion – if the fire meets the definition of hostile, its entire range of effects are eligible for coverage as fire damage. In addition, any damage caused by efforts to extinguish a fire is covered under the fire peril. Neither the degree of damage nor its theoretical effect on the serviceability of the property is relevant – if property is physically damaged, a loss has been suffered.

While the distinction between hostile and friendly fire is important for named perils policies such as the HO-2, the concept has no application to insurance written on an open perils basis, such as HO-3. As pointed out by FC&S Bulletins, “since these policies are not restricted to damage by ‘fire’, it is obvious that – unless some specific exclusion reaches a loss – it makes no difference whether a fire that damages insured property is ‘friendly’ or ‘hostile’.”¹² However, it is still true that the fire must contain some element of accident. As discussed in the previous section, open perils policies contain an exclusion for “wear and tear, marring, deterioration.” Normal continual use of fire over time may result in the gradual degradation of some materials which is not covered by any policy. If some specific fire occurs which can be reasonably linked with the development of damage, it is not necessary to determine the hostility of the fire. The sudden and accidental nature of the damage from a non-excluded source is sufficient to bring it within the realm of open perils coverage.

5.3 APPLICATION OF FIRE PERIL TO CHIMNEY FIRE DAMAGE

That a chimney fire is a “fire” should be the subject of little debate. Previous chapters have fully examined the fuel, ignition, behavior, and effects of chimney fires, a summary of which follows:

- A chimney fire involves the combustion of a fuel, usually the accumulated organic by-products of combustion known as creosote, in some part of a venting system.
- Chimney fires are usually ignited by heat, flame, or sparks escaping from an attached appliance, often, but not necessarily, during a period of hotter than normal operation.
- Chimney fires can exhibit obvious signs of occurrence, such as noises, flames, and smoke; but frequently are not so obvious and are not always detected during their occurrence.
- Regardless of the prominence of outward signs, the presence of actual combustion at or near the surface of venting system passageways results in a sudden and significant rise in temperature on interior surfaces.
- Because of the characteristic thermal mass of masonry materials, the temperature on their exterior surfaces does not rise quickly, and a severe temperature gradient is set up through the material.
- Brittle ceramic materials such as clay flue linings are vulnerable to cracking and other damage under the stress resulting from a severe temperature gradient.
- Because of the shape effects of tangential stress on hollow cylinders, a frequent effect of thermal shock from a chimney fire is longitudinal cracks in the flue lining which may remain open or close down to hairline dimensions upon cooling.
- Specific fire conditions or severity may result in other characteristic damage: spalling of the liner surface, additional transverse liner cracks, cracks in the chimney exterior, or ignition or other fire damage to the house structure or attached personal property, etc.
- Chimney fires generally leave behind

characteristic evidence, particularly pyrolyzed creosote with a light, foamy, or flaky nature, as well as peculiar burn patterns within the flue.

It has further been established that chimney fires differ both qualitatively and quantitatively from normal and expected operation of a venting system. The design and materials specifications for standard masonry chimney construction anticipate exposure only to the (non-burning) products of combustion, not combustion itself. The function of various parts of the venting system is defined by their ability to contain and conduct these products and is distinguished from the function of appliances and fire chambers to contain fire. A chimney fire represents an escape of the fire from its intended location and its spreading to an area not intended to contain fire.

Most people then should have little difficulty understanding how a chimney fire is a proper subject of the fire peril. While the source of ignition may have been heat or flames from a fire in a stove or fireplace, a chimney fire itself is not a friendly fire. The original fire may have been intentionally kindled for a friendly purpose, but when it escaped and spread to the venting system it became both a different fire and a fire out of place. The extent or severity of the chimney fire makes no difference. Once it began burning in the venting system, it became a hostile element, and a hostile fire to any degree is covered under the fire peril. Although they are relatively unusual, non-creosote chimney fires, involving flaming in the venting system of fuel-rich gases given off by a fire, also fall within the scope of a hostile fire.

Consequently, any damage that results from a chimney fire is properly covered by any of the common homeowners' insurance policies. This includes damage to the chimney itself, such as cracking or spalling; to any items attached or adjacent to the chimney, such as caps or antennas; or to the building itself in the form of smoke damage or ignition of the structure. Any loss that results from efforts to extinguish the fire, such as water damage, and expenses necessary to protect property from further loss are also included in coverage for such a fire incident. Neither the degree nor type of damage has any bearing on the validity of a claim for damage by a chimney fire. Any damage resulting from a fire is, simply, fire damage whether or not the materials are non-combustible or theoretically “should” have been able to resist the effects of fire.

The court-supported doctrine of “excessiveness” as an element of a hostile fire raises an interesting question about certain modes of appliance operation which could lead to venting system damage. If flames emanating from appliances extend into the venting system and cause damage, the traditional definition of hostile fire is met, and the damage should be covered. It is less clear whether or not a sudden rise in flue gas temperature sufficient to cause thermal shock damage, such as may occur during an incident of overfiring, and would qualify as a hostile fire under a named perils policy. Following the precedents established by cases discussed in FC&S Bulletins,¹¹ it would appear that a fire in excess of appliance design standards would not be considered friendly even if it never actually leaves the appliance. Most of these cases have extended coverage even to the appliance under such circumstances. It would be logical that a venting system which is never intended to contain combustion would be implicitly covered for damage caused by an excessive fire.

The evaluation of both chimney fires and excessive fires is much simpler under an HO-3 open perils policy. Since there is no exclusion with respect to fire, any form of fire which causes specific damage (as opposed to generalized wear and tear) must be covered. Obviously, this includes chimney fires, as under any fire policy, but any other incident (again, not including general routine operation), such as overfiring, which causes damage to the venting system or the appliance itself falls under the scope of the policy.

Therefore, where the occurrence of a chimney fire is known, and the damage caused is identified, there should be no doubt about the applicability of coverage. This is, in fact, the case with the vast majority of chimney fire incidents, and such claims are usually paid without hesitation. However, the unique nature of chimney fires among the various perils traditionally insured against sometimes gives rise to questions and misunderstanding, and a closer look at the criteria for evaluating a claim for chimney fire damage is in order

5.3.1 QUALIFICATIONS OF CLAIM

Establishing the validity of chimney fire claims in general is rather straightforward, but establishing the validity of an individual claim can be more problematic, especially if neither the borrower nor

the insurance adjuster is familiar with the phenomena and characteristic effects of such fires. Chimney fires rarely burn up the house or cause the type of damage usually associated with fires, and they occur in a hidden location, so there is an understandable tendency for some adjusters to view them with some suspicion initially. While some initial skepticism is probably healthy, neither the homeowner nor insurance company benefit from unnecessary or prolonged resistance to valid claims. A means for quickly and equitably settling chimney fire claims is needed.

The root of the problem is that there is not yet a well-developed and consistent set of criteria for validating chimney fire claims as there is for more traditional homeowners’ perils. Several reasons can be cited for this lack of predictability. While information on the nature and effects of chimney fires is abundant, it has not been readily available or widely distributed. As a result, the treatment of chimney fires as an insurable peril has varied considerably from company to company and among adjusters. Evidence available for the individual claim is often not recognized or appreciated. Some companies have relied on the expertise of third-party investigators whose familiarity with the dynamics of chimneys and chimney fires may be no better than the adjuster’s and whose knowledge of the principles of insurance is considerably less. Finally, some companies have attempted to treat chimney fires as somehow different from any other fire and to apply a higher standard of validation than demanded or allowed by the policy.

One of the major purposes of this report is to collect the substantial technical knowledge about chimney fires into a single resource. Chapter 4, in particular, is intended to provide a basis for consistently and accurately diagnosing the cause of various forms of chimney damage. It is hoped, therefore, that the evaluation of the technical evidence for or against a claim for chimney fire damage will be taken to a higher level of accountability. What is left is to examine the application of technical documentation to the decision-making criteria inherent in the policy.

The general qualifications for any insurance claim can be derived from the provisions of the policy:

- An incident must have occurred involving a peril which is among those listed (in a named perils form) and not excluded by the policy;

- There must be a physical loss (such as damage) to property covered by the policy;
- There must be evidence to reasonably link the damage to the peril by direct causation, or, in the case of open perils policies, a lack of evidence to link the damage to an excluded peril.

For most types of loss, especially from fires, this evaluation is relatively easy. Evidence for all three criteria is usually readily available or clearly not present. For fires involving combustible property, the damage itself testifies to the peril. Burned and charred material is an unmistakable sign of a fire. Whether or not anyone was available to witness and actual fire, and regardless of how it was extinguished, the presence of a hostile fire can usually be determined unambiguously. Little time need be wasted speculating about other perils that might have caused damage, and once the possibility of a fraudulent arson has been eliminated, a claim can be processed without delay.

Evidence Of Chimney Fire Occurrence

Developing evidence of damage caused by a chimney fire is not entirely different. While the property involved in the fire (the chimney) does not normally burn (unless the fire spreads to the house), chimney fires do usually leave behind a characteristic residue of pyrolyzed creosote. There is no reason to treat this charred material any differently than the charred remains of any other structure fire. The presence of pyrolyzed creosote is the primary and most distinctive physical evidence that a chimney fire has occurred.

Similarly, just as burn patterns in a building can indicate the origin and progression of a structure fire, so do the post-fire patterns within a flue. Not only do uneven pyrolysis patterns reinforce the evidence of fire occurrence, but they also may provide information on the character and intensity of the fire. Finally, the accounts of any witnesses to the fire are no less credible than those of witnesses to a structure fire. In both case, a description of phenomena associated with each type of fire helps establish the occurrence of fire.

Identification Of Damage

The existence of physical damage to property may be more difficult to detect after a chimney fire than after a traditional structure fire. While damage to the building structure results from

something less than 10 percent of chimney fires, damage to the chimney, in particular to the flue lining, is much more common. Damage to the chimney exterior may be readily discernable, but damage in the flue can be more elusive. Sometimes cracks or spalling occur near the top or bottom of the chimney and can be directly observed. The use of a strong light or reflected sunlight may enable observation deeper in the flue, but often specialized video equipment similar to that used for inspection of sewers and other inaccessible places must be employed. The fact that thermal shock-induced cracks have a tendency to close up upon cooling makes complete detection of damage more difficult. Despite the inherent awkwardness of chimney inspection, a full inventory of actual or possible damage is called for as it is for any fire claim investigation.

Certain patterns of damage are characteristic of a chimney fire. Chief among these is longitudinal cracking of individual sections of flue line. Because of the way thermal stress develops in cylindrical linings, such a pattern is likely to be the first and most widespread form of damage. Secondary transverse cracks are also possible, as is spalling of the inner liner surface. The exterior of the chimney may (or may not) show damage, depending on the details of chimney construction and fire behavior. If present, the most common forms are vertical thermal shock fractures of the chimney wall and a separated bed joint resulting from lifting of the top of the chimney during the fire. These openings may also be accompanied by stains from leaking creosote or steam.

Verifying Cause Of Damage

Producing an unequivocal causal link between the occurrence of a fire and the existence of damage can be the most difficult aspect of evaluating a chimney fire. Unlike the damage exhibited by charred and burned combustibles, the damage cause by chimney fires can be mistaken for damage from other sources, some of which are excluded from coverage. The damage patterns discussed above are consistent with chimney fire causation, but do not by themselves rule out the possibility of damage from another cause. The proper evaluation of the origin of damage requires consideration of the entire body of evidence available. Chapter 4 has been included in this report to aid in the determination of the most probable cause or causes of observed damage and

to help eliminate other less likely causes from consideration.

The establishing of the cause of damage by one means or another is where the evaluation of chimney fire claims most commonly breaks down. Even when the occurrence of a fire and existence of damage is admitted, claims representative frequently continue to resist settlement because of uncertainty about the actual cause of the damage. As a result, the homeowner is sometimes placed in the defensive position of having to “prove” to the satisfaction of the insurance company that a chimney fire caused damage. Since no one was present in the chimney to actually observe the development of damage during a fire, such a proof is rather difficult. The homeowner has only the circumstantial evidence of fire occurrence, in conjunction with damage consistent with a fire, to affirm a theory of causation. Even when such evidence is substantial, it is frequently summarily rejected by the insurer.

Such a situation is improper. It is not strictly necessary that a policyholder prove that a chimney fire or any other peril caused damage to his/her property. To the contrary, it is the responsibility of the insurer to demonstrate otherwise. An insurance policy is a legal document of a type known as a “contract of adhesion.” This is a contract developed unilaterally by one party and offered without opportunity for negotiation to another. Whenever a question of applicability of such a contract arises, the party who drafted the document has the affirmative responsibility to demonstrate that the contract should or should not be enforced. With respect to questions of coverage under an insurance policy, the burden of proof rests with the insurance company. When there exists any ambiguity or uncertainty as to the applicability of coverage, the benefit of the doubt goes to the policyholder.¹³

When this principle is kept in mind the relative responsibilities of the insurer and the insured for producing technical documentation for the validation of a claim become much more focused. The policyholder must be able to supply some persuasive reason to believe that a covered peril could have caused damage to covered property. There should be evidence available that is consistent with this possibility. When faced with the evidence, an insurance company must be able to produce compelling evidence that the supposed

peril could not have caused the damage or that some other force not covered by the policy was clearly responsible for all the damage present. Any remaining ambiguity must be resolved in favor of extending coverage to the policyholder.

As applied to the problem of chimney fires, this means that the policyholder should be prepared to show that a chimney fire is likely to have occurred. The damage present should not be *inconsistent* with the damage that could be caused by such a fire. Such evidence need not be overwhelming. The fact that a covered peril is likely to have occurred and that damage characteristic of that peril is present places the burden of proof on the insurance company to show why the claim should not be honored.

Among all the forces which could conceivably be brought to bear on a chimney, a chimney fire represents one of the more obvious sources of potential damage from both the *nature* and *magnitude* of the stresses which commonly result. Therefore, evidence of chimney fire occurrence, coupled with consistent types of damage, must be considered an extremely powerful argument in favor of a valid claim. Unless a *more* compelling case that *all* the damage present in a chimney was due to some other excluded cause or that some other exclusion reaches the case, it is eminently reasonable to admit coverage under the fire peril.¹⁴

Rules For Evaluation Of Chimney Fire Claims

When the following elements are present a claim for damage from a chimney fire should be deemed reasonably well supported:

- Evidence that a chimney fire or some other fire incident not excluded by the policy occurred;
- Physical damage to covered property consistent with damage known to be caused by chimney fires;
- A lack of clear and compelling evidence that all of the observed damage was the result of some alternative excluded cause.

As with all claims, the insurance company has both a right and a responsibility to fully investigate a claimed loss due to a chimney fire. In many cases the company may retain the service of a chimney sweep, engineer, or other specialist to examine the chimney and to develop evidence

to either support or refute the claim. In evaluating the information and opinions offered by such third parties, the adjuster should keep the evaluation criteria offered above in mind.

Any such reports should realistically consider the evidence available which may support the homeowner's contention that a chimney fire occurred. This, of course, includes the accounts of any witnesses, as well as the physical evidence often present after a fire. The report should also offer a complete inventory of damage present in or around the chimney. Selective concentration on damage patterns not consistent with a fire and exclusion or misrepresentation of consistent patterns are indications of a biased and self-serving report. Responsible investigators will describe damage objectively and completely.

Any alternative explanations offered for the cause of damage should be well-supported and reasonable. It is not sufficient to simply list the things that might cause damage to chimneys in general nor to vaguely speculate about conceivable causes in a particular chimney. Instead, it is necessary to show with reasonable certainty a direct chain of causation from a non-covered peril to the development of the observed damage. Furthermore, in order to support denial of a fire claim, the alternative explanation(s) must account for all the damage observed, not just some. If chimney fire damage is present along with other forms of damage, the fire damage is still the subject of a valid claim and is eligible for repair under the policy. The adjuster may want to consult the review of causes of chimney damage contained in Chapter 4, which is based on engineering principles and expert field experience, for comparison with the evidence offered by the investigator.

Unless another explanation can be reasonably demonstrated, evidence of chimney fire occurrence (a specific and demonstrably efficient potential source of damage) overrides speculative or ambiguous causes of loss. When evidence of fire and fire damage exists, and the investigator is unable to produce a specific and persuasive alternative explanation, chimney fire damage should be accepted by default.

5.3.2 Irrelevant Considerations

Sometimes irrelevant considerations creep into the process of evaluating chimney fire claims. These

are items (which may or may not be facts) that have no bearing on the proper evaluation of a chimney fire claim, but which have been used either explicitly or implicitly to support the denial of a claim. Some of the more common of these red herrings are described below, with commentary. These have been culled both from the direct explanations of company representatives and from reports of third parties being used as the basis for claim denial.

Safety: Prior Or Consequent To A Fire

It has frequently been alleged that cracks in a flue lining do not need to be repaired because the existence of such cracks does not compromise the safety of the chimney. In some cases this has been the sole reason for denial of a claim even when it was admitted that a fire caused the damage. In others, it has been used to suggest that the cause of damage is unimportant because the damage would be considered inconsequential anyway. Some variations on this safety argument include:

- *Flue liners are never gas or moisture-tight; therefore cracks do not increase the likelihood of escape of products of combustion.* (In fact, as documented in Chapter 1, the express purpose of flue lining is containment of the products of combustion. Flue lining should *not* leak, and the presence of cracks materially changes the ability of lining to perform its function. Thus the argument lacks merit on technical grounds, besides being irrelevant for insurance purposes.)
- *The chimney wall surrounding the liner is the part needed to be gas tight: unless it is cracked there is no increase in danger, or need to repair the chimney.* (Again, both a technically unsound contention and irrelevant to the validity of a claim.)
- *Cracks in the flue liner will not result in an increase in the exterior chimney temperature in excess of that allowed by codes and standards.* (Possibly true, though irrelevant. The thermal performance of damaged chimneys has not been studied, so such a contention is, at best, premature. It also ignores the thermal effects of hastened chimney deterioration due to damaged lining.)
- *The local building code does not require that cracked flue liners be repaired or replaced.* (A curious attempt to turn the "ordinance of law"

exclusion on its head and suggest that a loss is covered only if required by law! Anyway, the National Fire Protection Association, NFPA 211 says otherwise.)

- *Damage to a flue liner only need be repaired if actual sections or pieces fall out, leaving an exposed void.* (A damaged house is only covered if a wall falls out?)
- *The chimney is safe to use the way it is.*

As pointed out, most of these contentions are either poorly supported from a technical standpoint or gross oversimplifications of the dynamics of chimney safety. It is likely that damaged flue lining *does* have a significant impact on the safe performance of a chimney, but whether it does or not, any consideration of safety is entirely irrelevant to the validity of an insurance claim. The insurance policy says simply and unambiguously that the insurer will repair or replace property damaged by a covered peril.¹⁴ The only issues pertinent to an evaluation of a fire claim are determination of the occurrence of the peril and the development of damage related to the peril.

If, as a result of windstorm, a tree limb falls against a plate glass window and cracks it, even without dislodging pieces, there is no question that any standard homeowner's policy would fully cover the damage, including the cost of removing and replacing the window. It is inconceivable that a company would deny such a claim on the basis that pieces have not yet fallen out, or that a crack will not allow much air or rain leakage, or that windows sometimes leak air around their edges anyway, or that the local building code does not require replacement of the window, or that the window is "safe." Yet these are exactly the arguments being advanced with respect to cracks in chimney lining, and such arguments are specious.

The policy covers damage from fire unless some exclusion reaches the loss. There is no exclusion in any insurance policy that states or implies that coverage is void if the property is still safe for use after a fire. Advancement of such a concept as basis for denial of a chimney fire claim is utterly without foundation and runs counter not only to the letter, but to the spirit of the insurance contract. A homeowners' policy insures the *property* of the policyholder not his *safety*. When

such covered property is damaged by a covered peril, any consideration of safety is manifestly inappropriate and has no place in any good faith dealings with the policyholder.

Denial of a chimney fire claim on the basis of continued chimney safety places the insurance company in the position of guaranteeing the safety of the homeowner and his property. Were a more serious loss subsequently suffered, the company may find itself liable well beyond the parameters of the original claim.

Degree Of Damage As Determinant

It has sometimes been suggested that, because the extent of damage to the chimney is limited or the size of the cracks is small, the policy need not cover such a minor loss. Damage to the chimney liner has been described as "a cosmetic matter only" or that hairline cracks in liners are common and therefore, inconsequential. Such arguments are similar to the safety issues raised above without the implication that safety is the deciding factor. Instead, it is being suggested that a little bit of damage does not constitute a loss.

While the extent or severity of damage may influence the techniques reasonable and necessary to fully repair the damage, it has no relevance to the determination of coverage. The insurance policy contains no exclusions which suggest that only fire damage of a certain type or extent is covered. It simply provides coverage for "direct...physical loss to property" caused by fire. If covered property has suffered damage from a fire – to any degree whatsoever – that property is eligible for the full coverage extended by the policy.¹⁴

The use of the word "cosmetic" implies (and was asserted directly by one insurer) that damage from a chimney fire is the same as that which may occur during normal use and that the "wear, tear, marring and deterioration" exclusion therefore applies. This suggests that the type of damage can somehow be considered apart from the *cause* of the damage in determining the validity of a claim. This, of course, is without basis since it is the cause itself which is the essential ingredient of any legitimate claim. As pointed out by FC&S Bulletins⁸ in the above discussion of the wear and tear exclusion, kitchen counter tops are subject to deterioration from the rigors of daily life, but if a specific non-excluded event occurs, such as a heavy object falling on and cracking the surface,

such damage is covered regardless of its type or seriousness.

Prior Damage

Another derivative of attempts to misuse the “wear and tear” exclusion is the suggestion that cracks in the flue lining are common. Chimneys are not expected to be in perfect condition. Therefore, since wear and tear can cause cracks, cracks do not need to be repaired because they represent an expected condition of a chimney. Furthermore, it is alleged, since hairline cracks are common, they must have been present before the fire.

Such arguments are technically suspect, logically flawed, and tend to obscure the issues around which a claim should properly turn. It is rather obviously true that chimney liners are not expected to be in their original condition. They will certainly be stained and may have developed cracks from other sources, but it is equally true that houses, in general are not expected to be in their original condition. They may also have suffered a variety of injuries prior to a fire occurrence. If a policy is in force for the dwelling at the time of the loss, it covers the loss regardless of the pre-existing condition. Furthermore, the insurance company is liable for the full replacement cost¹⁵ of the property “without deduction for depreciation.”

If an insurer can prove that there were existing cracks prior to the fire, then those cracks would not be covered, but any other damage that cannot be accounted for by a pre-existing force will still be subject to the full coverage of the policy. If it is possible to repair or replace only the portions of the chimney damaged by the fire, the settlement may be limited to the amount necessary to accomplish this, but the validity of the claim itself is not reduced by the presence of previous damage from whatever source.

Furthermore, “it is up to the insurer to prove that [the cracks] were preexistent; not up to the customer to prove that his current fire caused them.”¹⁴ The mere suggestion that cracks are sometimes found in chimneys in no way reduces the insurance company’s obligation to prove that the specific damage should be excluded and to otherwise cover the full cost of repair or replacement of property damaged by fire.

Severity Of Fire As Measure Of Peril

It has been argued by some field investigators and apparently accepted by some insurance companies that because severe chimney fires can result in cracking of the chimney exterior, unless such cracking is apparent, a chimney fire could not have occurred or been severe enough to cause liner damage. In other words, unless only the most severe of fires occurred, a fire capable of any damage could not have occurred. The insurance company then apparently uses this to contend that an insurable fire could not have caused the observed damage.

Aside from the questionable logic necessary to reach such a conclusion, it is without technical basis. Previous chapters have fully explored the mechanisms of liner damage, and it should be clear that the magnitude of stress developed in the liner during any chimney fire is much greater than in the chimney wall. While very severe fires can also develop failure stress in the wall, the likelihood of liner failure is far greater. The population of chimney fires which damage the chimney wall is a small subset of the much larger population of fires which damage only the liner.

From an insurance standpoint, such a basis for claim denial is little more than a disguised version of the friendly fire argument. It is simply an attempt to suggest that a fire severe enough to “only” damage the liner could not have been a hostile fire. There is no basis for such a contention. Equivalent logic would suggest that, since tornados can completely destroy houses, a house which merely lost its roof could not have been damaged by a windstorm. It is doubtful that any insurance company would stand on such a contention, nor should they for chimney fires.

The only measure of a peril is its occurrence. If there is evidence that a chimney fire occurred, then a force known to be capable of damage is likely to have been present. Unless all the observed damage can be positively associated with a different cause, acceptance of the chimney fire claim is both logical and reasonable.

Latent Defect; Faulty Installation

Several insurance companies have attempted to argue that cracking of clay flue lining during a chimney fire is an indication of a latent defect or

that improper chimney construction or installation of the lining caused or contributed to the loss. These are appeals, respectively, to the “inherent vice, latent defect, mechanical breakdown” exception found in the Perils Insured Against section of the HO-3 policy and to the “faulty, inadequate, or defective...design, ..workmanship, repair, construction” language in the Section I Exclusions for the same policy. Both are irrelevant to the vast majority of claims.

As has been emphasized in this report, vitreous clay flue lining is a brittle ceramic material which has many advantages but which is susceptible to thermal shock fracture during the abnormal conditions of a chimney fire. Cracking of a flue liner during a chimney fire is no more indicative of a latent defect than is the burning of a wooden wall during a building fire. Neither is intended for exposure to fire and both can be expected to fail if subjected to conditions outside their intended use.

Furthermore, the policy disclaims coverage only for correction of the latent defect itself and clearly states that any ensuing damage is covered. If the homeowner were, for instance, to discover a cracked defective tile prior to a fire, an insurance claim would not be proper. If a tile cracks as a result of a fire (even if it can be shown that it was defective), a claim would be valid. The key element of a claim is the occurrence of a covered peril, not the previous perfection of the damaged property.

Similarly, the faulty or inadequate construction exclusion applies only against claims to repair the defect itself or in cases where the poor construction contributes to a loss concurrently with another excluded peril.¹⁶ Regardless of whether or not the chimney or its lining was properly constructed, any damage caused to it directly by a covered peril, such as a fire, is unequivocally covered. Furthermore, this exclusion just as clearly states that ensuing damage is covered. Even if the poorly constructed chimney were to cause a fire, any resulting damage falls fully within the scope of the policy.

Both of these exclusions have little if any application to chimney fires. Unless it can be shown that all of the damage to the chimney was solely due to inherent defects or faulty workmanship and not in any way caused by fire, neither exclusion applies. In the face of evidence

of chimney fire occurrence, such a contention would be very difficult to support.

Lack Of Maintenance By The Insured

It has been pointed out that the homeowner’s failure to clean the chimney provided the fuel for a chimney fire. Although no cases are available of a claim being denied outright for this reason, it has been suggested on more than one occasion that the homeowner’s lack of maintenance was a factor contributing to the damage. The implication is that the insurance company’s obligation to cover the loss is somehow reduced.

There are only two reasons that an insurer can deny or reduce fire coverage based on a homeowner’s action or failure to act. The first is if the insurer can prove that the policyholder deliberately set the fire for the purpose of causing a loss. The second is where the homeowner fails to take reasonable steps to protect property from further loss after the occurrence of a fire. Even in that case, only coverage for the additional damage can be denied. The original damage caused directly by the peril is still covered.

The existence of a fire hazard prior to a fire is an underwriting problem, not a claims problem. Unless the insurance company detects the existence of unsuitable conditions during the discovery period, the acceptable reasons for cancelling a policy or denying coverage become extremely limited.¹⁴ Some companies have developed programs to provide incentives for homeowners to have their chimneys swept and thereby reduce the likelihood of a severe fire, and such efforts are laudable, but an insurance company may not retroactively apply an underwriting criterion after a loss has occurred.

It might be pointed out that the Section I Exclusions for the HO-3 policy contain an exclusion for “faulty, inadequate or defective...maintenance” or that allowing the development of creosote in a chimney would amount to an “increase in hazard” excluded by the Standard Fire policy. Neither argument is close to being persuasive. For faulty construction, the maintenance exclusion applies to losses caused only by that problem. The insurance company should not pay to sweep the chimney before a fire, but if the accumulated material catches fire, the resulting loss is caused by fire not lack of maintenance. The increase in hazard provision applies to the introduction of a major new hazard

by the insured, not the gradual accumulation of material that might burn. In other words, converting a garage to a fireworks warehouse is an excludable increase in hazard. Allowing a normal amount of half-used paint cans to accumulate is not a basis for denial of coverage nor is allowing creosote to accumulate in a chimney.

In summary, the relatively new and unique problem of damage caused by chimney fires has given rise to some misunderstanding about the applicability of coverage. Insurers must not allow issues which are not relevant to fire coverage to sully the claims process. Since third-party investigators may not be well-versed in the principles of insurance, adjusters should be wary of and ready to reject any such specious arguments. Instead, only the central issues to the validity of a claim – the occurrence of fire, the existence of damage, and the availability of proof of non-covered causation – should enter into consideration. Adherence to these rules will result in fair and expeditious claims adjustment and avoidance of unnecessary public relations problems.

NOTES

1. *Fire, Casualty & Surety Bulletins*, The National Underwriter Company, Cincinnati, OH, updated periodically. The FC&S series, which consists of several volumes, is used as a general reference for most of the following. Where appropriate, specific references will be made to FC&S, with the particular volume or page indicated.
2. *FC&S, Fire & Marine Volume, Miscellaneous Property A- to Ae-*, September, 1989.
3. *FC&S, Fire & Marine Volume, Miscellaneous Property Exa-*, June, 1990.
4. *FC&S, Personal Lines Volume, Dwellings H-*, April, 1990.
5. *FC&S, Personal Lines Volume, Dwellings Ha-*, April, 1990.
6. *FC&S, Personal Lines Volume, Dwellings Hob-*, August, 1988.
7. *FC&S, Personal Lines Volume, Dwellings Hob-*, August, 1988.
8. *FC&S, Personal Lines Volume, Dwellings Hob-2*, August, 1988.
9. HO-2 Ed. 4-84, Insurance Service Office, Inc., 1984 (HO-3 same).
10. *FC&S, Fire & Marine Volume, Misc. Property Ad-*, October, 1989.
11. *FC&S, Fire & Marine Volume, Misc. Property Ba-*, October, 1989.
12. *FC&S, Fire & Marine Volume, Misc. Property Ba-4*, October, 1989.
13. David L. Bickelhaupt, *General Insurance*, Richard D. Irwin, Inc., Homewood, IL, 1983.
14. Michael McCracken, Assistant Editor, *FC&S Bulletins*, National Underwriter Company, Cincinnati, OH, personal communication, January, 1992.
15. *FC&S, Personal Lines Volume, Q & A 720*, April, 1990.
16. *FC&S, Personal Lines Volume, Hob-6,7*, August, 1988.